

BROADCAST NEWS

 *Color Television*

COLOR TELEVISION



ISSUE



Number 77

Jan.-Feb. 1954

PRICE

In continental U.S.A. --- \$4.00 for 12 issues

In other countries ----- \$5.00 for 12 issues

BROADCAST NEWS

PUBLISHED BY THE RADIO CORPORATION OF AMERICA
ENGINEERING PRODUCTS DIVISION • CAMDEN, NEW JERSEY



CONTENTS

ABOUT THIS ISSUE OF BROADCAST NEWS	2
COLOR TELEVISION—WHAT IT MEANS	
TO THE BROADCASTER <i>by J. H. Roe</i>	4
RCA COLOR TELEVISION SYSTEM <i>by J. H. Wentworth</i>	6
HOW TO PLAN FOR COLOR <i>by L. E. Anderson</i>	20
TELEVISION TRANSMITTER OPERATION	
WITH COLOR SIGNALS <i>by T. M. Gluyas and N. J. Oman</i>	34
VIDEO AMPLIFIERS IN COLOR SIGNAL	
TRANSMISSION <i>by A. H. Lind</i>	44
THE RCA COLORPLEXER <i>by J. H. Wentworth</i>	48
RCA COLOR SYNC GENERATOR EQUIPMENT <i>by A. H. Lind</i>	50
RCA COLOR SLIDE CAMERA, TK-4A	
<i>by W. E. Tucker and F. J. Janda</i>	52
RCA COLOR FILM CAMERA, TK-25A <i>by W. J. Poch</i>	58
RCA COLOR CAMERA, TK-40A <i>by F. W. Millspaugh</i>	62
RCA COLOR TV MONITOR, TM-10A <i>by A. H. Lind</i>	72
TEST EQUIPMENT FOR COLOR TELEVISION <i>by J. A. Bauer</i>	76

“RCA PIONEERED AND DEVELOPED COMPATIBLE COLOR TELEVISION”

Copyright 1954, Radio Corporation of America, Engineering Products Division, Camden, N.J.

TMK. ® PRINTED IN U.S.A.

About This Issue of BROADCAST NEWS

Most readers of BROADCAST NEWS are familiar with its motives and methods. But this is a very special issue. And it will be read, in all likelihood, by many who are not so well-acquainted with us. It seems fitting, therefore, that we begin with a brief explanation of the reasons for this special issue. Also, perhaps, a little about the scope of the material included and some suggestions for using it.

Why a Special Issue on Color

This is the first time (in twenty-two years) that a complete issue of BROADCAST NEWS has been devoted to a single subject. And it is the first time (except for one minor reference) that color television has been mentioned in its pages. These two facts are somewhat related.

BROADCAST NEWS, as its older readers know, is devoted exclusively to broadcast station engineering and operation. It is primarily intended to help the station engineer in his everyday job. Because of this emphasis on practical operation BROADCAST NEWS has seldom delved into the future. And, until now, color television has been "in the future" for most broadcasters.

Overnight—although hardly without warning—all of this is changed. The FCC has approved Color television standards based on the RCA compatible all-electronic system. This action makes color television an immediate reality. That changes our viewpoint—and the viewpoint of every station operator.

Certainly every present and prospective TV station will at least pause to consider the implications of C-day. Most stations will want to make some plans, even though they be long-range plans. To do so they will need to know what equipment and facilities are needed for color. And they will need to know not in generalities, but in specific terms. That's where this issue of BROADCAST NEWS fits in.

For some time the editorial staff has been working with our television engineering group to prepare a series of articles on

color television station equipment. Our original intent was to publish these articles one or two at a time over a period of months (interleaving them with our regular material). However, it is now evident that stations need all of this information, immediately. That is why we have decided to print it all in this one big exclusive color issue.

This will pretty much catch us up on color, and to some degree get it out of our system. Moreover, it has the advantage that those who are absolutely uninterested in color (breathes there the man with soul so dead?) can simply toss this whole issue in the ash-can and look forward to the next issue. And we promise that color, although there will continue to be many articles on it, will not again push out other things completely. There will still be plenty of articles on audio, AM, monochrome—yes, even FM. So help us!

Who Is This Issue Written For

We know that station managers and owners (as well as engineers) read BROADCAST NEWS. And we want to give them some things they can enjoy without dusting off their calculus. Therefore, in most issues we purposely include a number of relatively non-technical articles. And, wherever possible, we use lots of pictures so that even those who do not read the articles will find "the story in pictures".

We would have preferred to follow that policy in this issue. But to make the kind of material we have in this issue even relatively "non-technical" would have destroyed much of its value for the station engineer. Debating this dilemma we decided that the station engineers' need was greatest. He is the first one in the station who will come to grips with color. He is the one who will have to answer the station owner's question, "What should *we* do about color?" And, to answer, he needs to know a lot about the equipment. To give him maximum help we have had to go strong on the technical side. We hope the station managers will pardon us this once.

Where Does It Start

We had a similar problem as to where to start our writeup of color television equipment. Television broadcasting, even in monochrome, is rather complex. To start from scratch and explain the whole TV system would have required several times as much space as we had available. Or, alternatively, we would have had to dilute the whole story. Faced with this situation we decided, again, to keep the information concentrated and thereby favor the men who need it most. This meant, very simply, starting with the assumption that the reader is familiar with the technical operation of the present black and white television system. Engineers and operators of existing TV stations have such a background. So do most AM engineers who have followed the development of TV to date. Those readers who do not can find the necessary background information in several available books.*

What Subjects Does It Cover

With respect to the range of material to be covered we also had a problem. The advent of color television raises many questions. To begin with there are the basic questions such as "what is color?" and "how do we perceive color?" After these have been answered there are questions on programming, on production, on operation, on transmission and on reception. All are of some interest to the station engineer. But the one he is most interested in, and will have to solve first, is that of the transmission of color.

There have already been numerous general articles on color television, and there will surely be many more, both in popular and technical magazines. We may assume that these will serve to answer the general questions on color. It is also likely that there will be many articles on color TV

* Two recent books on TV station operation are:

1. "Television Broadcasting," by Howard Chinn, published by McGraw-Hill Book Co., 330 W. 42nd St., N. Y. C. 36.
2. "Principles and Practices of Telecasting Operations," by Harold E. Ennes, published by Howard W. Sams & Co., Inc., Indianapolis, Indiana.

reception. The fact that most segments of the industry—set manufacturers, distributors, dealers and service men—are primarily interested in receivers guarantees this. We decided, therefore, that we would not make any attempt to cover in BROADCAST NEWS either the basic concepts of color TV, or those aspects of color which concern reception, receiving antennas, receiver design or receiver operation. These we will leave for others, while we concentrate on the problems of producing and transmitting color pictures.

It is in this area of *color transmission* that there is likely to be the least immediately available information. And it is this very information which the station engineer is most interested in. Fortunately, this is an area in which we speak with authority. By far the greatest amount of practical work (as distinguished from paperwork) on compatible color transmission—almost all of it, really—has been done by RCA and NBC engineers. RCA is the only company which has a full line of color equipment designed *and in production*. Thus it seems fairly certain that most of the color broadcast equipment installed in the near future will be RCA. And no one, but no one, can furnish better information on that than we can.

What Type of Equipment Is Described

The color TV equipment which is described in this issue of BROADCAST NEWS is the equipment which the Engineering Products Department of RCA is presently manufacturing in its plant at Camden, N. J. (As of January 15, 1954, complete color networking equipment had been shipped to twenty-six stations of whom twenty carried the color telecast of the Tournament of Roses Parade on January 1, 1954. Some fifty additional stations are scheduled to receive this equipment within the next three months. Shipments of color studio cameras will start in February, 1954). This equipment is patterned after, and is quite similar to the equipment which was used by RCA in the most recent demonstrations for the FCC and which is the equipment that is referred to in Par. 23 of the FCC's "Report and Order" on Color Television (December 17, 1953). A full four-camera setup of this equipment is installed in NBC's Colonial Theatre Studio where it has given very satisfactory operation for the past year. Additional cameras have been in use in RCA's laboratory studio at Camden. Their operation has been witnessed by hundreds of engineers, including those from consulting firms as well as

networks and stations. There is no question, therefore, about the performance of this equipment. Its satisfactory operation has been proved over and over again.

It should be noted that in the design of this equipment the prime requirement was that it provide the best possible color picture. No compromise of quality was allowed either to reduce the size or the cost. As a result this equipment is large—and fairly expensive—by black and white standards. It is probable that when it is redesigned various simplifications will be introduced which will considerably reduce the overall space requirements. Work along these lines is already underway in our engineering department. However, it is likely to be two years or more before the fruits of this work become available in the form of finished equipment. In the meantime stations can install equipment of the present design with full confidence in its proved performance—and with full knowledge that newer designs, when they come, will not make this equipment obsolete from the quality standpoint.

How Is the Material Arranged

The material in this issue is arranged in the order it would be read by a cover-to-cover reader. It starts with a short introductory, "Color TV—What It Means to the Broadcaster." This short article is intended to set the background for the technical articles which follow.

The specific equipment articles are preceded by two general articles. The first describes the principles of the system and in particular explains the "colorplexing" idea. A basic understanding of this principle is necessary in order to understand the operation of much of the equipment. Putting the material in a general article saves repetition in the equipment articles.

The second general article is entitled "How to Plan for Color TV." It describes in a general way (and gives a detailed list of) the equipment needed for various types of operation. In other words, it tells how to put the equipment units together. The "stages" of equipment installation outlined are those referred to in Par. 23 of the FCC decision on color television (December 17, 1953).

Following the general articles is a series of equipment articles written by members of our TV engineering groups (with a certain amount of assistance from the editors). In general, each author has covered the equipment, or subject, on which he personally has been working. Thus it is no

exaggeration to say that every article is written by the topmost authority on that particular subject.

There are nine of these equipment articles—each describing an integrated equipment grouping, such as a camera chain, or a logical association of equipment units, such as "test equipment". These articles are intended to be complete in themselves; however, considerable cross referencing has been used in order not to repeat descriptions of common functions. Those who read from front to back of the issue will find these cross references in reasonable order.

How to Use This Material

As previously noted, the material in this issue is arranged in logical order for cover-to-cover reading. In general, the several types of equipment are considered in the order that they might be added as the station's color facilities grow. Readers may find the following suggestions helpful in using this issue.

(a) *Station Engineers* should begin by thoroughly digesting the article on the system. It is not necessary, at least at first, to remember all the details. However, a good comprehension of the colorplexing idea and of the function of the chrominance sub-carrier is absolutely necessary in understanding the operation of the equipment units. Next, the engineer should study the "How to Plan" series in order to get the feel of a color equipment installation. Finally, he should study carefully each of the equipment units (or, at least, those which will be needed in his installation). After, and only after, he has done all this he should carefully consider the detailed lists of equipment to determine exactly what he needs to fit his particular operation.

(b) *Station Managers and Owners* who do not have a technical background will probably not be able to wade through all of the above procedure. We suggest that they start by reading one of the more simplified introductions to color (such as the brochure "RCA Color Television" published by the RCA Department of Information). Following this they should turn to the "How to Plan" article and skim through it to get the general idea of the equipment involved. They may then wish to "thumb through" the equipment articles and study the pictures in order to have the feel of the equipment. After they have done this they will be in a position to sit down with their station engineer and start talking about a color installation.

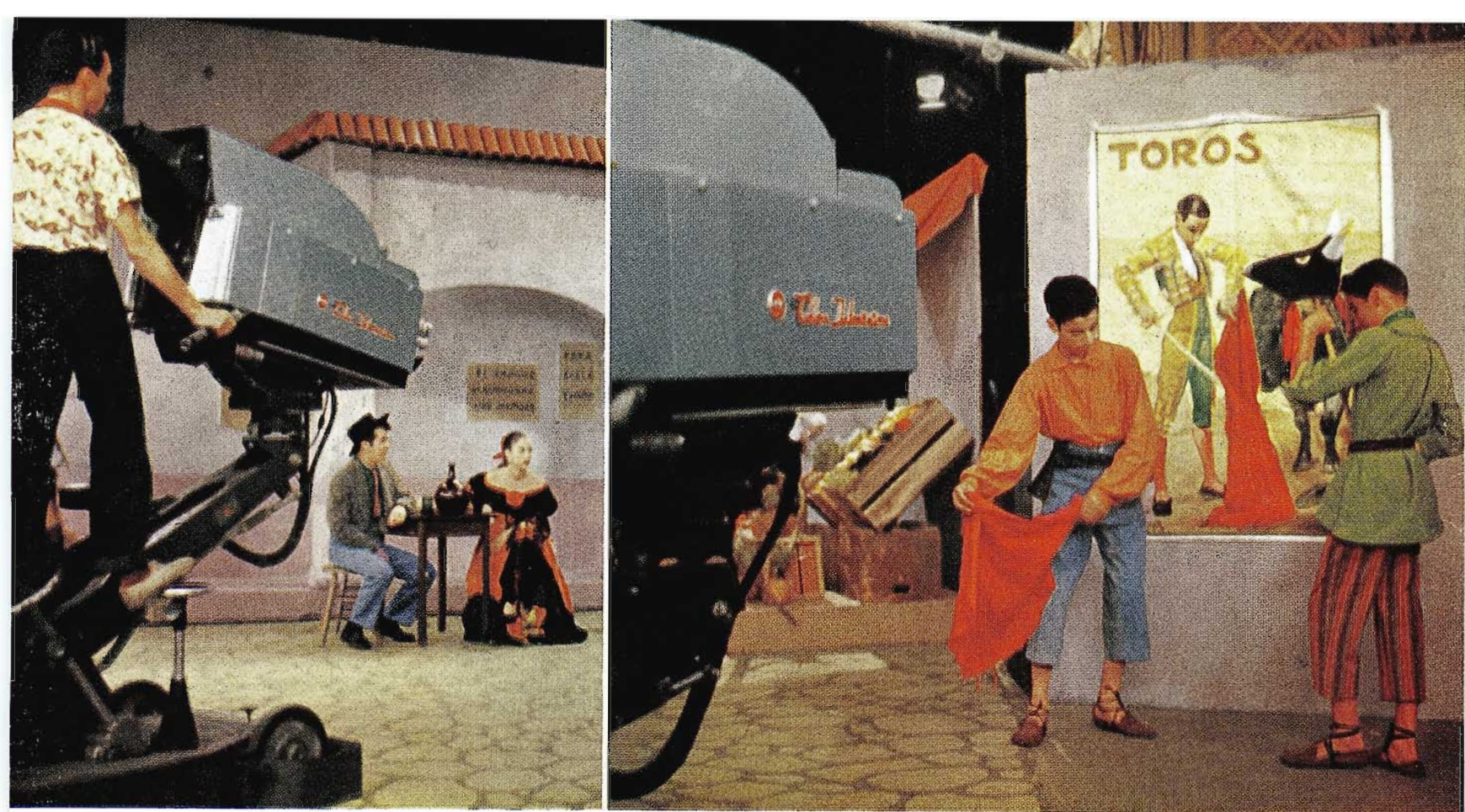

COLOR TELEVISION

WHAT IT MEANS TO THE BROADCASTER

By

J. H. ROE

Manager, TV Camera Equipment Group

Color television will be a boon to broadcasters. It will supply something the public wants and demands. Rendering good service or supplying a good product where a ready market exists benefits both the buyer and supplier, and that is good business. If anything can increase the consumer's desire for the product, such as an improvement in quality or an expansion of service, that too benefits both parties. Obviously success is dependent on being able to make the product to sell at a price the consumer is willing to pay. If the cost is high, the product desirability must be high in order to sell successfully. Where does color television fit into this picture?

In the post-war development of black-and-white television broadcasting, 108 VHF stations were built before the authorization of additional stations was halted by the "freeze." Nearly all of these started in the "red", many deeply in the "red", and many stayed there for long periods of time. Today, however, most of these stations are still in existence, and there is very little doubt that they are good, paying businesses. With the lifting of the "freeze", many more are getting started, and there have been few failures. The reason is that television has become a wonderful medium

for communication. The public likes it because it brings a wealth of information and entertainment. Advertisers like it because a message without an equal in effectiveness is delivered right into people's homes.

Color television is a new dimension in broadcasting. It adds the opportunity for broad expansion in the amount of information and entertainment sent to millions of viewers. Color television likewise has a great attraction for the advertiser who sponsors the programs. Even with the little experience he has had with color, he is fairly drooling at the prospect of being able to show his products just as they really look. Color will cost more, but not prohibitively more. It will provide increased information which the public will buy.

How Does Color Telecasting Differ from Black-and-White?

Basically it doesn't differ at all. The video signal generated in the cameras contains more information than in the monochrome system. It is sent out over the same transmitter, with minor modifications

and additions, as for black-and-white. It can be received on any present black-and-white receiver and produce a satisfactory black-and-white picture. This is the beauty of the compatible color television system developed by RCA. In a color receiver, a color picture is produced. If a color receiver picks up a signal from a black-and-white station, it reproduces that picture in black-and-white.

What is the difference in the video signal necessitated by the addition of color information? To begin with, a black-and-white signal contains just one kind of information—brightness. It provides a continuous story about variations in brightness (lights and shadows) in various parts of the scene. The color video signal must contain exactly this *same information*, and, *in addition*, it must contain information about two other quantities, called hue and saturation, which describe the characteristics of color in the scene. Hue is another word for color, such as red, blue, orange, etc. Saturation describes the intensity of the color; for example pastel blue is much less saturated than a so-called dark blue. Yet, there may be differences in brightness in either case. In a particular scene, there may be a dark blue area in the shadow

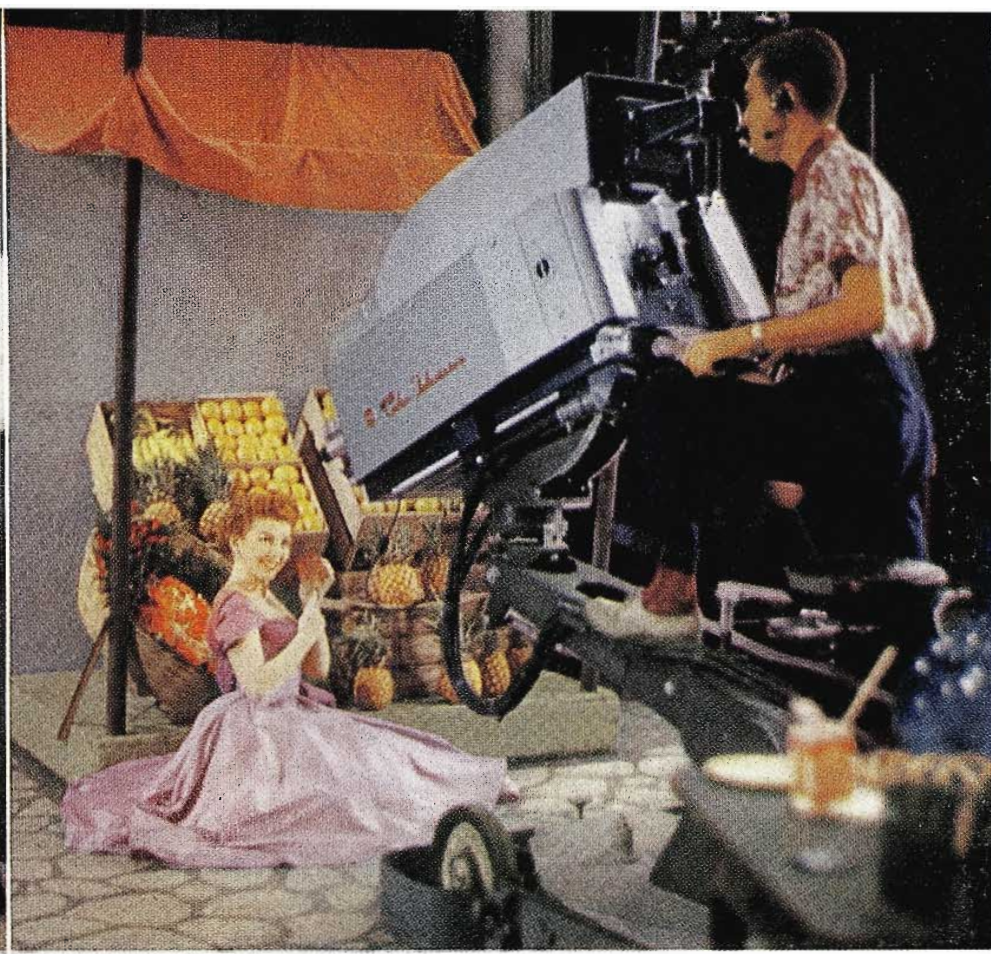

which lacks much brightness, while a pastel blue area may be very bright indeed.

It happens that brightness information in either a black-and-white or a color picture does not fill all the video spectrum of about 4.5 megacycles. There are frequent gaps which contain no essential information in the case of the black-and-white signal. It is in these gaps that information about hue and saturation is added to form the complete color signal. Thus it is not necessary to expand the limits of the video band to accommodate the extra color information. An explanation of how color is inserted in these gaps is found in another article in this issue.

Is Different Equipment Needed to Handle Color Signals?

A modest amount of new equipment (dependent upon the scope of operation) will be required to handle Color TV programming. For a complete discussion of this subject see "How to Plan for Color", by L. E. Anderson. No large investment is needed to enable you to handle color network signals adequately.

Are Different Operating Techniques Required?

Basically, no. The general arrangement of operating positions and controls is much the same as for black-and-white. Some special features to which program people and technicians have become accustomed will be available for color. Some of the more modern features for increasing flexibility

and special effects will take time for more extensive development before they are feasible for color. However, no serious fundamental difficulties are evident which would prevent the full utilization of modern programming techniques. In programming, there is no doubt that more light is required for color by a factor of about two to one. Costuming and stage sets, however, will cost no more except in cases where unusual color effects are required.

Is More Skill Required of Personnel?

Functions performed by camera men, technical directors (switching), program directors, and master control operators can be performed in the color system by people of the same occupational skill as for black-and-white. The same is very largely true for video control operators and transmitter operators, but in these cases there will be need for acquiring direct knowledge in the additional functions to be performed.

The category of test and maintenance people requires a higher level of skill. Routine maintenance of equipment will require more knowledge, more skill, more patience, and more time. In many cases this may require only more extensive training of people already on the station staff, but in others it may require new people of better training.

The total number of people required may be somewhat larger, but the increase will be mostly in the maintenance staff and probably not in the actual operating crew,

General Comments

Is color mysterious or complex? Emphatically no! It is an outgrowth of the black-and-white system, and while it does more things and has more circuits and controls, it is based on the same principles. To many, the language and the symbols of colorimetry and the multiplexing of video signals with sub-carriers will be new, but they are not fundamentally difficult, and can be readily understood by the average technician who is reasonably skilled in his job. It is more complex than the black-and-white system since the system must handle more information. Even in the present early stage of development, it has been found to be not too complex to operate successfully on a day-in, day-out basis.

Does it have good quality? Definitely yes! Recent broadcasts in New York received good reactions from the public, the press and the advertising people. Observation on monochrome receivers, in the absence of color, makes possible a critical evaluation of many characteristics which might be partially blanketed by the presence of color.

Where does a broadcaster start with color? RCA has engineered several station plans for starting with color. A complete description of these plans is given in a subsequent article in this issue, "How to Plan for Color TV." This and more information of value will be found in the group of articles included in this issue of BROADCAST NEWS.



RCA COLOR TELEVISION SYSTEM

Requirements for Compatible
Color Television Systems

By

JOHN W. WENTWORTH
Supervisor, TV Terminal Equipment
Engineering Group

The word *television* literally means "vision at a distance." We like to think of a television screen as a "window" through which a televiewer can watch a scene that may be taking place many miles away. Let us face the fact that television engineers and broadcasters are in the business of creating illusions. What we actually create on the kinescope in a televiewer's home is a constantly changing pattern of light generated by a tiny flying spot, but we can make this pattern of light stimulate the eye and nervous system of the televiewer in such a way that he gets the *illusion* of actually witnessing a scene taking place before the television camera. Naturally, we would like to make this illusion as convincing as possible so as to put a minimum strain on the televiewer's imagination.

Color television is more appealing than black-and-white television mainly because it is capable of producing more convincing illusions. Normal vision for the vast majority of human beings is *color* vision, so any picture-producing process that does not include color puts more of a strain on the observer's imagination than does one that includes color. Fortunately, the eye and the brain are sometimes easy to satisfy in these respects. We have built up a very impressive television industry by producing pictures in black-and-white only. While images

that show green grass, blue skies, and red lips all in the same monotonous shade of gray usually succeed in giving the televiewer the desired perceptions, they would be much more effective if presented in full color. In fact, there are many types of subjects (notably outdoor scenic views) which are very uninteresting in black-and-white but which have real aesthetic value when presented in color.

When we study the problem of developing a color television system suitable for a broadcasting service, we quickly discover that we cannot confine our attention to technical factors alone. To determine the suitability of any particular color television system we must consider not only the technical requirements (Does it produce high quality pictures?) but also the factors of Government regulations (Does it satisfy FCC requirements?), economics (Does it permit mass produced receivers, and does it permit the broadcaster to initiate a color broadcasting service without great financial risk?), public interest (Does it in any way detract from the value of an existing broadcast service?), and conservation of resources (Does it make the most effective possible use of the frequency spectrum?).

After examining all of the pertinent factors, we may establish a list of minimum requirements for a broadcast color television system. The writer feels that the following list is supported by the vast majority of engineers in the industry.

(1) *The Colorimetric Requirement*: The system should be capable of producing high-quality images with good color fidelity. Performance with respect to flicker, brightness, contrast, resolution and picture texture should be substantially equal to that provided by the present black-and-white standards.

(2) *The Compatibility Requirement*: The signal produced by the color television system should be capable of producing high-quality images on existing black-and-white receivers without requiring receiver modifications of any sort. Conversely, the color receivers designed for the color system should be capable of producing black-and-white images from black-and-white broadcast signals.

(3) *The Channel Utilization Requirement*: The system must be capable of operating within a 6-megacycle broadcast channel, in order to satisfy the FCC ruling to this effect. In addition, the system should make the most effective possible use of the frequency spectrum by assigning the available spectrum space to the various components of the color signal in proportion to the eye's demand for the information conveyed by those components.

In 1949, the Radio Corporation of America announced the development of a color television system which it felt provided a satisfactory framework for a broadcast service. Since 1950, RCA engineers have collaborated with the engineers of many other companies through the medium of the National Television System Committee to work out a set of signal specifications which result in optimum performance within the broad framework of the original RCA system. These signal specifications, in final form, were submitted to the FCC for approval on July 23, 1953 and they were approved on December 17, 1953. This paper describes the principles of operation of the RCA color system, and presents explanations for the exact signal specifications approved by the FCC, under which the system meets the basic requirements listed earlier.

Elementary Colorimetric Principles

Color vision for the great majority of human beings has three more or less independent attributes—these are: brightness, hue and saturation. *Brightness* is most clearly explained to television engineers by stating that it is the only characteristic of colors that is transmitted by an ordinary black-and-white television system; brightness is that characteristic by means of which colors may be located in a scale ranging from black (darkness) to maximum white. *Hue* is that characteristic by means of which colors may be placed in categories such as red, green, yellow, blue, etc. *Saturation* refers to the degree by which a color departs from a gray or neutral of the same brightness; pale or pastel colors are much less saturated than those that are “deep” or vivid.

It should be apparent at this point that one of the problems involved in converting a monochrome television system to a color television system is the problem of handling additional information. Instead of controlling the single variable, brightness, we must control three independent variables—brightness, hue, and saturation. To do this, we must provide no fewer than three independent signals, and they must be of such a nature that they can be produced by physically-realizable pick-up tubes and utilized by physically-realizable reproducing devices. To show how these colorimetric requirements can be met by a practical color television system, let us consider briefly the relationships between color sensations and the light energy that constitutes the physical stimulus.

It is a matter of common knowledge that there is a strong similarity between light and radio waves. We designate as *light* those electromagnetic waves to which the

human eye is sensitive, extending over a wavelength range of roughly 400 to 700 millimicrons (a millimicron is one-billionth of a meter). The response of the eye is not uniform over this region, but follows a response curve shaped very much like a probability function and peaked at 555 millimicrons, as shown in Fig. 1. This curve describes the spectral characteristics of the *brightness* sensation only, and indicates that a given amount of energy may appear much brighter at some wavelengths than at others. Response curves vary somewhat from person to person, but Fig. 1 shows the specific curve representing the average response of a great many observers and adopted by the International Commission on Illumination in 1931 as the standard *luminosity function* or visibility curve.

The other two variables of color—hue and saturation—are controlled by the relative spectral distribution of light energy. To a first degree of approximation, hue is determined by *dominant wavelength*. In fact, the various wavelength regions of the visible spectrum are commonly designated by specific hue names, ranging from violet and blue for the very shortest wavelengths through cyan (or blue-green), green, yellow, and orange to red for the longest wavelengths. These major hue regions are designated roughly on Fig. 1. Saturation is determined by *radiant purity*, or the extent to which the light energy is confined to a single wavelength or a very narrow band of wavelengths.

Fig. 2 should serve to illustrate how hue and saturation are controlled by the spectral distribution of light energy. If the radiant energy from a color is spread out more or less uniformly over the visible spectrum, as shown at A, it is generally perceived as white (or gray, depending upon the relative brightness). If the distribution curve has a slight hump or peak, the color is perceived as a pale or pastel shade of the hue corresponding approximately to the dominant wavelength. For example, a color with a distribution curve corresponding to curve B would be perceived as a pale yellow. If the distribution curve consists of a fairly sharp peak around the same dominant wavelength, as shown in curve C, the color generally has the same hue but is more highly saturated. Maximum saturation occurs when the spectral distribution curve is a single line, corresponding to single-wavelength radiation.

Psychologists and physiologists are still searching for a completely satisfactory explanation as to *how* human beings are able to perceive colors. The most promising theory of color vision is based on the assumption that there must be three kinds of

cone cells in the human retina with overlapping spectral sensitivity curves but with peaks occurring in roughly the red, green, and blue portions of the spectrum. According to this theory, the brightness sensation is controlled by the sum of the responses of the three types of cells, while hue and saturation are determined by the ratios of stimulation. Fortunately, we do not need a complete understanding of all the intricate processes involved in human vision in order to develop a color-reproducing process, because we may employ the *primary color concept*, which has been verified (though not completely explained) by a great body of experimental data.

It is an experimentally proved characteristic of human vision that nearly all of the colors encountered in everyday life can be matched by mixtures of no more than three *primary* colors. Consequently, it is possible to produce full-color images of complete scenes by superimposing three primary color images; this basic process is used by nearly all modern color-reproducing systems, including color photography and color television. Contrary to popular belief, there is no one set of colors with “sacred” properties that make them *the* primary colors—any set of three will do, provided only that no combination of any two is capable of matching the third. It so happens that the most *useful* set for color television purposes (i.e., the set with which it is possible to match the greatest range of everyday colors) consists of highly-saturated red, green, and blue. The FCC signal specifications use standard colorimetric designations to describe the specific set of red, green and blue primaries recommended for color television.

The colorimetric principles used in color television are illustrated by Fig. 3. At the receiving end of the system, a full-color image is produced by adding the light output of three registered images in red, green and blue. There are three basic methods for combining the primary images: (a) Superposition by means of dichroic mirrors or by projection to a common viewing screen, (b) rapid sequential presentation at a rate fast enough to cause addition by the “persistence of vision” effect, or (c) presentation of the images in the form of intermingled primary color dots or other elements too small to be resolved separately.

Since the final color picture involves three variables, the color camera must provide three independent video signals. To accomplish this, the camera must have, in effect, three independent pick-up or transducing elements. In some color cameras, three entirely separate pick-up tubes are

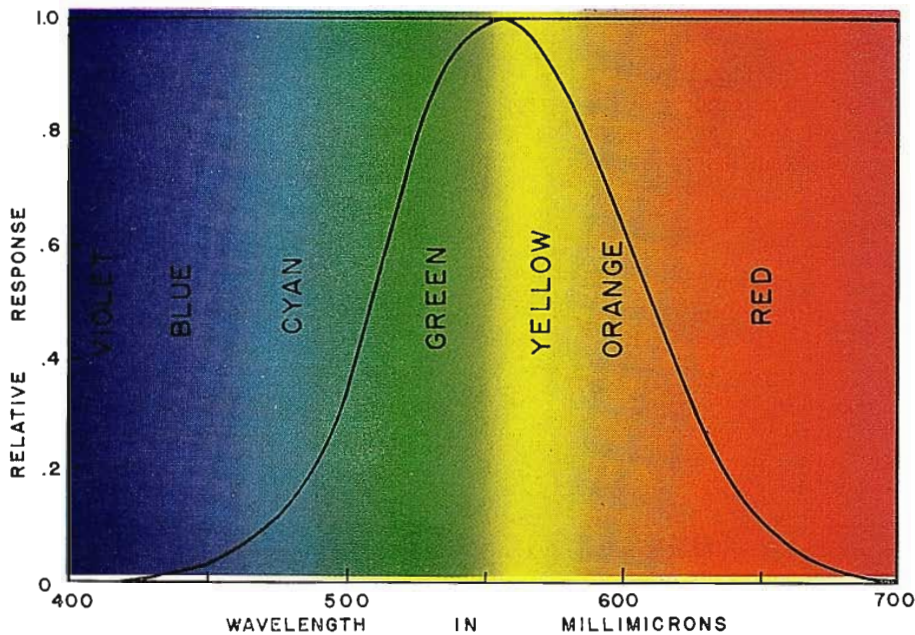

FIG. 1. Chart of the visible spectrum, showing the major hue regions.

used in conjunction with an image-dividing optical system, but it is also possible to combine the three sets of transducing elements in a single tube envelope or to use a single tube in three different modes of operation (by means of rotating optical filters). The simplest type of color camera from an analytical point of view is one in which three pick-up tubes are used to provide red, green, and blue signals directly, as indicated in Fig. 3. By colorimetric techniques which are too complex to be explained here, it is possible to compute precisely the optimum shapes for the spectral sensitivity curves of the three pick-up tubes to yield the best color fidelity for the average observer. The sketches in Fig. 3 give a rough indication of the optimum spectral response curves (but readers familiar with colorimetry will note that the secondary response lobes have been eliminated). Note that the peaks of the curves occur in roughly the red, green, and blue portions of the spectrum, but that they overlap appreciably. The relative sensitivities of the three camera tubes are usually adjusted so that the output voltages are equal when a white or neutral is being scanned. In analyzing and discussing television systems, it is customary to express signal voltages in relative or percentage units, such that 100% voltage in all three channels corresponds to the brightest white the system can reproduce.

All systems of color television are based on the same colorimetric principles, regardless of the physical construction of the cameras and receivers or the methods used to combine the primary color images. In principle, the various systems differ only in the solutions they offer for the multiplexing

problem involved in transmitting the signals from camera to receiver. The simplified block diagram in Fig. 3 shows red, green and blue signals entering the transmission system. It should be appreciated that these signals may be operated upon in a great variety of ways within the transmission system; the only requirement is that they must remain sufficiently independent that red, green and blue signals suitable for the control of a tricolor reproducer can be recovered at the receiving end. A complete discussion of all proposed multiplexing methods for color television is

beyond the scope of this paper, so we shall confine our attention to the techniques currently used in the RCA color television system under the FCC signal specifications.

In keeping with the principle that education is best accomplished by leading the student from the known to the unknown in gradual, easy-to-follow steps, the writer shall attempt to explain the RCA color television system by showing how a black-and-white television system can be transformed, step-by-step into a compatible color system. The reader should keep in mind that our ultimate goal is to develop a color television system meeting the colorimetric requirements shown in Fig. 3 as well as the other requirements listed in the introduction to this paper. While particular attention will be directed here to the *difference* between black-and-white and color systems, the reader should appreciate that there are fundamental similarities. For example, the methods of scanning and of maintaining synchronism between the camera and the receiver are the same for both black-and-white and color television systems.

Satisfying the Compatibility Requirement

A black-and-white television system reduced to the simplest possible terms is shown in Fig. 4. The system consists, in essence, of a black-and-white kinescope connected to a camera tube through a transmission channel. It must be understood, of course, that means are provided for scanning the image areas of both the kinescope and the camera tube in synchronism, and

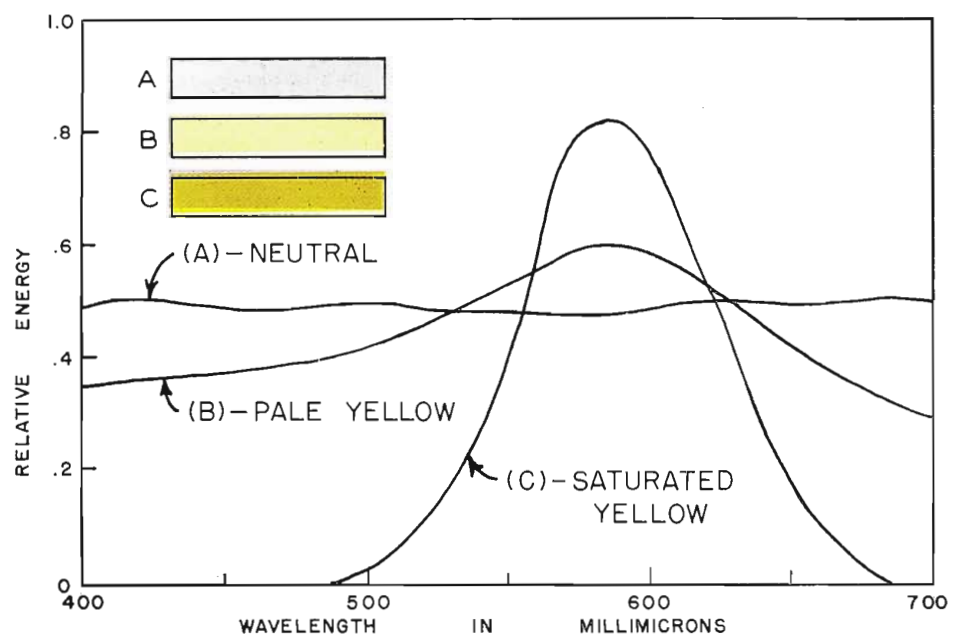

FIG. 2. Chart of the visible spectrum, showing how hue and saturation are controlled by spectral distribution.

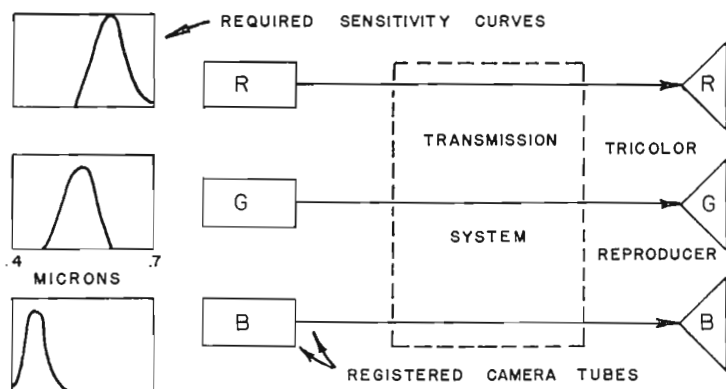

FIG. 3. Block diagram showing the basic colorimetric features of a color television system.

that other means are provided for transmitting an audio signal from the camera location to the receiver. For optimum performance the camera tube should have a spectral sensitivity curve matching that of the eye (the luminosity function) so that the various colors in an original scene are reproduced in appropriate tones of gray corresponding to their relative brightnesses. The monochrome signal from such a camera tube, which we shall designate as M throughout the rest of this paper, may be regarded as a *luminance* signal.¹

If the signal produced by a color television system is to provide service to black-and-white receivers, we should devise some method of producing a luminance signal from the output of the color camera. We might attempt to use the signal obtained from just one of the three camera tubes, but we would quickly discover that this technique is unsatisfactory because certain colors would be rendered in inappropriate tones of gray. For example, if we were to use the signal from the green camera tube to control black-and-white receivers, we would

¹ *Brightness*, strictly speaking, is a psychological sensation not susceptible to exact measurement. *Luminance*, which we can measure by taking into account the intensity of the radiation from the color in question and also the spectral response of the typical eye, indicates only the strength of the stimulus that controls the brightness sensation. While luminance can be measured in absolute units (the foot-lambert being the most common) it is generally preferable to use relative units; i.e., the luminances in a television image can best be expressed as percentage of the maximum highlight luminance. The reason for this is that the normal observer tends to perceive as "white" the brightest area in his field of vision, even though the actual intensity of the brightest area may be much lower under some circumstances than others.

find that both red lips and blue skies would be too dark in the black-and-white images, because the green pick-up tube has very little response for either red or blue light. We can, however, produce a very reasonable luminance signal by adding the signals from the red, green, and blue camera tubes in proportion to the relative luminosities of the primaries.

The three primaries recommended as standards for color television do not appear equally bright because they are located in different parts of the spectrum, and hence stimulate the brightness sensation by different amounts. If the three primaries are mixed together in the right proportions to produce a white matching typical daylight, it is found that the green primary (located at the center of the visible spectrum) accounts for 59% of the brightness sensation, while the red and blue primaries account for only 30% and 11%, respectively.

If the red, green, and blue spectral sensitivity curves shown (in very rough form) in Fig. 3 are added, wavelength by wavelength, in the ratio of 30% red, 59% green, and 11% blue, the resulting curve has the same shape as the luminosity function, which is the optimum curve for a black-and-white camera, as shown in Fig. 4. We can accomplish this addition electrically by combining the signals from the red, green, and blue camera tubes in a simple resistance mixer, as shown in Fig. 5, to produce a monochrome or M signal equal to $.30R + .59G + .11B$. (The three weighing factors have been adjusted so that their sum is unity. Consequently, when a peak white is being scanned, and $R = G = B = 100\%$, the M signal also equals 100%.) If the

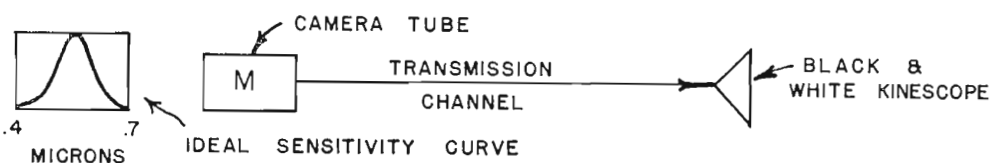

FIG. 4. Simplified block diagram for a monochrome television system.

three camera channels were linear—that is, if the signal voltages were strictly proportional to the light inputs—the M signal would be identical to that produced by a linear black-and-white camera with optimum spectral response. In actual practice, the camera signals are deliberately made non-linear to compensate for the non-linearity of the kinescopes used in receivers, but the M signal is still a good approximation to the output of a black-and-white camera.

From the preceding discussion, we may draw the conclusion that it is possible to make a color television system compatible in the sense of providing service to black-and-white receivers by cross-mixing the red, green, and blue primary signals to produce a monochrome signal according to the

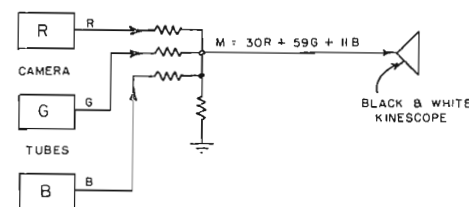

FIG. 5. Block diagram showing how a color camera may be connected to a black and white kinescope.

equation $M = .30R + .59G + .11B$. This signal should be generated in accordance with the existing scanning standards (i.e., 525 lines, 60 fields/second, 30 frames/second), and be treated exactly like a standard monochrome signal with respect to bandwidth and the addition of synchronizing and blanking pulses. If we were to stop our development at this point, we would not yet have a color television system; so far we have developed only a reasonable method for connecting a color camera to a black-and-white receiver, as shown in Fig. 5. In order to produce color pictures, we must provide at least two other independent signals in addition to the M signal, since color involves three independent variables. If we are to continue to satisfy the requirement of compatibility, we must find means for transmitting these additional signals through a standard broadcast channel without interfering with the monochrome signal.

Choice of Signal Components

The choice of signals to accompany the M or monochrome signal in a compatible color system can best be determined by considering the requirements of a color receiver. One requirement a color system should satisfy is what is often called "reverse compatibility"; that is, the color re-

ceiver should be capable of producing a black-and-white picture from a standard monochrome signal. This requirement is readily satisfied by arranging the receiver circuits so that a monochrome signal may

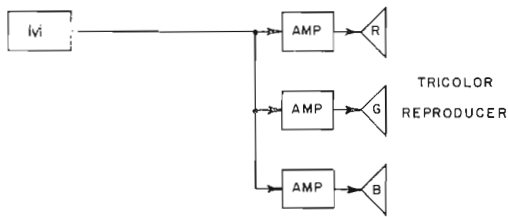

FIG. 6. Block diagram showing how a monochrome camera may be connected to a tri-color reproducer.

be applied to all three kinescope elements in equal proportions, as shown in Fig. 6. Whenever the red, green, and blue elements of a tricolor reproducer are excited in a one-to-one-to-one ratio, a white or neutral is reproduced. (Note: This 1:1:1 ratio applies only to *normalized* voltages such that 100% voltage on all three kinescope elements produces a maximum white. The *absolute* drive voltages may be different because of the different efficiencies of the various phosphors.)

The additional signals required to produce a *color* picture are indicated in Fig. 7. From an inspection of the figure, it should be obvious that we can provide the R, G, B signals required for the color kinescope if we have R-M, G-M and B-M signals which may each be added to M in the simple arrangement shown. R-M, G-M, and B-M are called *chrominance* or *color-difference* signals; when considered in combination, they indicate how each color in the televised scene differs from a monochrome color of the same luminance. We still retain the feature of reverse compatibility, because when the receiver is tuned to a transmission where the R-M, G-M, and B-M signals are absent, the monochrome signal is still applied to the kinescope elements in equal proportions, thus producing a black-and-white picture. (An adder

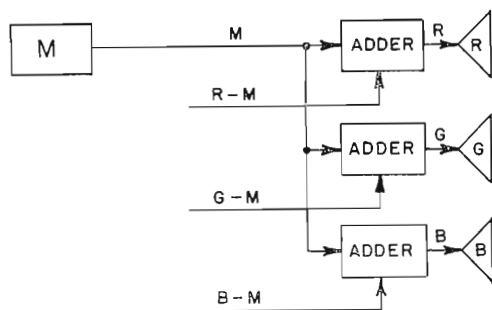

FIG. 7. Block diagram showing the signal requirements for a compatible color receiver.

usually consists of a pair of amplifier stages with separate grids but a common plate load impedance.)

A superficial study of Fig. 7 would seem to indicate that a total of *four* signals are required for our compatible system. Since color has only three variables, it seems reasonable that it should be possible to achieve the desired results with only *three* independent signals. A study of the R-M, G-M and B-M chrominance signals shows that they are not independent—when any two of them are known, it is always possible to solve for the third. This fact may be proved by first writing the signals in terms of their red, green, and blue components and then testing the resulting equations by any of the standard tests for independence to see if they constitute a set of three independent, simultaneous equations. It was noted earlier that $M = .30R + .59G + .11B$. Therefore:

$$\begin{aligned} R-M &= .70R - .59G - .11B \\ G-M &= -.30R + .41G - .11B \\ B-M &= -.30R - .59G + .89B \end{aligned}$$

These equations *cannot* be solved for R, G, and B in terms of R-M, G-M, and B-M, but they *can* be solved to find any of the chrominance signals in terms of the other two. For example,

$$G-M = -.51(R-M) - .19(B-M)$$

In the arrangement shown in Fig. 8, this equation is solved automatically and con-

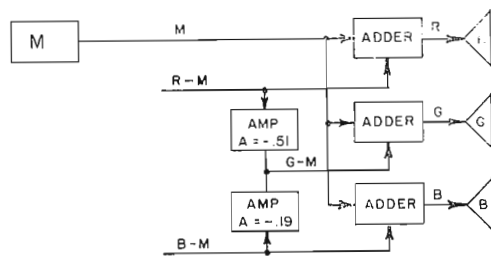

FIG. 8. Block diagram showing how a compatible receiver may be controlled by only three input signals.

tinuously by a simple cross-mixing circuit that combines appropriate amounts of the R-M and B-M signals. The separate amplifier stages in the mixer inherently provide the polarity reversals implied by the minus signs in the equation. The arrangement shown in Fig. 8 is fully equivalent to that shown in Fig. 7, but the receiver requires only three input signals instead of four. It should be noted that G-M might have been chosen as one of the two chrominance signals to be transmitted, but R-M and B-M are the two that were actually selected for use in the system.

Let us now direct our attention toward the transmitting end of the system to see how the chrominance signals may be obtained from a color camera. We have already shown (in Fig. 5) how a luminance or monochrome signal may be obtained by cross-mixing the R, G, B signals in a simple resistance mixer. Fig. 9 shows how a phase inverter and a couple of adders may be employed to provide all the signals needed to produce a color picture. Our problem now is to find means for transmitting the R-M and B-M signals from the camera to the receiver without causing interference to the M signal.

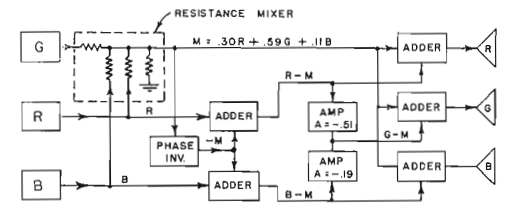

FIG. 9. Block diagram showing complete matrix operations for compatible color television system.

The Frequency Interlace Principle

Fig. 10 shows how a six-megacycle broadcast channel is utilized by a standard monochrome picture signal and the associated frequency-modulated sound signal. This is the same channel that must be used for all the information required for our compatible color television system. Since we have already noted that the M component of our color signal should be treated in all respects like an ordinary monochrome signal, it seems, at first glance, that this one component alone will completely fill the available channel, leaving no spectrum space for the additional chrominance signals. It has been found, however, that an additional carrier may be transmitted within the same spectrum space occupied by the luminance signal without causing objectionable interference, provided the added carrier is separated from the main picture carried by some odd multiple of one-half the line frequency. This added carrier may be modulated by a video signal, and thus made to convey additional

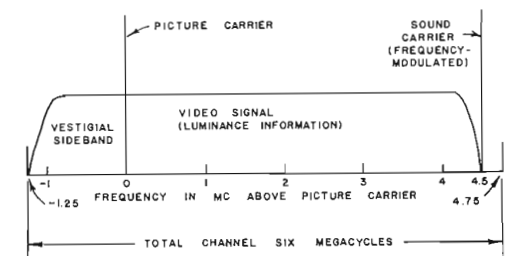

FIG. 10. Sketch of a standard television broadcast channel.

information. This multiplexing technique is commonly known as *frequency interlace*.

In practice, the use of an additional transmitter for a color television system is avoided by using the subcarrier principle. That is, the extra information to be transmitted on the added carrier is first modulated upon a *subcarrier* of less than 4 MC somewhere within the studio, and this modulated subcarrier is then added directly to the monochrome signal. Thus all the color signals are combined into one signal before leaving the color studio, so only one transmission line and one transmitter are required. The subcarrier frequency is chosen as an odd multiple of one-half the line frequency, and this frequency spacing between the subcarrier and the main picture carrier is preserved when the combined signals are modulated upon the picture carrier within the transmitter.

Basically, the frequency-interlace technique is a means for exploiting the "persistence of vision" effect to permit the transmission of additional information. Persistence of vision, or the time-integrating property of the human eye, is relied upon even in monochrome television systems; it provides the illusions of smooth motion and continuous illumination from the rapid succession of still images that is actually transmitted. Fortunately for the color television system designer, visual stimuli are integrated or averaged by the eye over considerably longer periods of time for small picture areas than for larger picture areas. Consequently, interfering signals which appear only as small-area dots in the picture may be cancelled out by the eye if provision is made for reversing the polarity of the "dots" between successive scans of each area in the picture.

The clearest way to explain how frequency interlace works is by means of waveform sketches, such as those in Fig. 11. Sketch (A) shows a typical luminance signal for a very small section of one scanning line. Sketch (B) shows the modulated subcarrier signal to be transmitted during the same interval. If the subcarrier is an odd harmonic of one-half the line frequency, it reverses in polarity between successive scans (as indicated by the dotted line) because it passes through some whole number of cycles plus one-half during each frame period. The composite signal to be transmitted—the sum of (A) and (B)—is shown at (C). We shall discuss in a later section how chrominance information may be modulated on the subcarrier and later removed from it by demodulation, but at this point we should note that the signal shown at (C) is the one that would be ap-

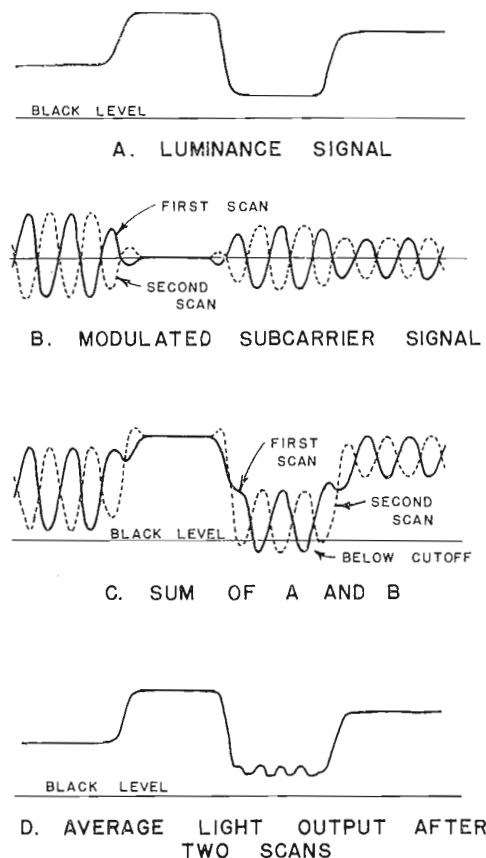

FIG. 11 (A, B, C, D). Waveform sketches illustrating the frequency-interlace principle.

plied to black-and-white kinescopes when ordinary monochrome receivers are tuned to a compatible color transmission. The signal that should ideally be applied to the kinescopes is the luminance signal shown at (A); the subcarrier component is spurious whenever it reaches a kinescope instead of a demodulator. Nevertheless, the interference caused by the subcarrier is not objectionable, because it is effectively cancelled out by the persistence of vision. The effective response of the eye is controlled not so much by the instantaneous stimulation provided by any one scan as by the *average* stimulation after two or more scans. The average signal after two scans is shown at (D). Note that this is identical to the original luminance signal except in cases where the composite signal overshoots below black level; the kinescope is incapable of producing negative light to cancel the positive peaks.

In the interests of accuracy, it should be noted that cancellation of spurious signals by the frequency interlace technique is seldom 100% complete, for the following reasons: (1) For perfect cancellation, the sinusoidal electrical signals shown in Fig. 11 should be transformed to sinusoidal light patterns before reaching the eye; in practice, the electrical signals are applied

to non-linear kinescopes which effectively alter the waveforms to make perfect cancellation impossible (the overshoots below black level are an exaggerated case of this general effect). (2) The persistence of vision effect is not perfect over an interval of 1/15th of a second (two frame periods). (3) When there is motion in the image, the waveforms change slightly from frame to frame. On the other hand, the lack of perfect cancellation is not objectionable in practice because: (1) Many mass-produced receivers have relatively low response at the subcarrier frequency specified by FCC Standards (roughly 3.6 MC), so the subcarrier component is pretty well attenuated before it reaches the kinescope. (2) The signals modulated on the subcarrier have the same image geometry as the luminance signal, so any crosstalk resulting from imperfect cancellation does not confuse the picture but simply adds dots or alters gray-scale values in certain areas. (3) The dot pattern resulting from imperfect cancellation corresponds to the second harmonic of the subcarrier, and is therefore even finer in texture than the line structure and cannot be resolved at normal viewing distances.

The Two-Phase Modulation Technique

The reader may wonder at this point how we may transmit not one but two chrominance signals (both R-M and B-M) by means of the frequency-interlace technique. It is not desirable to use two separate frequency-interlaced carriers, because the difference frequency between them would be an *even* multiple of one-half the frame frequency, and hence would have no tendency to be self-cancelling. The difference frequency would be produced as a "beat" between the two carriers whenever the signal is passed through any non-linear device, such as a kinescope. The need for two carrier frequencies can be eliminated by the use of the two-phase modulation technique, which is equivalent to the use of two carriers of the same frequency but with a phase separation of 90 degrees.

The basic equipment needed for a two-phase modulation system is shown in Fig. 12. For purposes of illustration, let us assume that the carrier frequency is approximately 3.6 MC; we shall discuss the factors involved in choosing a precise subcarrier frequency in a later section. In the arrangement shown, two independent signals are modulated upon two carriers of the same frequency but 90 degrees apart in phase. The outputs of the two transmitter modulators are added together to feed a common transmission channel. The two independent components are separated at the receiving

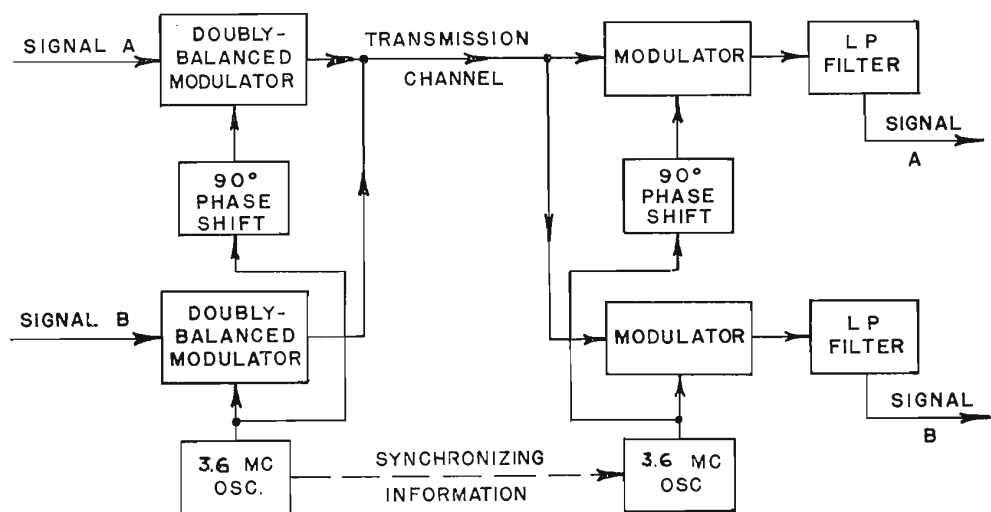

FIG. 12. Simplified block diagram for a two phase modulation system.

end by means of two additional modulators (operated as *synchronous detectors*) which multiply the incoming signal by two carriers having the same relative phases as the original carriers at the transmitter. The carriers at the receiver must be supplied by an oscillator which is maintained in frequency and phase synchronism with the master oscillator at the transmitter; some form of special synchronizing information must be transmitted for this purpose.

The two-phase modulation technique is basically a means for using the two sidebands surrounding a single carrier frequency for the transmission of two variables. It is common knowledge among radio engineers that double-sideband transmission is ordinarily wasteful of spectrum space, since the information contained in the two sidebands is identical. Whereas an ordinary AM wave varies in one respect only (i.e., in amplitude), the signal transmitted by a two-phase modulation system varies in both amplitude and phase.

The most serious disadvantage of the two-phase modulation technique is the need for carrier reinsertion at the receiver. This characteristic makes the technique economically undesirable in many applications, but its use in compatible color television systems is entirely feasible because of the happy fact that time is available (during

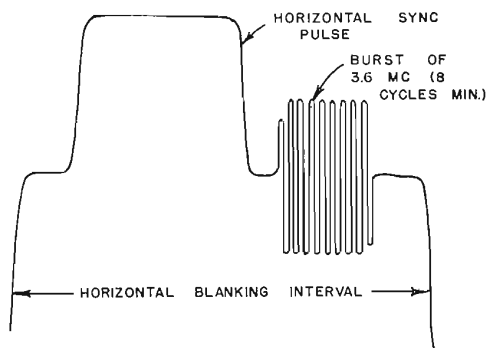

FIG. 13. Waveform sketch for the horizontal blanking interval, showing the color synchronizing burst.

the blanking intervals necessarily provided in a television system) for the transmission of carrier-synchronizing information. Under the FCC Color Signal Specifications, the subcarrier-synchronizing information consists of "bursts" of at least 8 cycles of the subcarrier frequency at a predetermined phase transmitted during the "back porch" interval following each horizontal synchronizing pulse, as shown in Fig. 13. The "bursts" are separated from the rest of the signal at the receiver by appropriate time-gating circuits, and are used to control the receiver oscillator through a phase detector and reactance tube.

The need for carrier reinsertion in a compatible color television receiver need not be regarded as a serious disadvantage when account is taken of the fact that an important advantage—suppressed carrier transmission—may be gained without further complexity. In ordinary AM broadcasting, fully half of the radiated energy is in the carrier component, which transmits no information by itself but simply provides the frequency reference against which the sidebands may be heterodyned in simple diode detectors to recover the intelligence in the sidebands. If a locally-generated carrier is available in the receiver, then there is no need to transmit a carrier along with the sidebands. In a compatible color television system, suppression of the subcarrier not only saves signal energy but also reduces the possibility of spurious effects in images, since the complete subcarrier component goes to zero (and hence cannot cause interference) whenever the camera scans a white or neutral surface such that both R-M and B-M equal zero.

A brief review of some of the characteristics of amplitude modulators may be appreciated at this point before we undertake

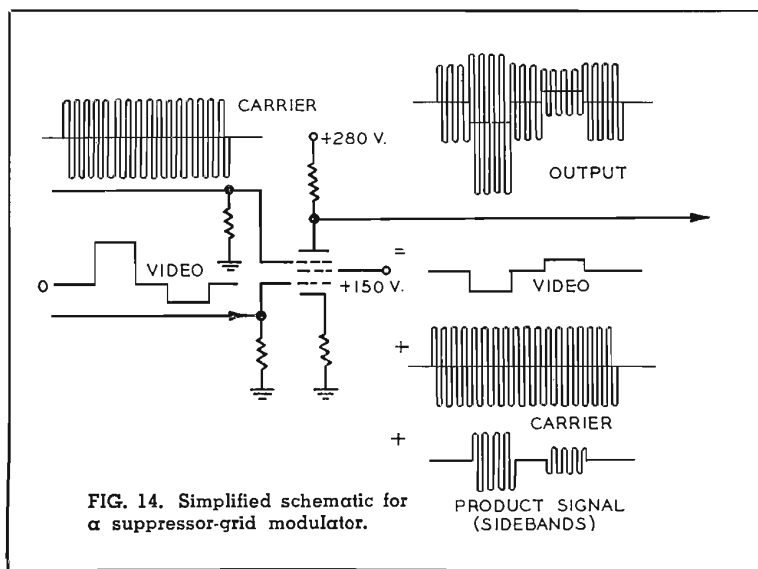

FIG. 14. Simplified schematic for a suppressor-grid modulator.

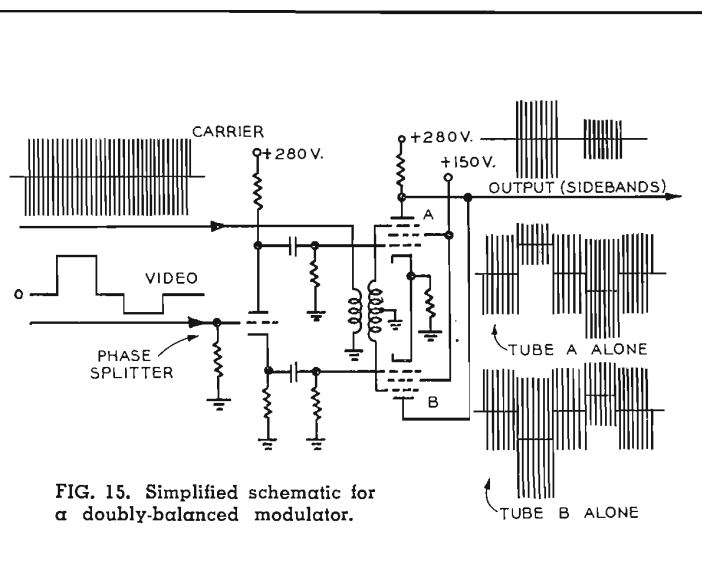

FIG. 15. Simplified schematic for a doubly-balanced modulator.

further discussion of suppressed-carrier transmission and two-phase modulation. Let us confine our attention here to the one type of modulator most commonly used in color television at the present time—the suppressor-grid type. The basic circuit is shown in Fig. 14, and its operation may be described rather crudely as follows: The number of electrons leaving the cathode of the tube is roughly proportional to the signal voltage on the first grid (assuming reasonable linearity), since the screen grid prevents the third grid and the plate from exercising any significant influence on the space current. The *proportion* of the emitted electrons that reach the plate instead of the screen is roughly proportional to the relative voltage on the No. 3 grid. If the No. 3 grid is positive, the screen grid collects only a few of the electrons, and most of them are attracted to the plate, which is of higher potential. If the No. 3 grid is highly negative, however, it may make a potential barrier so great that no electrons can pass through to the plate and all of them are collected by the screen. Therefore, the plate current contains a component proportional to the *product* of the signal on the No. 1 grid and that on the No. 3 grid. The suppressor-grid modulator, like most simple modulators, produces an output consisting of three components as indicated in Fig. 14. In addition to the product component, both the original video signal and the carrier signal appear (with polarity reversals) as if the tube were a simple amplifier as well as a modulator. The relative amplitudes of the three components depend upon the tube type, the relative input levels, and the bias conditions.

In many modulator applications, the original *intelligence* signal (video or audio, as the case may be) is removed at the output by filtering. For example, in AM sound broadcasting, the output of the modulator is usually a tuned circuit which offers almost no impedance to the original audio frequencies. Removal of the *carrier* component by filtering is very difficult in most practical circuits, since it is difficult to make a filter “sharp” enough to attenuate the carrier without also affecting the sidebands. As an alternative to filtering, the method of cancellation may be used to remove the original intelligence signal, the carrier, or both original components from the output of a modulator. A typical doubly-balanced modulator, which uses the method of cancellation, is shown in simplified form in Fig. 15. The circuit consists essentially of two modulator tubes with opposite-polarity inputs and a common output. The input components cancel each

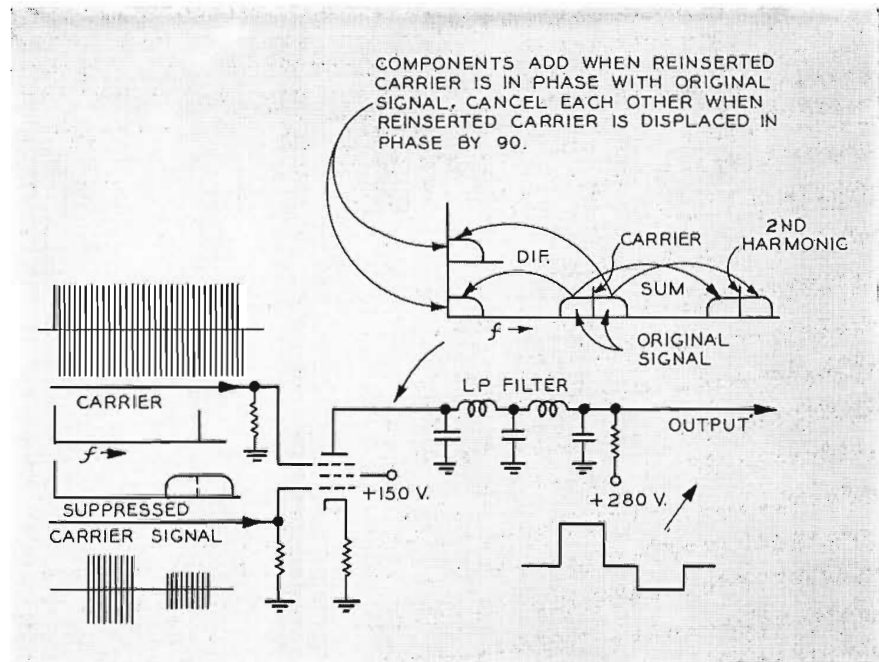

FIG. 16. Simplified schematic for a suppressor-grid modulator used as a synchronous detector.

other in the common output, but the product components reinforce each other. Therefore, the output consists only of a pair of sidebands with no carrier. A center-tapped transformer may be used as a phase splitter for the carrier signal, but a tube-type phase splitter is required for the intelligence signal if it involves frequency components of more than a few KC. It should be noted that if such a modulator circuit is to be used for television signals with significant DC components, clamps or DC restorers must be used at each modulator grid. Circuits of this basic type have been widely used in experimental color television studio equipment.

One significant difference between an ordinary AM wave and a suppressed-carrier signal is that the latter goes through a polarity reversal every time the intelligence signal passes through zero. For this reason, an ordinary diode or envelope detector cannot be used to demodulate a suppressed-carrier signal. As long as both sidebands are transmitted, however, the suppressed-carrier signal remains of constant phase even though it may swing both positive and negative. The intelligence signal may be recovered by the process of *synchronous* detection.

The operation of a suppressor-grid modulator as a synchronous detector is illustrated by Fig. 16. Detection, like modulation, is essentially a heterodyning process whereby signals may be moved to new positions in the frequency spectrum. In a modulator, an intelligence signal is heterodyned

against a carrier, and the sum and difference frequencies appear as a pair of sidebands surrounding the carrier. In a detector, the pair of sidebands is heterodyned against a carrier (whether that carrier was transmitted along with the sidebands or reinserted at the receiver), and again sum and difference frequencies are produced. The sum frequencies consist of a pair of sidebands surrounding the second harmonic of the carrier, and ordinarily are of no value. The difference frequencies, however, represent the original intelligence. As noted in Fig. 16, the difference frequencies from the two sidebands reinforce each other if the carrier at the detector is in phase with the original carrier, but they cancel each other if the carrier at the detector is 90 degrees out of phase with the original carrier. This last-mentioned characteristic of synchronous detectors is the basic principle on which the two-phase modulation technique rests. If the input to a synchronous detector consists of the sum of two suppressed-carrier signals in phase quadrature, the phase of the carrier applied to the detector may be adjusted to cause the difference frequencies representing one of the two components to add while the difference frequencies representing the other signal will cancel out. Obviously, a second detector can be used with a carrier displaced by 90 degrees to recover the signal that is cancelled in the first detector.

A vectorial representation of the two-phase modulation technique is shown in Fig. 17. It is conventional to portray the two sidebands of an amplitude-modulated

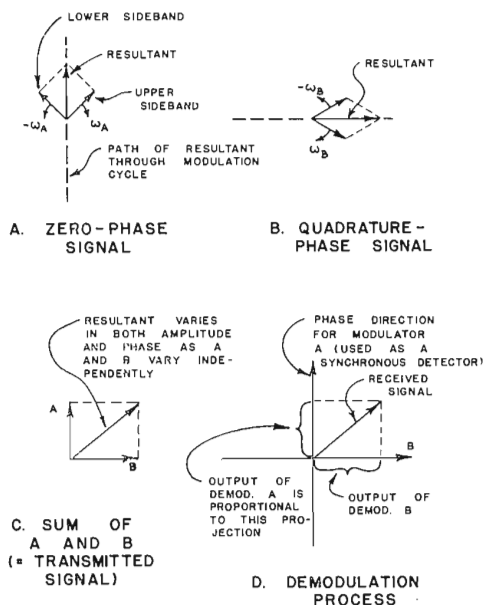

FIG. 17 (A, B, C, D). Vector diagrams illustrating the two-phase modulation technique.

wave as vectors which revolve with the same angular velocity but in opposite directions *relative to the carrier*. The carrier is suppressed in Fig. 17 but each sketch must be regarded as revolving about its origin at the carrier frequency. The sketch at (A) shows the two sidebands produced by suppressed-carrier modulation of a carrier of reference phase. Note that the resultant always fall somewhere on the vertical line, since the quadrature components of the sidebands cancel each other at all times. A different signal, B, modulated in suppressed-carrier fashion upon a second carrier in phase quadrature produces the pair of sidebands shown in sketch (B). The resultant in this case is also of constant phase. The sum of both resultants is shown in sketch (C). Since A and B vary independently, the transmitted signal may have any phase angle at any given instant. As shown in sketch (D), the original signals may be recovered by synchronous detectors each of which is sensitive only to the projection of the vector for the transmitted signal into the phase reference direction corresponding to the phase of the reinserted carrier. Since the projection of the B component into the A direction is zero, and the projection of the A component into the B direction is also zero, the two original signals may be recovered without crosstalk as long as both sidebands are transmitted.

The need for double sidebands in a two-phase modulation system is illustrated by Fig. 18, which shows the vectors corresponding to amplitude modulation of a single suppressed carrier. As long as both sidebands are transmitted with equal lev-

els, the phase of the resultant remains constant, as shown in sketch (A), and the projection of the resultant into the $\pm 90^\circ$ phase direction remains at zero (indicating a lack of crosstalk). Sketch (B) shows what happens when the sidebands become unequal. The path of the resultant through the modulation cycle is now an ellipse, rather than a straight line, and the projection of this ellipse into the $\pm 90^\circ$ phase direction represents crosstalk. If one sideband is completely missing, the path of the resultant becomes a circle as shown in sketch (C), and the amplitude of the crosstalk component becomes equal to the desired component. While it is possible to devise means for cancelling this crosstalk (by making use of the fact that there is a 90° phase separation between the desired and crosstalk components), it is better to avoid it entirely by providing double sidebands for two-phase modulated signals.

For the benefit of readers familiar with trigonometry, a mathematical proof of the two-phase modulation technique is presented as Appendix A.

Adjustment of Relative Signal Levels

It should now be quite apparent that we can satisfy the requirements for a compatible color television system by cross-mixing (or *matrixing*) the R, G, B pri-

mary signals to produce M, R-M, and B-M signals, by treating the M signal like an ordinary monochrome signal, by modulating R-M and B-M in phase quadrature upon a frequency-interlaced subcarrier, and by adding this modulated subcarrier to the M signal for transmission. Before we can complete the system development, however, we must decide at what relative levels the various signal components are to be transmitted, and what bandwidths should be allotted to the various signal components. The factors involved in the former decision can be determined by a study of the waveforms resulting from the scanning of simple color bar patterns.

Fig. 19 shows a color bar pattern containing areas in the three primary colors, in the three complementary colors formed by pairs of primaries, and in maximum white produced by adding all three primaries. The red, green, and blue horizontal frequency waveforms that would be produced by scanning this pattern are shown at the left (in practice, such color bar signals for test purposes are usually generated artificially by multivibrators). On the right are the M, R-M, and B-M signals that are produced by cross-mixing the R, G, B signals in the proper ratios. The M signal is identical to that which would be produced by a linear black-and-white camera with optimum spectral response.

Fig. 20 shows the derivation of the composite signal waveform that would be produced if all three signal components were transmitted at unity level relative to each other. The R-M and B-M signals are modulated upon subcarriers of the same frequency but 90° apart in phase. When the two subcarrier components are added, a resultant corresponding to the vector sum of the two components is produced for each color bar interval. On the scale used in Fig. 20, only the envelope of this subcarrier signal can be shown. When this resultant is in turn added to the M component, the signal shown in the bottom waveform sketch is produced (note that sync and burst waveforms are also shown). A study of this complete waveform quickly shows that it is undesirable to transmit all three components at a relative level of unity, because the addition of the subcarrier signal to the luminance signal causes "overshoots" into the whiter-than-white and blacker-than-black signal regions, greatly increasing the total amplitude range required for the composite signal. A signal of this sort, requiring about 1.84 times as much amplitude range as a normal black-and-white signal, could not be completely compatible with the existing black-and-white broadcast service, because

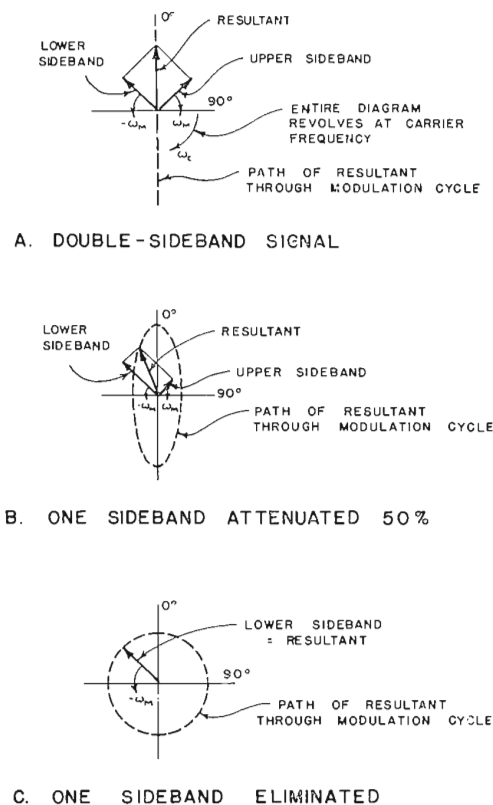

FIG. 18 (A, B, C). Vector diagrams illustrating the need for double sidebands in a two-phase modulation system.

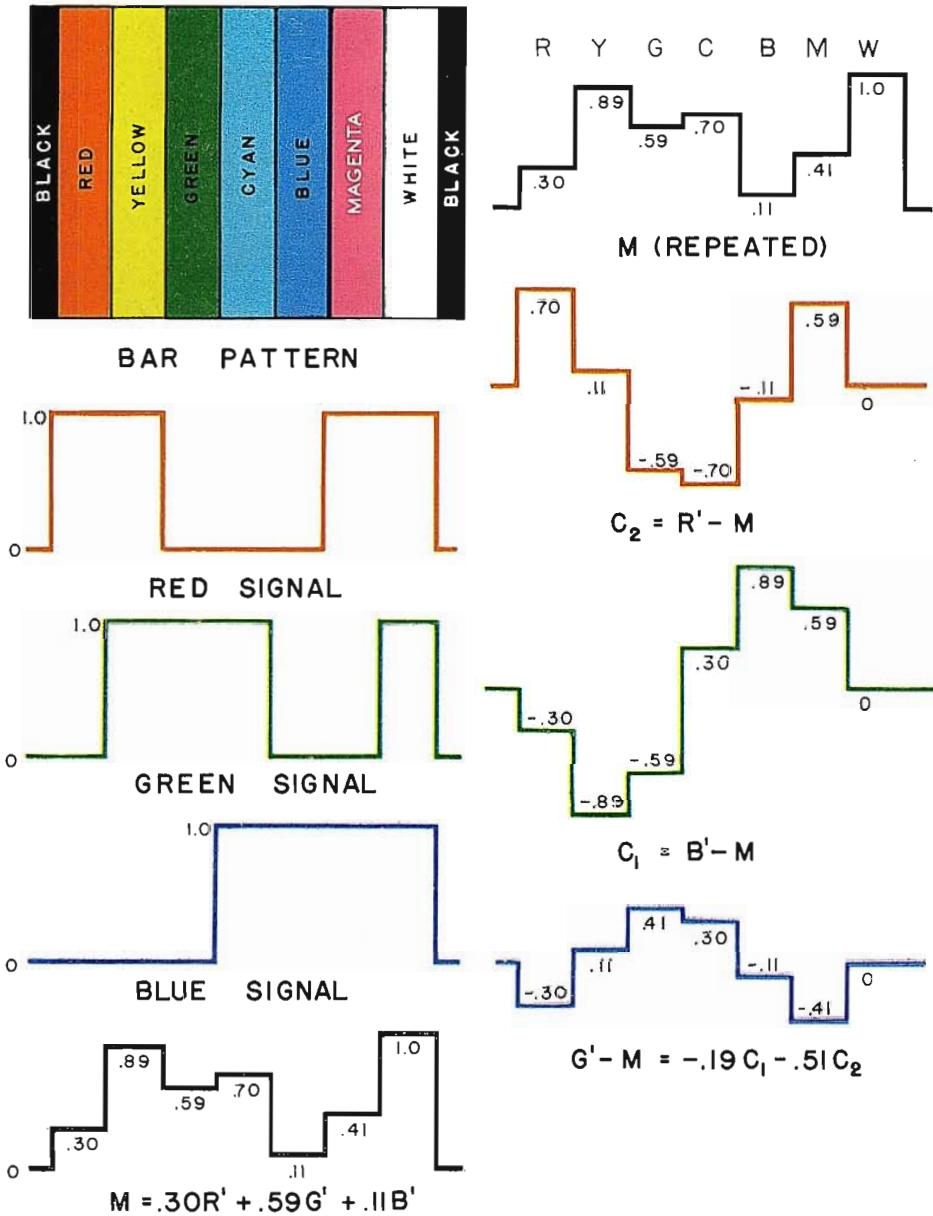

FIG. 19 (above). A typical bar pattern and horizontal-frequency waveforms illustrating the operation of a compatible color television system.

the only way this signal could be passed through existing broadcast transmitters (and certain pieces of studio equipment) would be by reducing its absolute amplitude, and reducing the effective modulation of the picture carrier.

The solution to the relative-amplitude problem used in the FCC Signal Specifications is shown in Fig. 21. The M component is transmitted at the same relative level as an ordinary black-and-white signal, so that no adjustment need be made of receiver contrast controls when a switch is made from a black-and-white to a color

FIG. 20. Bar-pattern waveforms showing the derivation of the composite signal for a system in which all components are transmitted at unity level relative to each other.

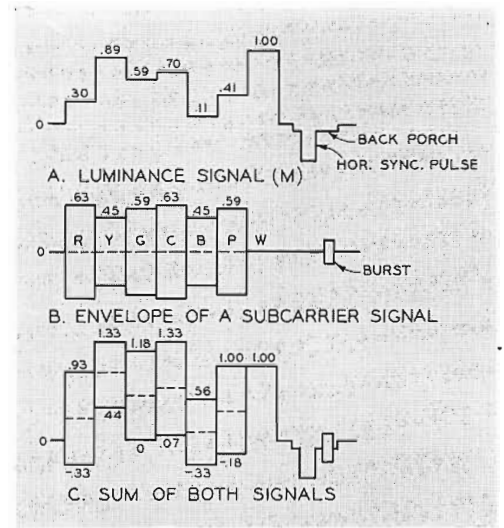
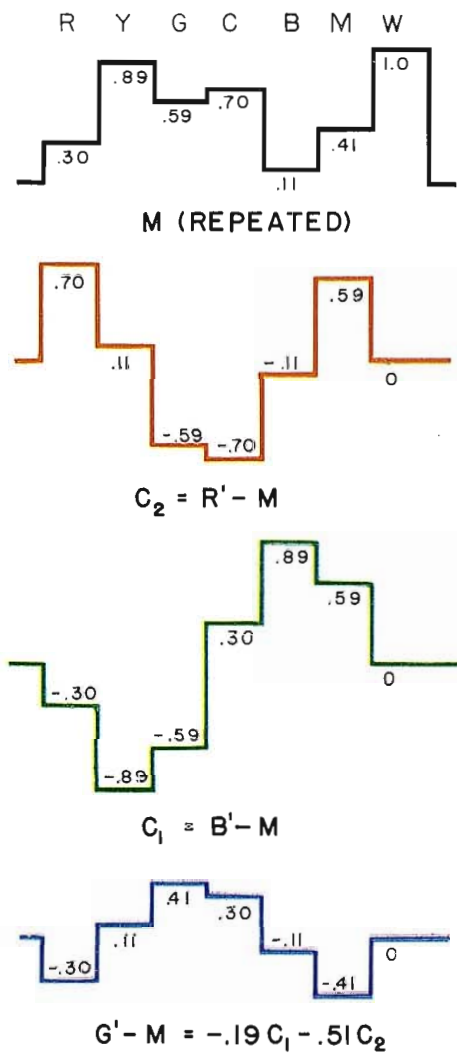
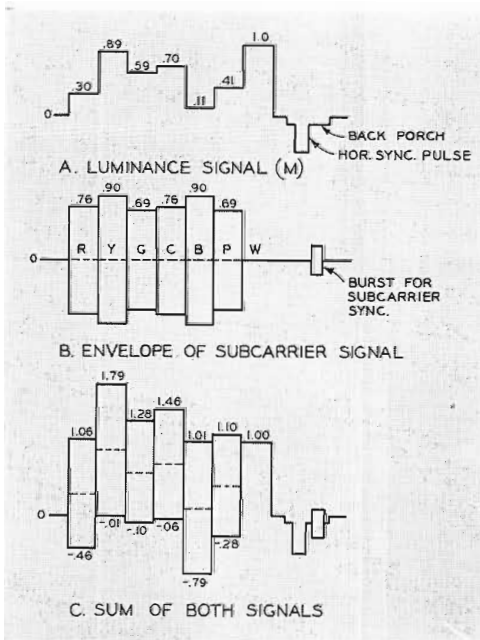

FIG. 21. Bar-pattern waveforms showing the derivation of the composite signal for a compatible system in which the (R-M) and (B-M) signal levels are reduced to 88% and 49%, respectively, to limit overshoots to 33%.

program. The amplitude of the R-M and B-M components are reduced to 87.7% and 49.3%, respectively, however, so that the maximum subcarrier overshoots in the composite signal never exceed 33% of the black-to-white range. It has been found through field test experience that overshoots of this magnitude can be handled in a practical system without impairing performance. Highly saturated colors producing whiter-than-white subcarrier overshoots that cannot be passed without distortion through television transmitters are almost never encountered in actual television scenes. It would be undesirable to reduce the subcarrier amplitudes enough to eliminate all overshoots, because then the signal-to-noise performance of the chrominance channels would be rather poor.

Adjustment of Bandwidths

One great advantage of a simultaneous color television system (in which all three signal components are transmitted continuously) as opposed to a sequential system (in which a single transmission path is time-shared by the three components) is that the total available bandwidth may be allotted to the signal components in proportion to the amount of information required by the eye from those signal components. The amount of information (i.e., the amount of pictorial detail) that may be transmitted by the M or luminance component of a compatible color television signal is essentially the same as for a standard black-and-white system, and hence the resolution capabilities of the two systems are about the same. The amount of chrominance information that may be



transmitted depends, in large measure, upon the choice of subcarrier frequency. It should be noted here, however, that the requirements for chrominance information are much less than for luminance information. Classic experiments by Bedford of RCA Laboratories and by other research workers have shown that the eye's acuity for differences in hue and saturation is only about 20 to 50% of the acuity for brightness differences.

There are two reasons why it is desirable to make the subcarrier frequency in a compatible color television system as high as possible: (1) Most mass-produced receivers have video response curves which fall off rather rapidly for the higher video frequencies, so a high subcarrier frequency would be attenuated more (and hence be less likely to cause spurious effects in black-and-white pictures) than a lower frequency. (2) The dots produced by imperfect cancellation of the subcarrier are finer in texture, and hence less visible, the higher the subcarrier frequency. On the other hand, a relatively low subcarrier frequency permits a wider upper sideband for the subcarrier signal, and thus increases the bandwidth available for transmitting two independent chrominance components.

In order to utilize the frequency-interlace principle to best advantage, the precise subcarrier frequency should be harmonically related to one-half the line frequency by some odd number which can be factored into smaller numbers that can be handled in practical counting circuits. The precise subcarrier frequency selected as the best compromise among all the factors involved is 3.579545 megacycles, which is 455/2 times the line frequency when the latter is defined as 2/572 times 4.5 MC, which is the standard spacing between the picture and sound carriers in the standard broadcast channel. The line frequency as defined above is 0.1% lower than the nominal 15.75 KC value used in the existing broadcast standards, but is well within the current tolerance limits. The picture-to-sound carrier spacing, the line frequency, and the subcarrier frequency are related in this way in the FCC Signal Specifications in order to minimize the visibility of any spurious beat between the subcarrier and the sound carrier; since the frequency separation between the subcarrier and sound carrier is an odd multiple of one-half the line frequency, the beat tends to cancel through frequency interlace.

In practical operation, an oscillator operating at 3.579545 MC serves as the frequency standard for the color television system. A 455-to-one counter (operating

in stages of 5, 7, and 13) in combination with a times-4 multiplier provides a 31.5 KC (nominal) signal for the control of a standard synchronizing generator. Within the sync generator, the 31.5 KC is used directly to control the equalizing pulses and the slots in vertical sync, while a divide-by-2 counter provides 15.75 KC (nominal) for horizontal sync and blanking, and a 525-to-1 counter (operating in stages of 5, 5, 7, and 3) provides 60 cycles (nominal) for the control of vertical sync and blanking.

Fig. 22 is a sketch of the video spectrum available for a compatible color television system employing a subcarrier frequency of approximately 3.6 MC. Note that double sidebands can be obtained only for components within about .5 MC of the subcarrier. Since the two-phase modulation process requires double sidebands for cross-talk-free operation, we cannot transmit two independent signals on the subcarrier with bandwidths greater than about .5 MC. A considerably wider *lower* sideband is available, however, and it is quite feasible to transmit *one* subcarrier component in this single-sideband region. As shown by the lower sketches in Fig. 22, it appears that by using two-phase modulation and frequency interlace, we have spectrum space for three independent signals within a standard television channel. One of these, which should be used for the M or luminance signal, has a bandwidth of approximately 4.1 MC. One subcarrier component, which we may call the I (or in-phase) component, may have a bandwidth of 1.5 MC if transmitted in semi-single sideband fashion (practical filter limitations make it difficult to achieve effective bandwidths much greater than half the subcarrier frequency). The other subcarrier component, which we may call the Q (or quadrature-phase) component, may have a bandwidth of .5 MC with double sidebands.

Let us now consider how we may best fit the chrominance signals into the available channels. It would be possible, of course, to transmit one of the two chrominance signals we have already discussed—say, R-M—by way of the I channel, and to transmit the other (B-M) by way of the Q channel, but this would not produce optimum results. Recent studies of human vision have shown that the acuity of the normal eye for hue and saturation differences, while always much lower than for brightness differences, is not the same for all color combinations. It seems reasonable, therefore, to make the wide-band chrominance signal in a compatible color television system correspond to those color

differences for which the eye has greatest acuity.

A useful diagram for studying this problem is the vector diagram formed by combining the subcarrier vectors for all the colors shown in Fig. 19. Such a diagram is shown in Fig. 23, with relative amplitudes and phases corresponding to those shown in Fig. 21. This diagram is roughly comparable to the color circle used by primary school children. The phase angle gives a good indication of hue, while the subcarrier amplitude, when considered along with the corresponding luminance level, gives an indication of saturation. White or neutral colors fall at the center of the diagram, since these produce no subcarrier component. Any given chrominance or color-difference signal corresponds to an axis or line on this vector diagram. For example, R-M and B-M correspond to the pair of lines indicated as the coordinate axes for Fig. 23.

Extensive experiments at the RCA Laboratories indicated that the eye has greatest acuity for color differences corresponding to an axis displaced from the R-M axis by 33°, as shown in Fig. 24. This axis corresponds to colors ranging from orange to cyan (or blue-green). It seems reasonable, therefore, to arrange the compatible color system so that I, or wide-band, component corresponds to this orange-cyan axis, while the Q component corresponds to the axis at right angles to this, along which the eye has relatively little acuity. The specifications for the I and Q signals may be determined by projecting the R-M and B-M signals (at the previously-determined levels) into the I and Q phase directions. This operation is illustrated graphically in Fig. 25. The same signal produced by adding .877(R-M) and .493(B-M) in phase quadrature can also be produced by adding I and Q in phase quadrature when

$$\begin{aligned} I &= .74(R-M) - .27(B-M) \\ Q &= .48(R-M) + .41(B-M) \end{aligned}$$

The expression for M in terms of R, G, and B may be substituted into the above equations to show I and Q as functions of red, green, and blue, as follows:

$$\begin{aligned} I &= .60R - .28G - .32B \\ Q &= .21R - .52G + .31B \end{aligned}$$

These equations show how I and Q signals may be produced directly from the camera signals at the transmitting end of the system without going through an intermediate R-M, B-M stage. It is also possible to solve the first set of equations above to show how R-M and B-M may be obtained by cross-mixing the outputs of I and Q demodu-

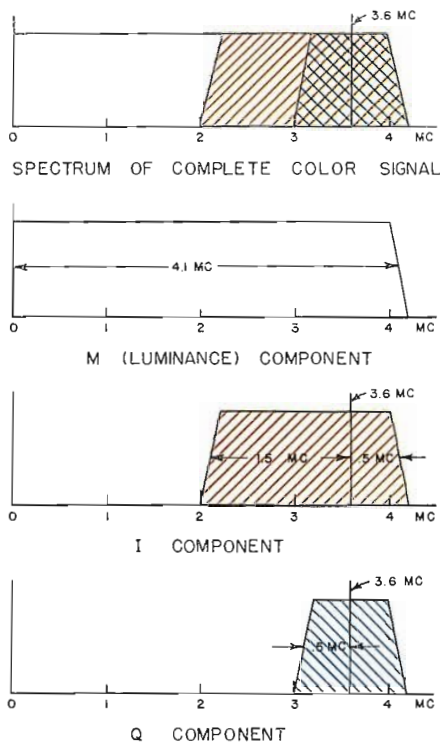

FIG. 22. Chart of the video spectrum for a compatible color television system, showing the bandwidths available for each signal component.

lators in a color receiver. The desired expressions are:

$$\begin{aligned} R-M &= .96I + .62Q \\ B-M &= -1.10I + 1.70Q \end{aligned}$$

The G-M signal needed to combine with the M signal to control the green primary in a receiver may be obtained either by cross-mixing (R-M) and (B-M) signals, as shown in Fig. 8, or by cross-mixing I and Q signals directly, as indicated by the following equation:

$$G-M = -.28I - .64Q$$

Review of Over-all System

In the preceding pages, we have discussed most of the major principles and

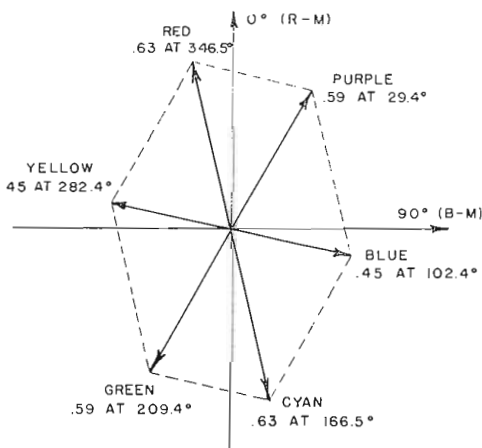

FIG. 23. Vector diagram showing the sub-carrier amplitudes and phases corresponding to six major colors.

techniques employed in the RCA color television system. It would be well at this point to look at the system as a whole to see how the various principles are inter-related. This review will also give us an opportunity to examine briefly some details of the system not covered in earlier discussions.

All major operations performed at the transmitting end of the system are shown in Fig. 26. The camera contains three pickup tubes or transducing elements which provide electrical signals corresponding to the red, green, and blue components of the scene to be televised. These signals are passed through non-linear amplifier stages (the gamma correctors) which provide compensation for the non-linearity of the kinescope elements at the receiving end of

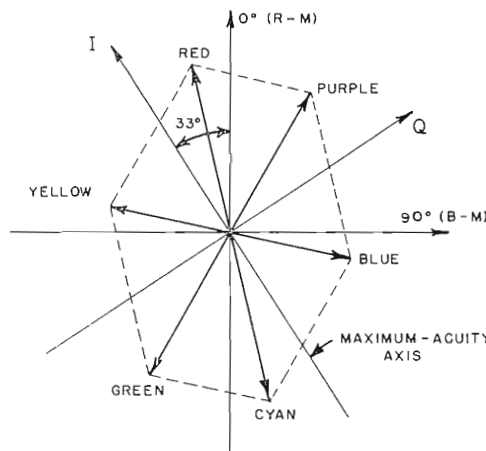

FIG. 24. Vector diagram showing location of maximum acuity axis.

the system. The gamma-corrected signals are then matrixed or cross-mixed to produce a luminance signal (M) and two color-difference or chrominance signals (I and Q). Fig. 26 shows a simple matrix circuit for producing M, I, and Q signals directly from the R, G, B signals in accordance with the equations previously given.

In the "filter section" shown in Fig. 26, the bandwidths of the M, I, and Q signals are established. The 4.1 MC filter for the luminance channels is shown in dotted lines because in practice it is not necessary to insert a special filter to achieve this band-shaping—the bandwidth of the luminance signal is usually determined by the attenuation characteristics of the transmitter, which must, of course, confine its radiation to the assigned broadcast channel. The bandwidths of 1.5 MC and .5 MC shown for the I and Q channels, respectively, are nominal only—the required fre-

quency response characteristics are described in more detail in the complete FCC Signal Specifications. Delay compensation is needed in the filter section in order to permit all signal components to be transmitted in time coincidence. In general, the delay time for relatively simple filter circuits varies inversely with the bandwidth—the narrower the bandwidth, the greater the delay. Consequently, a delay network or a length of delay cable must be inserted in the I channel to provide the same delay introduced by the narrower-band filter in the Q channel, and still more delay must be inserted in the M channel.

In the modulator section, the I and Q signals are modulated upon two subcarriers of the same frequency but 90° apart in phase. The modulators employed should be of the doubly-balanced type, so that both the carriers and the original I and Q signals are suppressed, leaving only the sidebands. Some sort of keying circuit must be provided to produce the color synchronizing bursts during the horizontal blanking intervals. To comply with the FCC Signal Specifications, the phase of the burst should be 57° ahead of the I component (which leads the Q component by 90°). This phase position, which places the burst exactly 180° out of phase with the B-M component of the signal, was chosen mainly because it permits certain simplifications in receiver designs. Timing information for "keying in" the burst may be obtained from a "burst flag generator", which is a simple arrangement of multivibrators controlled by horizontal and vertical drive pulses.

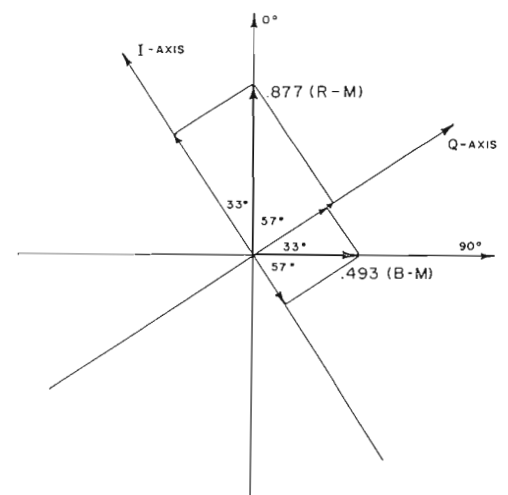

$$\begin{aligned} I &= .877 (R-M) \cos 33^\circ - .493 (B-M) \cos 57^\circ \\ Q &= .877 (R-M) \cos 57^\circ + .493 (B-M) \cos 33^\circ \end{aligned}$$

FIG. 25. Vector diagram showing how I and Q signals may be analyzed into (R-M) and (B-M) components.

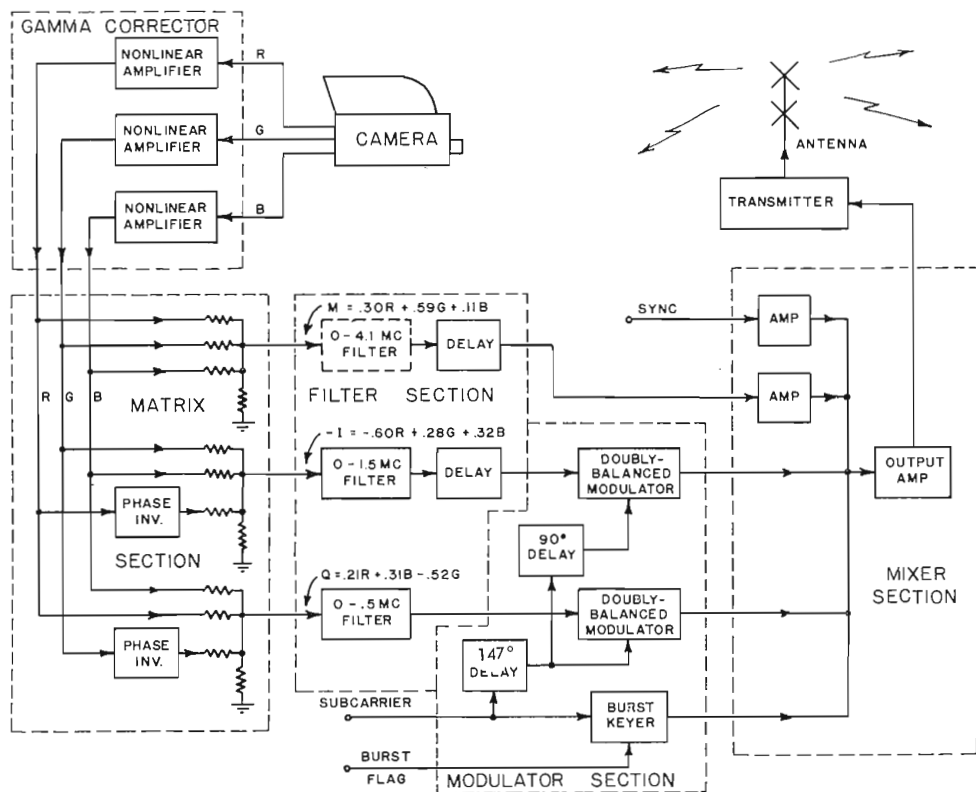

FIG. 26. Block diagram showing major operations at the transmitting end of the RCA color television system.

In the mixer section, the M signal, the two subcarriers modulated by the I and Q chrominance signals, and the color synchronizing bursts are all added together. Provision is also made for the addition of standard synchronizing pulses, so that the output of the mixer section is a complete color television signal containing both picture and synchronizing information. This signal may then be put "on the air" by means of a standard television transmitter, which must be modified only to the extent necessary to assure performance within the reduced tolerance limits required by the color signal. (Since the color signal places more information in the channel than a black-and-white signal, the requirements for frequency response, amplitude linearity, and uniformity of delay time are more strict.)

The basic operations performed in a compatible color receiver are shown in Fig. 27. The antenna, RF tuner, IF strip, and second detector serve the same functions as the corresponding components of a black-and-white receiver. The sound signal may be obtained from a separate IF amplifier, or it may be obtained from the output of the second detector by using the well-known "intercarrier sound" principle. The video signal obtained from the second detector of the receiver is, for all practical purposes, the same signal that left the color

television studio. The receiver up to this point is no different from a black-and-white receiver except that the tolerance limits on performance are somewhat tighter.

The signal from the second detector is utilized in four circuit branches. One circuit branch directs the complete signal toward the color kinescope, where it is used to control luminance by being applied to all kinescope guns in equal proportions. In the second circuit branch, a band-pass filter separates the high-frequency components of the signal (roughly 2.0 to 4.1 MC) consisting mainly of the two-phase modulated subcarrier signal. This signal is applied to a pair of modulators which operate as synchronous detectors to recover the original I and Q signals. It should be noted that those frequency components of the luminance signal falling between about 2 and 4.1 MC are also applied to the modulators, and are heterodyned down to lower frequencies. These frequency components do not cause objectionable interference, however, because they are frequency-interlaced and tend to cancel out through the persistence of vision.

The remaining two circuit branches at the output of the second detector make use of the timing or synchronizing information in the signal. A conventional sync separator is used to produce the pulses needed to control the horizontal and vertical deflec-

tion circuits which are also conventional. The high voltage supply for the kinescope may be obtained either from a "fly-back" supply associated with the horizontal deflection circuit or from an independent RF power supply. Many color kinescopes require convergence signals to enable the scanning beams to coincide at the screen in all parts of the picture area; the waveforms required for this purpose are readily derived from the deflection circuits.

The final branch at the output of the second detector is the burst gate, which is turned "ON" only for a brief interval following each horizontal sync pulse by means of a pulse obtained from a multivibrator, which is in turn controlled by horizontal sync pulses. The separated bursts are amplified and compared with the output of a local oscillator in a phase detector. If there is a phase difference between the local signal and the bursts, an error voltage is developed by the phase detector. This error voltage restores the oscillator to the correct phase by means of a reactance tube connected in parallel with the oscillator's tuned circuit. This automatic-frequency-control circuit keeps the receiver oscillator in synchronism with the master subcarrier oscillator at the transmitter. The output of the oscillator provides the reference carriers for the two synchronous detectors; a 90° phase shifter is necessary to delay the phase of the Q modulator by 90° relative to the I modulator.

There is a "filter section" in a color receiver that is rather similar to the filter section of the transmitting equipment. The M, I, and Q signals must all be passed through filters in order to separate the desired signals from other frequency components which, if unimpeded, might cause spurious effects. The I and Q signals are passed through filters of nominally 1.5 and .5 MC bandwidth, respectively, just as at the transmitting end. A step-type characteristic is required for the I filter, as indicated by the sketch in Fig. 27, to compensate for the loss of one sideband for all frequency components above about .5 MC. A roll-off filter is desirable in the M channel to attenuate the subcarrier signal before it reaches the kinescope. The subcarrier would tend to dilute the colors on the screen if it were permitted to appear on the kinescope grids at full amplitude. Delay networks are needed to compensate for the different inherent delays of the three filters, as explained previously.

Following the filter section in the receiver there is a matrix section in which the M, I, and Q signals are cross-mixed to recreate the original R, G, B signals. The

R, G, B signals at the receiver are not identical to those at the transmitter because the higher frequency components are mixed, and are common to all three channels. This mixing is justifiable, because the eye cannot perceive the fine detail (conveyed by the high-frequency components) in color. There are many possible types of matrixing circuits; resistance mixers shown in Fig. 27 provide one simple and reliable approach. For ease of analysis, the matrix operations at the receiver may be considered in two stages. The I and Q signals are first cross-mixed to produce R-M, G-M, and B-M signals (note that *negative* I and Q signals are required in some cases), which are, in turn, added to M to produce R, G, and B.

In the output section of the receiver, the signals are amplified to the level necessary to drive the kinescope, and the DC component is restored. The image which appears on the color kinescope screen is a high-quality, full-color image of the scene before the color camera.

The writer hopes that this brief description of the RCA color television system has helped the reader to understand the major technical features of the system. We are, even now, on the threshold of an era in which color television is sure to find its place as an important broadcast service to the American public. The RCA system not

only provides excellent performance in its present state of development, but also has great potentialities for future improvement. As the basic principles of compatible color television become more thoroughly understood by engineers throughout the industry, we may expect the rapid development of improved kinescopes, cameras, studio equipment, and low-cost receivers. The day is not far distant when color television programs will be as commonplace as the black-and-white programs of today.

APPENDIX A

Mathematical Proof of the Two-Phase Modulation Technique

Let A and B represent two signals that vary independently with time, and let $W_c/2\pi$ represent the carrier frequency. Since doubly-balanced modulators produce a true product signal, the transmitted signal produced by the arrangement shown in Fig. 12 is equal to

$$A \cos W_c t + B \cos (W_c t + 90^\circ) \quad (1)$$

If A and B were expressed more specifically as functions of time, it would be seen that each of the above terms consists of a pair of sidebands. For example, let $A = a \cos W_A t$, where $W_A/2\pi$ is the modulation frequency. Then the expanded product $A \cos W_c t$ becomes:

$$A \cos W_c t = a \cos W_A t \cos W_c t = \frac{1}{2} a \cos (W_c + W_A) t + \frac{1}{2} a \cos (W_c - W_A) t \quad (2)$$

It happens, however, that we do need this expanded expression, but may continue the derivation with the equation in the form shown in (1) above.

To recover the A component, the entire transmitted signal is first multiplied by $\cos W_c t$ in a modulator to produce

$$A \cos^2 W_c t + B \cos (W_c t + 90^\circ) \cos W_c t = \frac{1}{2} A + \frac{1}{2} A \cos 2W_c t + \frac{1}{2} B \cos 90^\circ + \frac{1}{2} B \cos (2W_c t + 90^\circ) \quad (3)$$

When this output is filtered to remove the second harmonic components, the remaining signal is simply $\frac{1}{2} A$ (since $\cos 90^\circ = 0$). The factor of $\frac{1}{2}$ results from the fact that one-half of the signal energy is lost in the second-harmonic component in the process of detection, but this factor may be readily absorbed in the gain adjustments of the system.

Likewise, the output of a modulator which multiplies the transmitted signal by $\cos (W_c t + 90^\circ)$ is

$$A \cos W_c t \cos (W_c t + 90^\circ) + B \cos^2 (W_c t + 90^\circ) = \frac{1}{2} A \cos 90^\circ + \frac{1}{2} A \cos (2W_c t + 90^\circ) + \frac{1}{2} B + \frac{1}{2} B \cos (2W_c t + 180^\circ) \quad (4)$$

and when the second-harmonic components are removed, the remaining signal is $\frac{1}{2} B$.

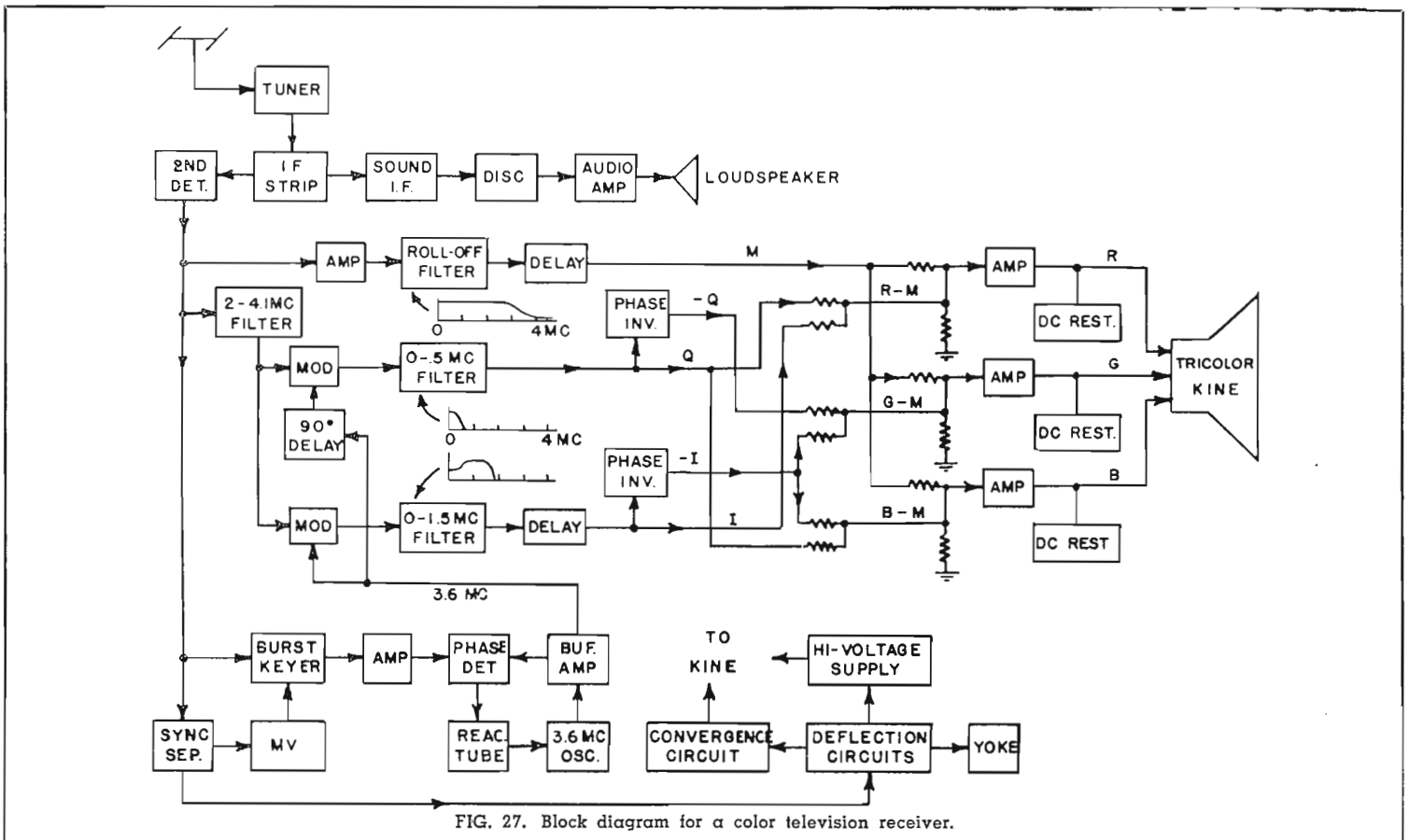

FIG. 27. Block diagram for a color television receiver.

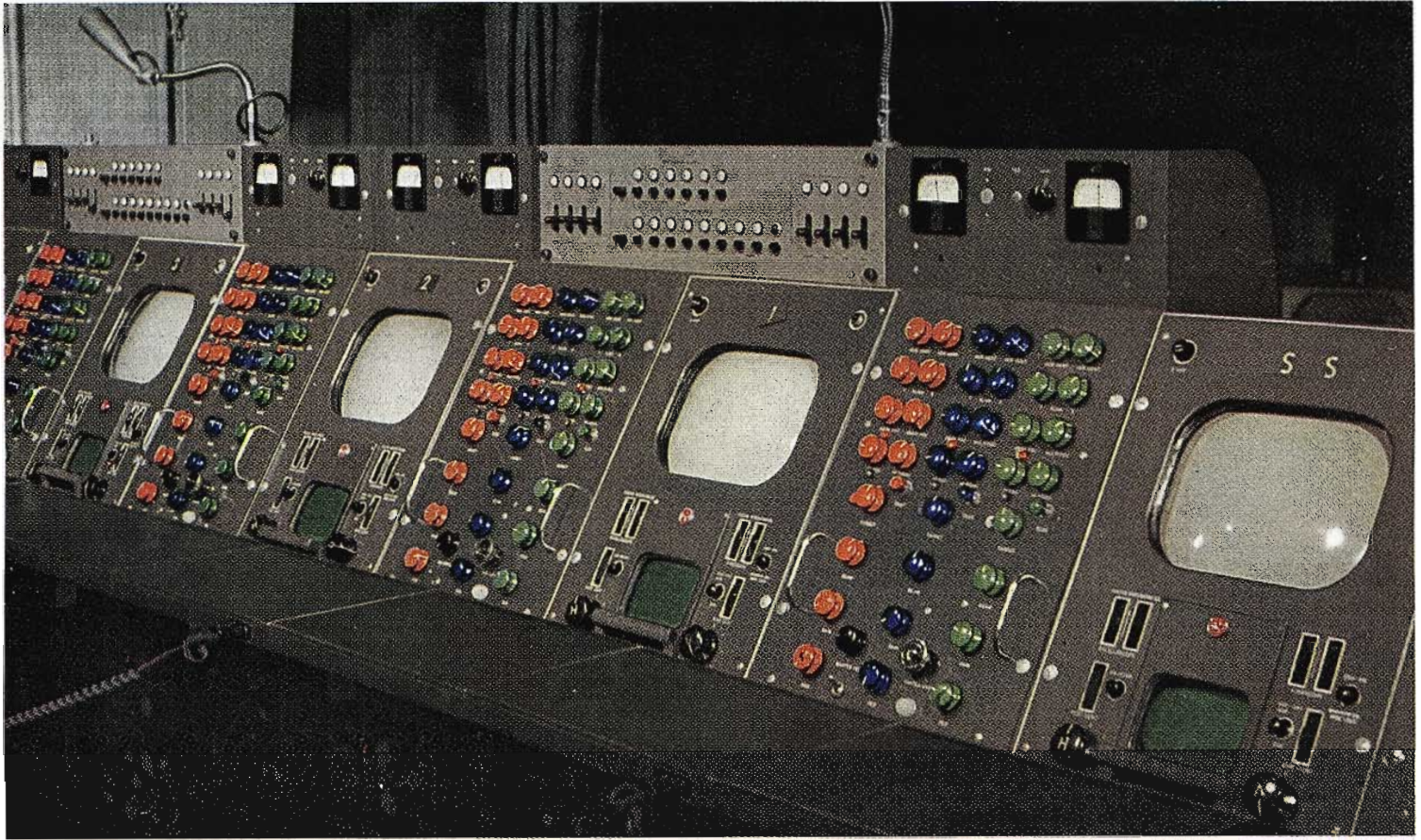

FIG. 1. Camera Control Console in the control room of NBC's Colonial Theatre Color Studio. Four RCA Color Cameras are controlled from this position. Each camera "chain" includes a camera control unit (the panels with a large number of knobs) and a modified Type TM-5B master monitor (used for monochrome monitoring).

HOW TO PLAN FOR COLOR

By
L. E. ANDERSON
 Supervisor,
 TV Studio Systems Engineering

Color poses a number of problems for TV broadcasters. The first question, of course, is when? And the answer is—that depends. It depends on the size of the market, income of the station, network affiliation, prestige position and possibly other factors. Some stations value highly their reputation for pioneering. Where their market and income affords it these stations probably will want to start color as soon as possible, regardless of network affiliation. However, it seems likely that most stations will gear their plans to the date the telephone company expects to provide them with a network color connection.

There are two reasons why this "connection date" seems particularly important. First, it is likely that whenever color programs are feasible in a particular area both advertisers and the public will demand that color be made available. Second, the availability of color network programs will make it possible for stations to provide color programs without the high cost

of local origination. In a way it's a fortunate situation. It means that just when the pressure for color begins to mount it also becomes feasible for the station to economically start in color. For most stations with network affiliations this seems to be the answer.

WHAT TO START WITH

Probably the question which is foremost in the minds of most broadcasters is the size and scope of the color operation that should be undertaken. Here again, the answer depends somewhat on the situation of the station as regards market, income, network affiliation and position. However, the answer is likely to depend more on the economics of the operation together with space considerations.

There are five general types of operation which may be considered. These are:

(1) *Telecasting only color programs received from the network.* All local originations—including station breaks—continue to be in monochrome only. Assuming that the existing transmitter can be used for color (all RCA-built TV Transmitters can be) this can be done very inexpensively. Only a few items of additional equipment are required and the very small amount of space needed for these will be available in any station. Almost every station with a network affiliation should be able to afford at least this type of operation.

(2) *Telecasting network color programs plus local station breaks and slide commercials in color.* This requires that the station have its own color slide camera. With this camera it can use color slides for station breaks and "spots", thereby avoiding the somewhat odious comparison that occurs when monochrome "breaks" are made between, or next to, color network programs. The necessary equipment is mod-

erately inexpensive and does not require an excessive amount of space. Most stations will find room for it without difficulty.

(3) *Telecasting network color programs plus locally originated slide and film programs in color.* This requires that the station have its own color slide camera and its own color film camera projector and associated equipment. All locally originated live programs will continue to be in monochrome. However, the station can greatly increase its percentage of color programs by adding color shorts, cartoons and such color feature films as may become available.

The extra space required (about equal to that used by the film setup of most existing stations) is not great. This type of operation also may be fitted into most stations without pushing out the walls.

(4) *Telecasting network color programs plus all types of local color programs including color live studio programs.* This, of course, requires one or more color studio cameras, and is relatively expensive. Providing live studio programs are not too elaborate, it is quite possible to do it in existing space. This means that the color camera will be used in the present monochrome studio. The existing control room may be too small for the added control equipment so that a new separate control room will be needed. This, of course, is preferable in any event so that color rehearsals can be held without disturbing monochrome operation. In many cases the

new control room can be provided by "double-decking" or "under-slinging" the present control room. In other cases a "clients' booth" or observation gallery is available and may be used.

(5) *Telecasting network programs in color plus large-scale local programs in color.* This, of course, is something that will come eventually for many stations. However, for the moment it represents a large expenditure, and is probably not one that many stations will undertake immediately. It would require either the addition of considerable studio and control room space, or the complete conversion of existing monochrome facilities to color. Stations which will originate color programs for a network will have to take some such step. However, most other stations are likely to wait a while for this.

HOW TO DO IT

The answers to "when" and "what" will be different for each station, and the decisions will be hard to make. However, once these questions are decided the "how" question can be answered quite explicitly.

RCA engineers, studying the likely course of color television development, have made up four detailed equipment plans. These plans correspond to the probable sequence of steps which many stations will follow in building up to a full scale color television operation. These steps are:

Step 1

Installation of equipment for telecasting network color programs.

Step 2

Addition of equipment for telecasting color slides.

Step 3

Addition of equipment for telecasting color films.

Step 4

Addition of equipment for telecasting color studio programs.

It will be noted that these steps are clearly defined. They permit a station to start on a modest basis with *Step 1* and to take additional steps whenever desirable. They have been carefully planned so that no unnecessary duplication or extra cost will be involved in doing this.

Each step is described in detail in the following pages. Included in these descriptions are lists of equipment. It should be noted that there are *six* groups of equipment. Four of these groups represent the particular equipment needed for each type of programming. The other two groups are the local color sync generating equipment group and the color test equipment group. The table below (Fig. 2) indicates the equipment groups ordinarily needed for each step. However, in some cases the Color Test Equipment and the Color Sync Generator may be ordered separately or in different steps. They are, therefore, listed separately here, as well as in RCA equipment proposal sheets.

FIG. 2. Equipment groupings for suggested sequence of steps in building up to full color programming.

	COLOR EQUIPMENT GROUPING	PROGRAM SOURCES PROVIDED OR USE INTENDED
STEP 1	Group "A" (Network Color Equipment)	Permits transmission of color program received from network source.
	Group "B" (Recommended Test Equipment)	Suggested for use by all stations in checking, controlling and maintaining a high quality picture.
STEP 2	Group "C" (Synchronizing Generator Equipment)	This is used and needed when station plans to "originate" its own color programs.
	Group "D" (Color Slide Camera Chain)	Permits origination of color pictures from slides.
STEP 3	Group "E" (Color Film Chain)	Permits the origination of color pictures from 16mm motion picture film.
STEP 4	Group "F" (Studio Camera Equipment)	Permits origination of live studio pictures in color.

STEP 1-Installation of Equipment for Telecasting of Network Color Programs (No Local Origination)

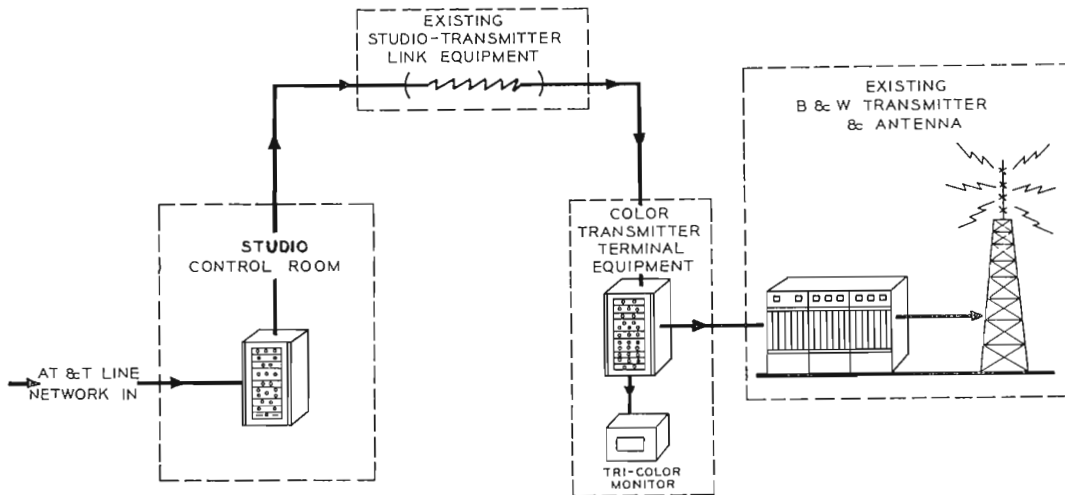

FIG. 3. Arrangement of equipment for telecasting network color programs. Color equipment consists of one rack (color stabilizing amplifier, power supply) in the studio control room and one rack (color stabilizing amplifier, distribution amplifier, correcting networks, power supplies) in the transmitter control room, plus a separately mounted tri-color monitor usually located at the transmitter.

STEP 1

Most existing TV stations will probably elect to start in color by installing first the equipment needed for telecasting color programs received from the network. Because of the foresightedness of television design engineers they will be able to do this very simply. Most stations need only make minor modifications in their present transmitters and add a relatively small amount of auxiliary equipment. The latter includes: (1) Video Input Equipment, (2) Phase Correcting Networks, (3) Monitoring Equipment, and (4) Test Equipment.

The arrangement of station equipment for network color telecasting is shown pictorially in Fig. 3. A list of the equipment required by an existing TV station in order to make such an installation is shown in the box at right. The functional arrangement of the color equipment items is shown in Fig. 4. The main features of this equipment arrangement are as follows:

TRANSMITTER MODIFICATION

All of the RCA Television Transmitters in use today were designed with color requirements in mind. However, the color standards, as finally adopted, require closer tolerances than were originally contemplated. For this reason minor circuit modifications will be necessary in some models. A kit of parts and detailed instructions will be made available. At the time these are installed the transmitter should be carefully readjusted. (RCA will furnish parts, and provide an engineer to install these parts, at no charge, for all post-war RCA TV Transmitters.)

Once the transmitter is adjusted for the stringent requirements of color television it will obviously also be in extra good adjustment for monochrome. All of the equipment arrangements described here assume that the same transmitter will be used for color and monochrome. The transmitter input is simply switched to the output of the monochrome terminal equipment or the output of the color terminal equipment, according to which type program is to be aired. Where a microwave STL is used between studio and transmitter this may also be used for both systems although some modifications may be necessary to provide best operation for color.

VIDEO INPUT EQUIPMENT

The video input, or terminal equipment used for color should be kept separate from that used for monochrome. There are some monochrome video units which can be modified for color. However, if these units were to be used interchangeably without modification it would be necessary to provide some means of switching over the circuits every time the type of program changed. At the present time this does not seem practical. Therefore, all the systems described hereafter are based on the use of a completely separate video setup for color. If there is any question concerning the integration of an existing monochrome station with color system, it is suggested that a competent Systems Engineer be consulted.

The video input equipment for a station planning "network color only" is very

simple. It consists essentially of two color stabilizing amplifiers, a distribution amplifier and necessary power supplies. This assumes that the network line is brought into a studio location which is remote from the transmitter. A color stabilizing amplifier is used at the studio to "clean up" the received signal, just as in monochrome transmission. This stabilizing amplifier may be a modified TA-5B, C, or D unit. The signal is fed from this amplifier to the STL. At the transmitter another color stabilizing amplifier Type TA-7A is used, and this is placed after the correcting networks as shown in Fig. 4.

The color stabilizing amplifier differs from the Type TA-5A-D (Monochrome) Stabilizing Amplifier chiefly in the fact that it is designed to pass the sub-carrier "burst" (which is inserted on the "back porch" of the sync signal) without altering its phase or magnitude. In addition, the color stabilizing amplifier incorporates a non-linear amplifier which is used to adjust the overall system linearity.

CORRECTING NETWORKS

In order to comply with the FCC standards two phase correcting networks must be installed in the input line to the transmitter as shown in Fig. 2. These provide a calculated amount of phase pre-distortion to make up for phase distortion in the rest of the system. The low-frequency network compensates for the phase shift in the vestigial side-band filter. The high-frequency network compensates for

FIG. 4. Block diagram of the equipment required for telecasting network color programs. Blocks in the upper half of the diagram (above the broken line) represent equipment units normally required for this type of operation (Equipment Group A). Blocks in lower half represent test equipment considered essential for proper operation (Equipment Group B). The Color Bar Generator is required only when local origination of color programs is planned.

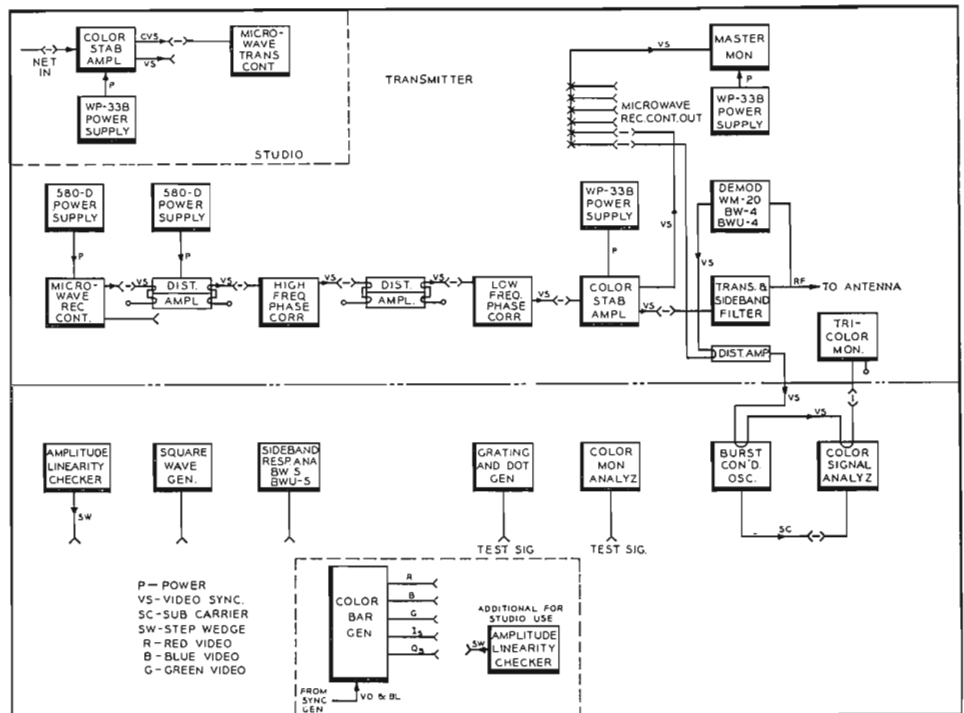

the deficiency in high-frequency response of the receiver. A more detailed explanation is given on Pages 35 and 36.

MONITORING EQUIPMENT

In order to be able to visually monitor the picture transmitted, a Tri-Color Monitor is required. A monitor of this type is described in the article on Page 72.

The Tri-Color Monitor must be fed from a high-quality demodulator. Most stations presently have either a BW-4A or BWU-4A Demodulator. With minor modifications any of these may be used. A Demodulator Conversion Kit is available for making the necessary changes.

Fig. 4 indicates the use of a standard monochrome monitor (in addition to the Tri-Color Monitor). This unit is not listed in the "required equipment" because the monitor which is a part of the standard transmitter control console can be used for this purpose.

TEST EQUIPMENT

Every Station Manager and Broadcast Engineer recognizes the need for, and the value of, proper test equipment. The needs of television led to the development of numerous new test equipment units. Color television requires still more test equipment—most of it of new and unique design. Moreover, the rigid performance specifications for transmitters and other

color TV equipment make the use of this equipment almost a necessity.

A relatively simple installation may require almost as many different test equipment units as the largest station. For this reason a standard list of "recommended test equipment" has been made up and it is suggested that every station purchase this equipment as early as possible. This list is shown in the box at the right below, and the various units are indicated in the

lower half of Fig. 4. The separate items are described and their use explained in the article "RCA Test Equipment for Color TV", Page 76.

All of this test equipment can be profitably used in *Step 1*. In addition, a Color Bar Generator can be used when a Color Sync Generator is available. Its principal use is in conjunction with a Colorplexer to provide a Color Bar Test Pattern Output.

GROUP A	
Color Network Operating Equipment	
QTY.	DESCRIPTION
*2	Color Stabilizing Amplifier, Type TA-7A
2	580-D Power Supply
1	Tri-Color Monitor, including Kine, Type TM-10A
1	Low Frequency Phase Correction Network, MI-34025
1	High Frequency Phase Correction Network, MI-34026
1	Color Correction Kit for Demodulator
1	TA-1A Distribution Amplifier
3	580-D Power Supply
2	Cabinet Rack with Front and Rear Doors, MI-30951-C84
1	Video Jack Panel, MI-26245
10	Video Jack Plugs, MI-19118
5	Video Jack Cords, MI-7233-4
1	57-D Switch and Fuse Panel
* One of these can be a modified TA-5B, C, or D.	

GROUP B	
Color Test Equipment	
QTY.	DESCRIPTION
1	Color Monitoring Analyzer, MI-34022, Type WA-2A
1	Grating and Dot Generator, MI-30003-B, Type WA-3B
1	Linearity Checker, MI-34017, WA-7A
1	Color Signal Analyzer, MI-34016, Type WA-6A
1	Burst Controlled Oscillator, MI-34023, Type WA-4A
1	Test Meter
1	TO-524-D Television Oscilloscope and Type 500 Scope-Mobile
NOTE: One of the following units is assumed to be part of station's existing Test Equipment; add one to Group B if it is not.	
1	BW-5A Side Band Response Analyzer Ch. 2-13
1	BWU-5A Side Band Response Analyzer Ch. 14-83

STEP 2-Addition of Equipment For Telecasting Color Slides From Your Own Studios

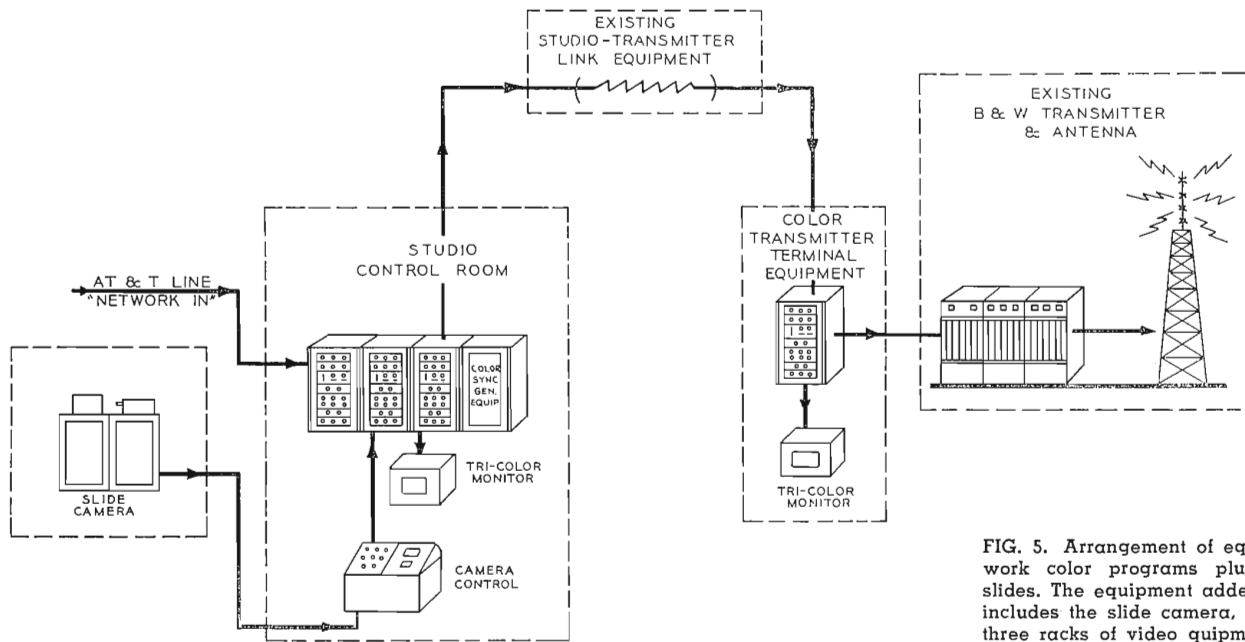

FIG. 5. Arrangement of equipment for telecasting network color programs plus locally originated color slides. The equipment added (to that shown in Step 1) includes the slide camera, the camera control console, three racks of video equipment and a tri-color monitor.

STEP 2

For most stations, the second step in color will be the addition of equipment allowing them to telecast their own color slides. This will enable these stations to make station breaks in color (definitely desirable when telecasting network programs in color) and to sell color "spots" to local and national advertisers. Color Slide programs are relatively easy to make up because 35mm color transparencies can be used "as is" for color slides.

Providing facilities for color slide programming involves the addition of considerable equipment. This is because not only the slide pickup equipment itself, but also local color sync generating equipment, must be provided in this step. Multiplexing and monitoring must also be provided. Thus the complete equipment to be added in Step 2 includes four groupings, viz., (1) Local color sync generating equipment, (2) Color Slide Camera, (3) Colorplexer, and (4) Color Monitor.

The arrangement of station equipment for network color telecasting plus local color slide programming is shown pictorially in Fig. 5. The equipment items which must be added to a simple Color TV Station (such as described in Step 1) in order to make it into a "Step 2" station are listed in the box at right. The functional arrangement of this additional equipment is indicated in Fig. 6 and Fig. 7.

COLOR SYNC GENERATOR EQUIPMENT

A station which telecasts only network color (Step 1) does not require a local Sync Generator because the color signal received over the network line is a complete composite signal (i.e., it includes all necessary sync pulses as well as picture signals). This composite signal can be "cleaned up" in a color stabilizing amplifier and fed to the transmitter as described in Step 1.

However, when a station decides to start local color programming, (no matter how simple) the color sync signals, as well as the color picture signals, must be generated locally. Thus before a station can start color slide programming it must install its own color sync generating equipment.

Color sync signals differ from monochrome sync signals in one major respect. This is that they have a "burst" of sub-carrier frequency (3.6 mc) superimposed on the "back porch" of the horizontal sync pulse. This "burst" is supplied by a Burst Flag Generator, as shown in Fig. 6.

A minor difference in color sync signals is that they are controlled by the sub-carrier oscillator (rather than the 60-cycle supply). This thermostatically controlled 3.6 mc oscillator is contained in a new unit, the Color Frequency Standard (Fig. 6). Divider circuits fed from this oscillator

develop a 31.5 kc signal which is used to drive the sync generator.

The Sync Generator is a standard TG-1A, slightly modified to accept 31.5 kc at the "External" drive input. With this modification the TG-1A can be used for monochrome or color, as desired. If the station has a spare TG-1A this can be used for the color setup. It is not considered good practice to use one TG-1A for both setups, since changing over from

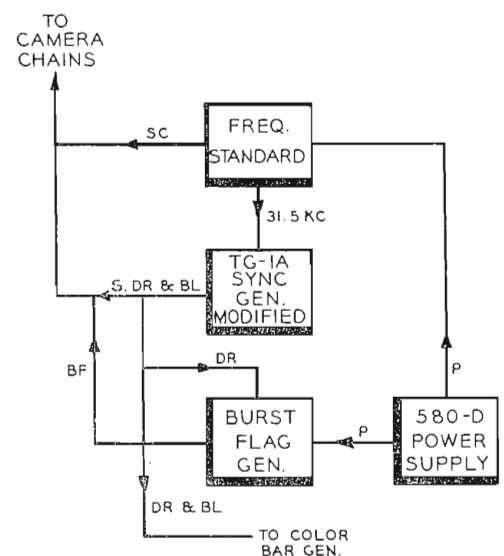
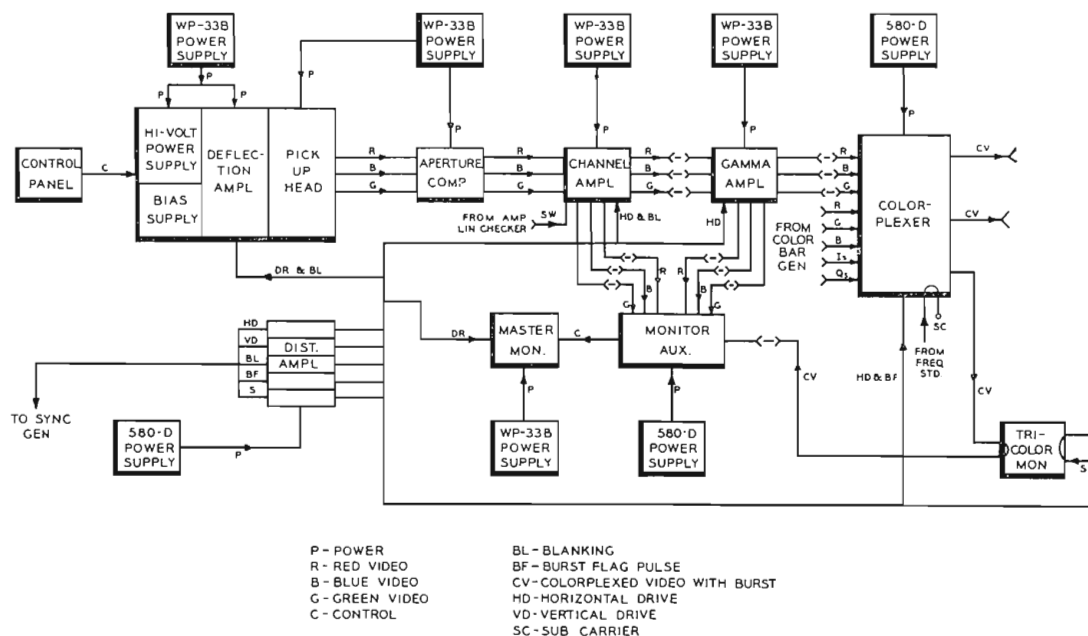

FIG. 6. Functional arrangement of equipment units for producing color sync signals locally (Equipment Group C).

FIG. 7. Block diagram of the equipment included in a "color slide camera chain" (Equipment Group D). This equipment, plus the local color sync generating equipment shown in Fig. 6, must be used (in addition to the equipment shown in Step 1) when it is desired to telecast color slides from the local studios.



monochrome to color, or vice versa, would cause a break in the sync signals fed the receiver. However, both station sync generators can be modified, thus providing an emergency spare for either type operation.

COLOR SLIDE CAMERA

The main equipment added in *Step 2* is the Color Slide Camera Chain. This consists of a flying spot scanner employing a 27KV Kinescope as an illuminating source, a three-color pickup unit, amplifiers, correcting circuits, monitoring and power supply units together with necessary controls. The functional arrangement of equipment units is shown in Fig. 7.

The scanner proper and pickup heads are mounted on top of a table formed by two 42-inch cabinet racks. Mounted in the latter are the high-voltage deflecting circuits for the kinescope, aperture compensator and the channel amplifiers. Other equipment units and power supplies are mounted in three standard cabinet racks. A detailed description of this equipment is given in the article "RCA Color Slide Camera" on Page 52.

COLORPLEXER

The output of the Color Slide Camera consists of *simultaneous* red, green and blue picture signals. Before these can be fed to the transmitter they must be combined with the sub-carrier into a composite color video signal. The unit which performs this important function is called a Colorplexer. The Colorplexer performs two op-

erations: (1) it cross-mixes the R, G, and B signals to form the luminance (or monochrome) signal and the two chrominance signals and (2) it multiplexes these signals with the sub-carrier to produce a composite color signal suitable for feeding the transmitter. The necessity for doing this is explained in the article "RCA Color TV System" on Page 6. The Colorplexer itself is described in detail in the article "RCA Colorplexer" on Page 48.

TRI-COLOR MONITOR

In order to monitor the Slide Camera operation both monochrome and color monitors are desirable. The monochrome monitor is necessary in order to properly set the separate R, G, and B channels. This is a standard unit provided with an auxiliary switching panel. A tri-color monitor is essential in checking the overall output of the slide system. This unit is described in the article "RCA Color Monitor" on Page 72.

GROUP C	
Sync Generator Equipment	
QTY.	DESCRIPTION
1	Color Frequency Standard, MI-40201
1	Burst Flag Generator, MI-40202
1	Modification Kit for TG-1A Sync Generator, MI-40405
1	580-D Power Supply
1	TG-1A Studio Sync Generator
1	Cabinet Rack with Front and Rear Doors, MI-30951-C84

GROUP D	
Color Slide Camera Chain, Type TK-4A	
QTY.	DESCRIPTION
1	Slide Camera Pickup Head and Pre-amplifier, MI-40804, including Iris Control, Optics, Slide Holder, and Photocells
1	Monitor Auxiliary, MI-40513
1	Slide Camera Remote Control Panel, MI-40812
1	Slide Camera Table Top, Kine Mounting, Racks and Kinescope, MI-40806
1	Deflection Chassis, MI-40808
1	27 KV Power Supply, MI-40809
1	Channel Amplifier, MI-40810
1	Aperture Compensator, MI-40503
1	Bias Supply, MI-40508
1	Slide Camera Gamma Amplifier, MI-40506
1	Colorplexer, TX-1A
1	Tri-Color Monitor, including Kine, Type TM-10A
1	Monochrome Control Monitor with Type TM-6B (modified) CRO and Kine, MI-40512
10	Video Jack Cords, MI-7233-4
14	Video Jack Plugs, MI-19118
3	580-D Power Supply
5	WP-33B Power Supply
2	Video Jack Panels, MI-26244
1	Monitor Blower, MI-26579-B
1	TA-1A Distribution Amplifier
3	Cabinet Rack with Front and Rear Doors, MI-30951-C84
2	Console Housings, MI-26266-B

STEP 3-Addition of Equipment For Telecasting 16mm Color Films From Your Own Studios

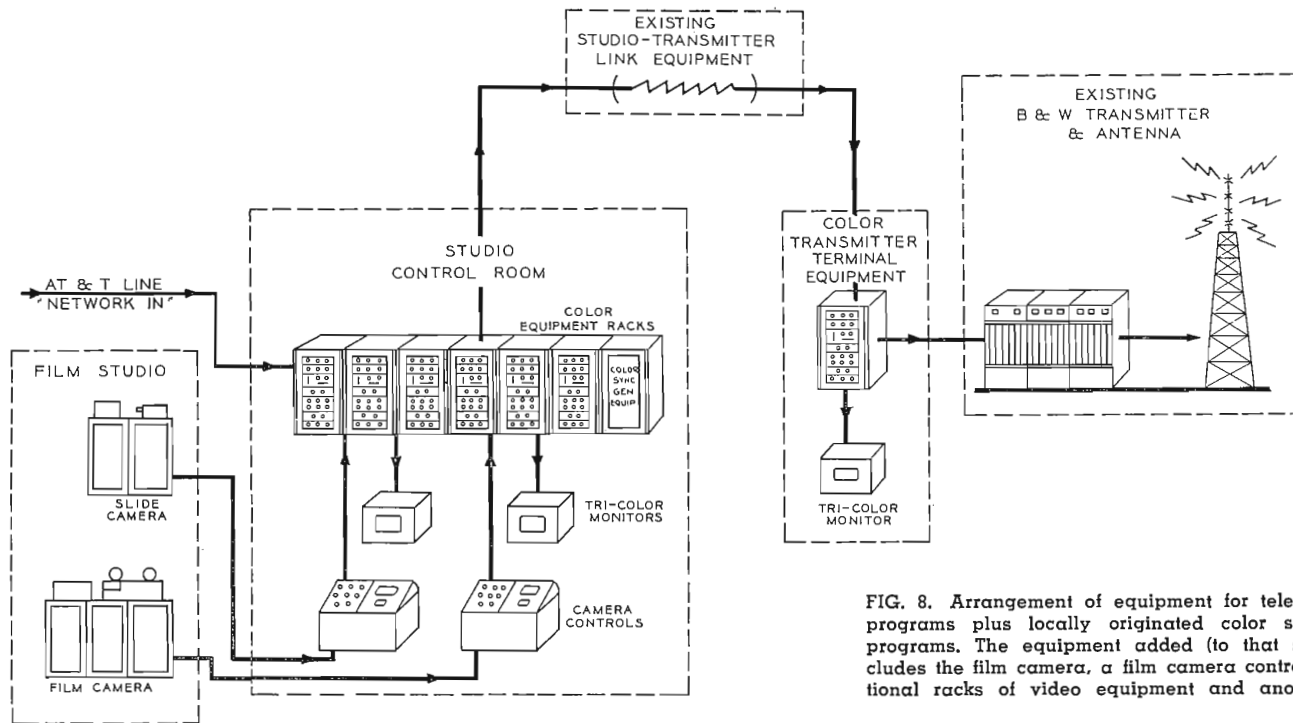

FIG. 8. Arrangement of equipment for telecasting network color programs plus locally originated color slides and color film programs. The equipment added (to that shown in Step 2) includes the film camera, a film camera control console, three additional racks of video equipment and another tri-color monitor.

STEP 3

The third step in building the complete color television station is the addition of equipment for handling 16mm color films. One of the big attractions of color is the much greater interest it will lend to product advertising. At the present time many "commercials" are supplied on short film strips. With the advent of color this trend will undoubtedly increase. In addition, there are many short subjects that are available in 16mm Color Film which program departments will be anxious to use.

The equipment for televising color film does not require a large amount of additional space and operating cost is reasonable. Thus it represents a much smaller and less expensive step than installation of live studio color. In fact, it is considered likely that the addition of Step 3 equipment will give many stations all the color equipment they will want for several years to come. The arrangement of such a station is indicated pictorially in Fig. 8. A list of the equipment items which must be added (in order to make a Step 2 station into a Step 3 station) is shown in the box on Page 27. The functional arrangement of the added equipment units is shown in Fig. 9.

As is usually the case (in monochrome or color) it is not enough to just add a projector and camera in order to obtain the extra facilities of Step 3. The color film

equipment is more complex than monochrome equipment and therefore requires more associated equipment. The complete film equipment includes main groupings which are (1) Slide Camera, (2) Fast Pull-Down Projector, (3) Camera, (4) Auxiliary Equipment, (5) Colorplexer, and (6) Monitoring equipment. A brief description of these follows. Additional information is given in the article "RCA Color Film Equipment" on Page 58.

COLOR FILM CAMERA

In the RCA Color Film Equipment the illuminating source is a kinescope scanning tube identical to that used in the RCA Color Slide Camera which was a part of the equipment added in Step 2. This scanner, which consists of a 27KV Kinescope with suitable deflecting circuits, is described in the article "RCA Color Slide Camera" on Page 52. The use of flying spot principle solves the light problem and provides a method of reproduction which is capable of high resolution and inherently perfect registration of the three color signals.

FAST PULL-DOWN PROJECTOR

The "projector" used in the RCA Color Film Equipment is completely different from anything used in monochrome. Although it has a similar (3-2) intermittent (to convert 24 frames to 30 frames) it

actually pulls the film down some four times faster than conventional machines. This speed makes it possible to complete the film travel during the vertical blanking interval. Thus the light can be on the film during the regular framing interval and there is no need for image "storage" as in present monochrome film cameras.

Since the color system is not tied to the 60-cycle supply the projector is supplied with driving power by a 500-watt amplifier which is driven by a converter circuit tied into the main sync generator. This keeps the pull-down cycle in time with the vertical scanning cycle.

FILM CAMERA

The "camera" consists of a system of dichroic mirrors which break up the light beam into three color beams and direct these beams onto three photocells. The physical arrangement of the optical system and photocells is very similar to that of the Slide Camera.

The flying spot camera, projector and camera units are mounted on a table formed by the tops of three 42-inch equipment racks. The deflection circuits and correcting networks are in the 42-inch racks. Motor driving amplifiers, Gamma Amplifier, Aperture Compensator and channel amplifiers are mounted in the main equipment racks in the Studio control room.

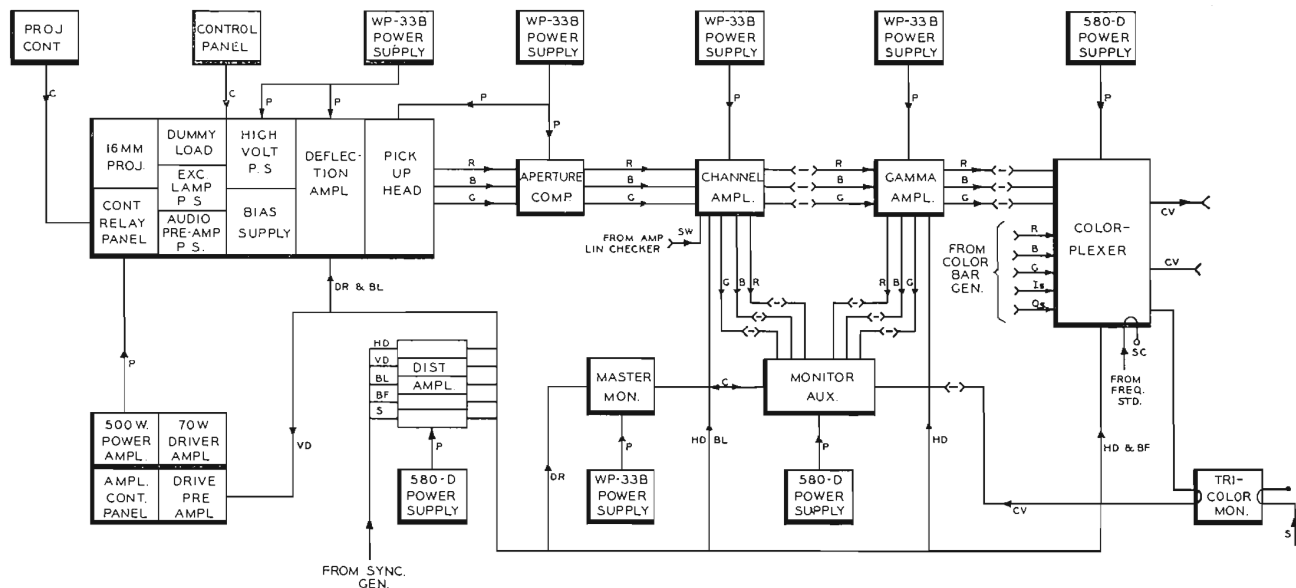

FIG. 9. Block diagram of the equipment included in a "color film chain" (Equipment Group E). This equipment must be used (in addition to the equipment shown in Steps 1 and 2) when it is desired to telecast color films as well as color slides and color network programs.

P-POWER
R-RED VIDEO
B-BLUE VIDEO
G-GREEN VIDEO
C-CONTROL
SW-STEPWEDGE
BL-BLANKING
BF-BURST FLAG PULSE
CV-COLORPLEXED VIDEO WITH BURST
HD-HORIZONTAL DRIVE
VD-VERTICAL DRIVE
SC-SUB CARRIER

AUXILIARY EQUIPMENT

In the video part of the film chain the camera is followed by several compensating and control units. These include (a) an Aperture Compensator which compensates for the effect of beam size by adding a certain amount of high frequency boost, (b) a Channel Amplifier (contains three separate channels) in which blanking is added, and (c) a Gamma Amplifier which provides linearity compensation to partially make up for the non-linearity which occurs in the receiver (or monitor) kinescope. All three of these units are similar to those used in the same Color Slide Camera.

COLORPLEXER

The output of the Color Film Camera (like that of the Slide and Studio Cameras) consists of simultaneous R, G and B signals. Before these can be fed to the transmitter line (or to a single channel switcher they must be matrixed (cross-mixed) and multiplexed with the sub-carrier. This is accomplished by an RCA Colorplexer—just as was done with the output of the Slide Camera in Step 2.

It should be noted that it is entirely possible for a station to operate with just one Colorplexer. In this case a 3-channel switcher would be used to connect the output of the camera in use to the Colorplexer. However, in this case only the "on-air" camera output could be monitored in color. Precepts of good practice indicate the desirability of having each studio (and possibly each camera) equipped with its

own Colorplexer. This allows the studio to be used as an integral unit for rehearsals or film previews.

MONITORING EQUIPMENT

Both monochrome and tri-color monitoring should be available for best results. The monochrome setup consists of an auxiliary switching panel and a standard monochrome monitor. The R, G or B pictures (or combination of them) at the output of either the Channel Amplifier or the Gamma Amplifier may be selected for observation. This allows each channel to be separately adjusted for optimum results. Tri-color monitoring is accomplished with an RCA Color Monitor of the type previously referred to as a part of the equipment layouts in Steps 1 and 2, described in the article "RCA Color Monitor" on Page 72.

PHYSICAL ARRANGEMENT

As previously noted, the major parts of this equipment (scanner, projector, camera) are mounted as an integral assembly on a table formed by the top of three 42-inch racks. These racks contain deflection circuits, high-voltage power supply, etc. Other auxiliary units and the numerous power supplies (standard 33-B's and 580-D's) will mount in standard size cabinet racks located in any convenient place. The monochrome monitor and associated control panel are designed to mount in two standard RCA Console Housings. The Color Monitor (see illustration Fig. 1, Page 72) is finished on four sides so that it may be mounted in

the most convenient position for operators and directors to see (for example, suspended above the control room window).

GROUP E	
Color Film Chain, Type TK-25A	
QTY.	DESCRIPTION
1	Projector, 16mm Fast Pull Down, including Sound Head and Accessory Audio and Mechanical Items
1	Projector Camera Preamplifier, MI-40807
1	Projector Camera Control Panel, MI-40814
1	Projector Table Top, Kine Mounting, Racks, and Kinescope, MI-40821
1	Deflection Chassis, MI-40808
1	27 KV Power Supply, MI-40809
1	Channel Amplifier, MI-40810
1	Projection Camera Gamma Amplifier, MI-40506
1	Aperture Compensator, MI-40503
1	Bias Supply, MI-40508
1	Colorplexer, Type TX-1A
1	Tri-Color Monitor, including Kine, TM-10A
1	Monitor Auxiliary, MI-40513
1	Monochrome Control Monitor with Kine and CRO, Type TM-6B (modified), MI-40512
10	Video Jack Cords, MI-7233-4
14	Video Jack Plugs, MI-19118
3	580-D Power Supply
5	WP-33B Power Supply
2	Video Jack Panel, MI-26244
1	Monitor Blower, MI-26579-B
1	TA-1A Distribution Amplifier
3	Cabinet Racks with Doors, MI-30951-C84
2	Console Housings, MI-26266-B

STEP 4 - Addition of Equipment For Telecasting Live Color Programs Originated In Your Own Studios

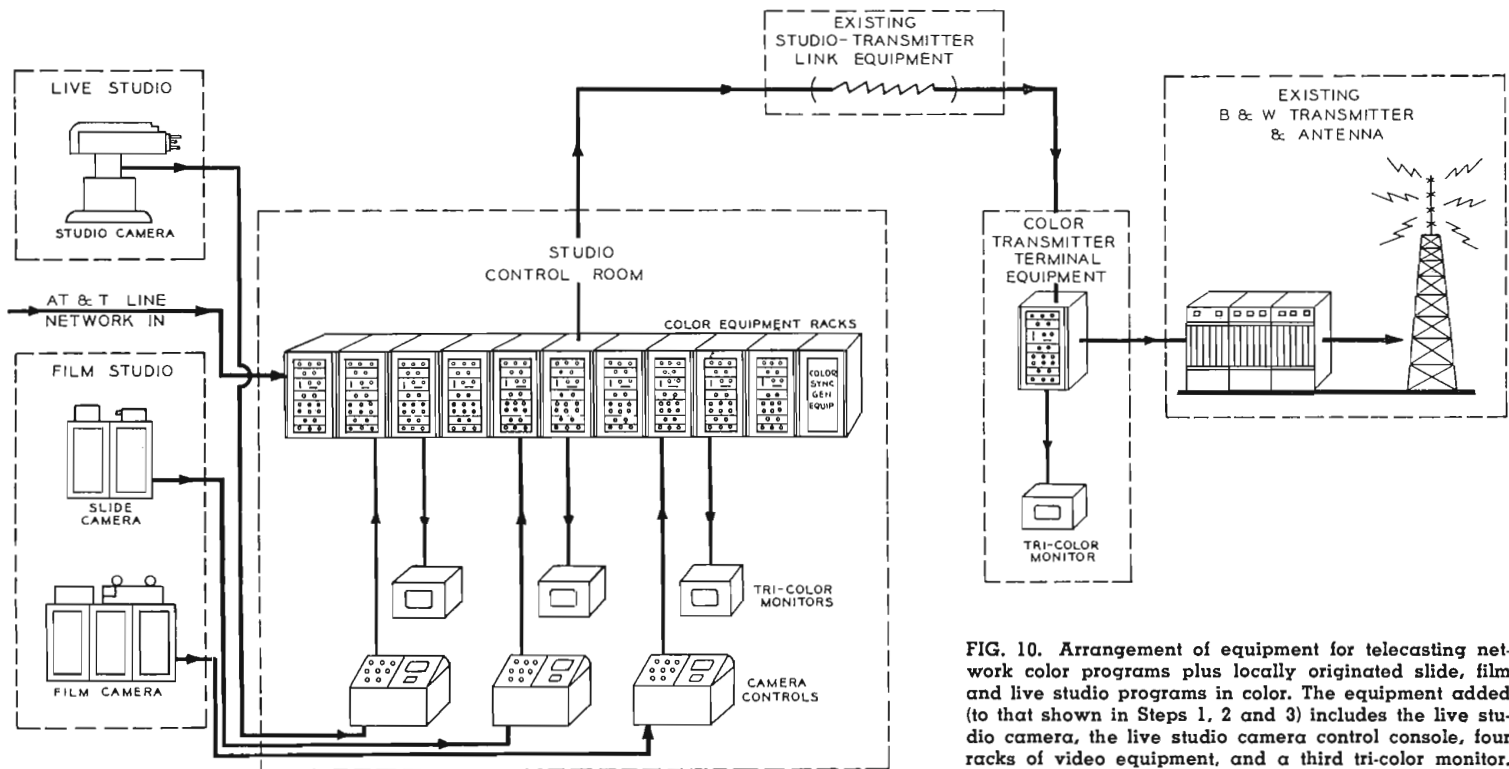

FIG. 10. Arrangement of equipment for telecasting network color programs plus locally originated slide, film and live studio programs in color. The equipment added (to that shown in Steps 1, 2 and 3) includes the live studio camera, the live studio camera control console, four racks of video equipment, and a third tri-color monitor.

STEP 4

Eventually, nearly every station will want to telecast its own live color programs. There is an irresistible attraction in local pickups that no station can long ignore.

It is true, however, that many stations do not need elaborate live studio setups. The equipment arrangement in *Step 4* provides the very minimum in live program facilities, viz., a single camera. Addition of the equipment makes it possible to program from four sources, i.e., network, slides, film and live studio. The arrangement of a station of this type is shown pictorially in Fig. 10.

The equipment items included in our complete Color Studio Camera Chain are listed in the box on Page 29. The functional arrangement of these units is indicated in the diagram of Fig. 11. It should be noted that this camera chain is identical in every respect with those used in the largest multiple camera setups. Thus the station starting with just one studio camera is nevertheless assured of the very highest quality, and has assurance of being

able to add more cameras as desired without obsolescence of any previously purchased equipment.

The complete Color Studio Camera Chain consists of (a) three-tube camera, (b) viewfinder, (c) camera control equipment, (d) auxiliary equipment, (e) Colorplexer, and (f) monitoring equipment. This equipment is described in detail in the article "RCA Color Camera" on Page 62.

THREE-TUBE CAMERA

The RCA Color Camera employs three image orthicons. An optical system using dichroic mirrors splits the light up into red, green and blue components and focuses these on the mosaics of the three picture tubes.

As in the standard monochrome camera, the optical system, the deflection circuits, the pickup tubes and the preamplifiers are located in the three-tube color camera. The turret on the camera is designed to accommodate four standard television lenses. The optical system provides images on the three image orthicon tubes. A selsyn-operated

iris control is also a part of the optical system and serves as a gain control as well. The plug-in video preamplifiers and the deflection circuits are arranged for ease-in-operation and maintenance.

VIEWFINDER

The Viewfinder provides the cameraman with a high quality monochrome picture on a seven-inch kinescope for checking picture composition and optical focus during operation. The camera registration may be checked at the camera position since it is possible to view the primary color picture signals, both separately or in various combinations on the Viewfinder.

CAMERA CONTROL EQUIPMENT

The Camera Control Equipment is housed in a cabinet rack and a console housing. In the cabinet rack are the aperture compensation amplifiers, the channel amplifiers for adding blanking to the video signals, gamma correction amplifiers, and a cable junction chassis to which cables from the camera, console and rack equipment are connected. A shading generator and controls for the three image orthicon

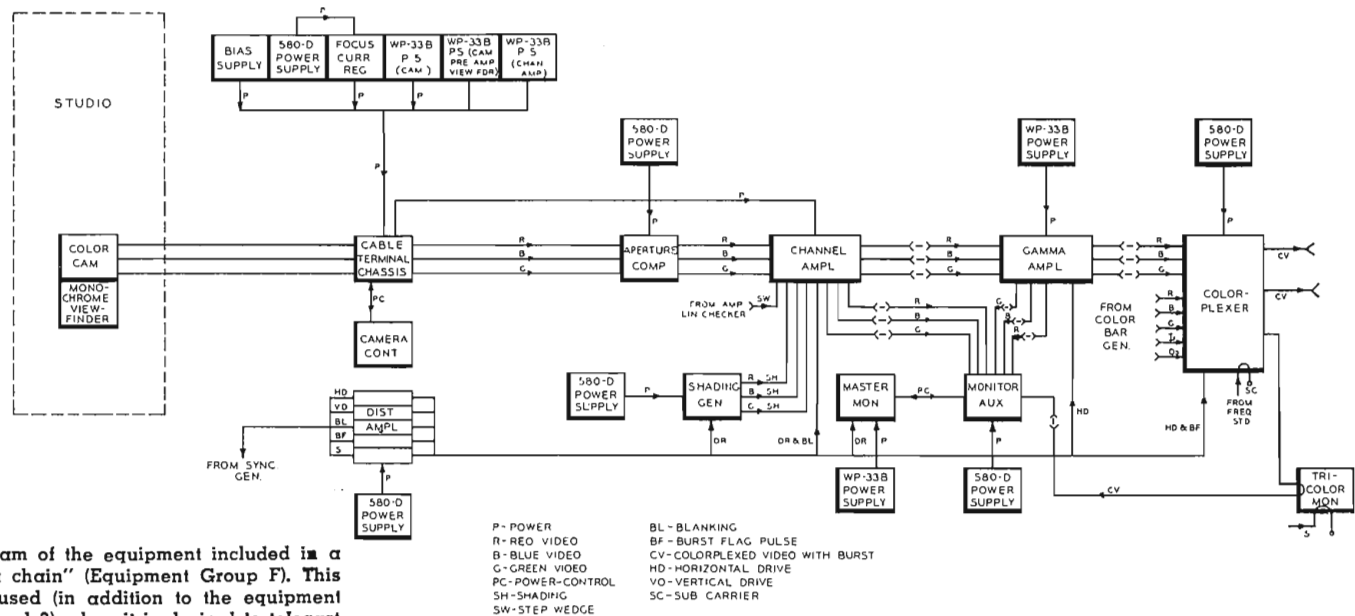

FIG. 11. Block diagram of the equipment included in a "color studio camera chain" (Equipment Group F). This equipment must be used (in addition to the equipment shown in Steps 1, 2 and 3) when it is desired to telecast local live studio programs, as well as slides, films and network programs, in color.

tubes are located in one console housing. An adjacent console housing contains the monochrome master monitor and auxiliary equipment.

AUXILIARY EQUIPMENT

The auxiliary equipment used with the studio chain is almost identical to that used with the slide and film chain. The three-signal output of the camera proper is fed through an Aperture Compensator, a Channel Amplifier and a Gamma Amplifier as in the other chains. One added element is a Shading Generator which is used to correct for any non-uniformity in the scanned area of the mosaic (just as in monochrome).

COLORPLEXER

The R, G and B signal outputs of the studio color camera are fed into a Colorplexer, just as are the outputs of the slide and film cameras. As noted previously it is desirable to have a Colorplexer for each studio, and preferably one for each camera. By means of the Color Bar Generator, the Colorplexer can be adjusted for perfect multiplexing. Using this adjustment as a reference, and Color Monitor for observing, the elements of the camera chain can be lined up for the best possible picture.

MONITORING EQUIPMENT

The standard arrangement of both monochrome and color monitoring is indicated. The monochrome monitor which consists of a standard master monitor with an auxiliary switching panel is especially

important. The Master Monitor, in conjunction with the monitor auxiliary equipment, permits the checking of levels of the individual color signals both before and after gamma correction is applied. It is also possible to check the camera registration by observing various combinations of the primary signals on this monitor.

The Color Monitor, which is also the same as that used with the slide and film chains is described in detail in the article "RCA Color Monitor" on Page 72.

PHYSICAL ARRANGEMENT

The camera proper, with attached viewfinder can be mounted on the TD-1A Studio Pedestal used for monochrome cameras. The weight of the camera is carefully balanced on a new heavy-duty spring-type friction-head. This enables it to be panned either way with little more difficulty than a monochrome camera.

The monochrome master monitor and camera control panel are designed to mount in two standard RCA Console Housings. These can conveniently be lined up with the similar console housings of other camera control units. The auxiliary units, Colorplexer, and power supplies mount in three standard equipment racks.

The Color Monitor is a separate unit (see illustration Fig. 1, Page 72) so designed that it can be mounted in any of a number of ways. Since both camera control operators and directors will need to see this monitor it must be placed at some vantage point. This will vary according to the layout of the studio control room.

GROUP F	
Color Studio Camera Chain, TK-40A	
QTY.	DESCRIPTION
1	Color Camera less Image Orthicons, MI-40500
1	Viewfinder & Hood MI-40501/40502
1	Camera Channel Amplifier, MI-40504
1	Cable Terminal Chassis, MI-40507
1	Focus Current Regulator, MI-40509
1	Camera Control, MI-40510
1	Shading Generator, MI-40511
1	Monitor Auxiliary, MI-40513
1	Set of Special Cables, MI-40803-2
1	Monochrome Control Monitor with Kine and CRO, Type TM-6B (modified), MI-40512
1	Aperture Compensator, MI-40503
1	Bias Supply, MI-40508
1	Camera Gamma Amplifier, MI-40505
1	Colorplexer, Type TX-1A
1	Tri-Color Monitor, TM-10A
6	580-D Power Supply
5	WP-33B Power Supply
2	Console Housings, MI-26266-B
1	Lens 50mm., MI-26550-1
1	Lens 90mm., MI-26550-2
1	Lens 135mm., MI-26550-3
1	Monitor Blower, MI-26579-B
3	Camera Cable, 50 ft., MI-26725-A5
1	Cradle-Type Pan and Tilt Head, MI-40824
1	Heavy Duty Pedestal, MI-50826
1	Set of Three Matched Image orthicons (Type 1854)
4	Cabinet Racks & Doors MI-30951-C84
4	Video Jack Cords, MI-7233-4
14	Video Jack Plugs, MI-19118
1	Video Jack Panel, MI-26244
1	Distribution Amplifier, Type TA-1A
2	Headsets, MI-26583-1

FACILITIES FOR COLOR PROGRAM SWITCHING

The description on preceding pages has indicated how unit equipment groupings may be added step-by-step to increase the color video facilities of a TV station. Further increases can be made by adding additional film, slide or studio cameras, as desired. In most cases it will be necessary to add a complete equipment grouping as shown in original list of equipment (i.e., Group E when another film camera is added; Group F when another studio camera is added, etc.). Test equipment and sync generator equipment, of course, need not be duplicated.

As the color facilities of the station grow some additional equipment units will become necessary. In particular, some means of selecting a picture from one of several sources and feeding it to the transmitter must be provided. Fig. 12 shows a combined functional diagram of all the equipment listed in *Steps 1 through 4*. Equipment groups are enclosed in broken lines and identified by letter as in previous pages. It will be noted that the output of the three camera chains (and the incoming network line) are brought out to a "Switching System" in an area marked "Studio Control".

The makeup of this "Switching System" will vary according to (a) its physical location, (b) the number of camera positions provided for, and (c) the "effects" facilities included. Some of the general con-

siderations in designing a color switching system are discussed in the next session.

Switching Considerations for Color

As might be expected, the switching of color signals requires considerable care and there are two apparent methods of accomplishing the necessary changes.

(1) It is possible to switch the signals before multiplexing which will require three sets of switching equipment, since three independent signals must be handled simultaneously.

(2) Conventional switching equipment methods may be used so that only a single output signal need be handled by the equipment. Thus, it becomes possible to use a standard Monochrome relay system with only slight modifications to accomplish camera switching functions.

The need for three identical sets of switching equipment is eliminated by using a Colorplexer as part of each camera chain—so that only a single output signal (containing a subcarrier component) need be switched. When this approach is used, the synchronizing signal is added at a common point after switching, so that control information to the deflection circuits of home receivers is never interrupted. There are some cases where switching of control information along with the picture information is unavoidable (for example—switching from local to a remote). In such cases, it is not uncommon for the picture to "roll over" once on home receivers before the vertical oscillator resumes control. This problem is no different in color television than in Monochrome. In either case, special "Genlock" devices may be devised to avoid this problem by locking in the local synchronizing generator (and subcarrier oscillator, in the case of a color system) to the generator controlling the remote signal source.

To insure that color synchronizing bursts are always in the proper phase relative to the subcarrier components of the video signal, it is desirable to provide burst keyers within each Colorplexer. This adds the bursts to the rest of the subcarrier signal as soon as possible after modulation, giving no opportunity to drift in relative phase. Switching equipment intended to handle multiplexed (single channel) color signals must have carefully adjusted delay characteristics. The reason is so that the time delay for signals passing from any of

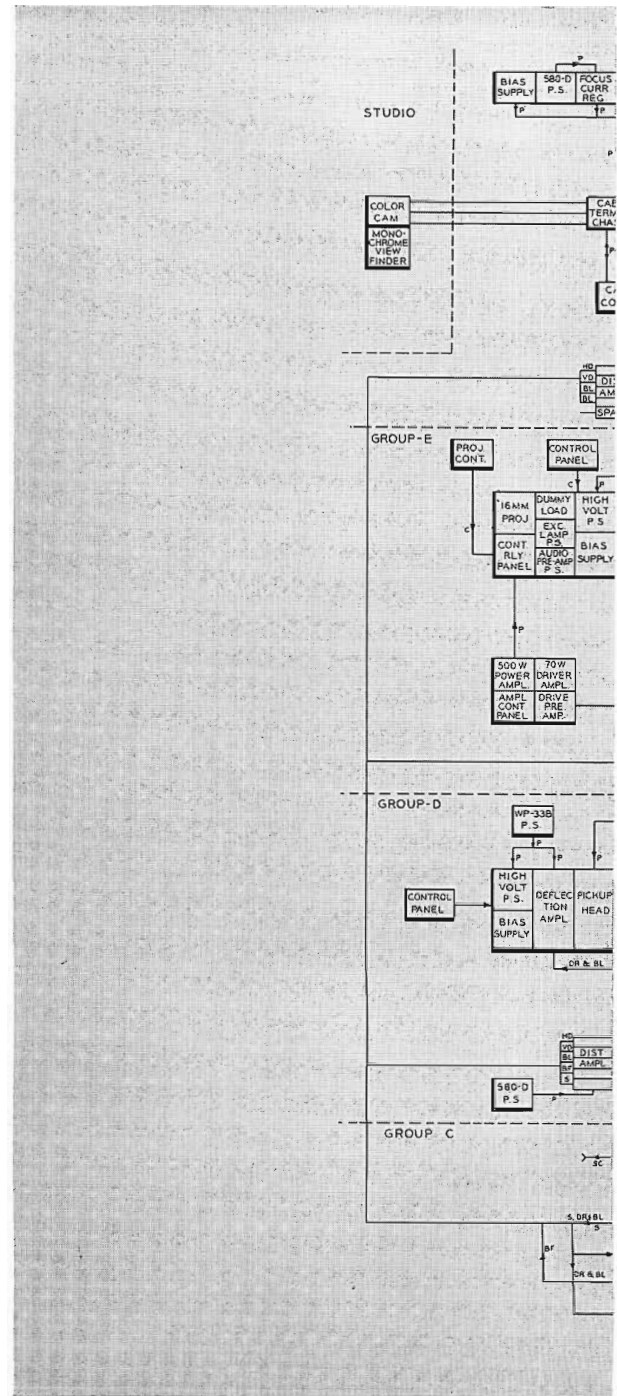

HELP IN MAKING YOUR COLOR PLANS

Every television station will have its own special problems in converting to color. RCA Field Sales Engineers have been provided with the information needed to help stations solve these problems. They have detailed information on all RCA Color TV Equipment, including suggested arrangements for every size station. In the case of stations needing special switching arrangements, or other custom built equipment, they can call on the RCA TV Systems Engineering Group for assistance. This help is available to all stations without obligation.

the Colorplexers to the common point where synchronization is added will be approximately the same (within 10 or 15 degrees at the subcarrier frequency) no matter what switching combination is actually in use. This avoids the problem of forcing receiver oscillators to adjust themselves to different absolute phases each time a signal is switched. To prevent complete loss of color synchronizing information when the picture is faded to black, it is desirable to provide one input to the switching system consisting of nothing but burst; this may be labelled "black."

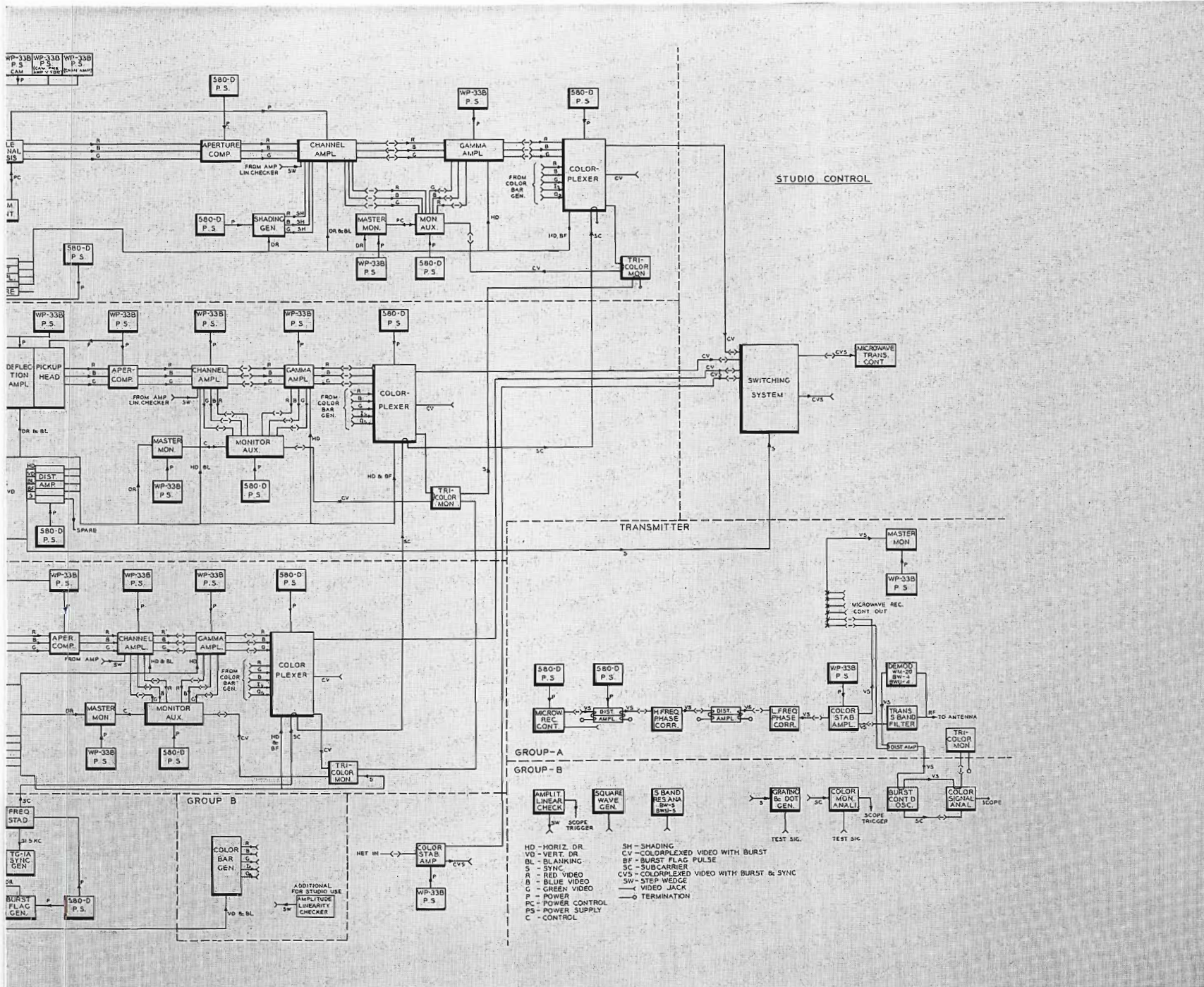

FIG. 12. Combined functional diagram of all the equipment listed in Steps 1 through 4. Equipment groups are enclosed in broken lines and identified by letter. In addition, the use of a switching system for selecting the color program to be transmitted is indicated.

LIGHTING FACILITIES FOR COLOR TV

The lighting equipment used for Color Television productions is the same as that required for comparable Monochrome sets—except for the amount of incident light necessary. A show that is properly lighted for black and white, with effects, low key and mood lighting may be duplicated for Color with no changes, except for the substitution of light fixtures of higher output (standard voltage, long-life bulbs may be operated at about 2900 degrees Kelvin).

Normal light levels should be such that the maximum highlight brightness in a scene is about 260 foot lamberts. Contrast

20 to 1 ratio, although for effects such as range should be maintained at about a silhouettes, the lowlight is below the ratio indicated.

The techniques of lighting, hanging of fixtures and control of power to the lamps requires no changes. However, the addition of color gives apparent depth to the scene and a separation of actors from the sets that cannot be achieved in Monochrome. The use of colored lights opens up an entirely new field of lighting effects that may be used to enhance the beauty of programs. For example, colored lights can

be used with neutral backgrounds to provide a number of different color combinations. Inexpensive theatrical gelatin filters may be placed in front of standard light fixtures. The three primary colors (red, blue and green) can be mixed by controlling the lamp voltage at a dimmer board. With a preset system, which is desirable for color, brightness of individual lamps in a grouping may be returned to the same brightness by manipulation of a single control at the lighting control console. Such facilities improve the ease and precision of returning to any pre-arranged condition.

SPACE REQUIREMENTS FOR COLOR TELEVISION

It is apparent from the foregoing descriptions that considerable additional equipment is necessary to meet the needs of Color TV programming. Moreover, the Broadcaster may retain and keep in everyday use his existing black and white equipment to provide an integrated operation. As will be evident from other articles included in this issue, some of the present Monochrome equipment may be adapted for color use—while other items will be retained solely for black and white use. In any case, a certain amount of additional space will be required as will be noted by referring to rack layouts and equipment lists included in this article.

The total space a Broadcaster must provide for Color TV operations will vary according to the scope of the proposed operation. For example, "network color only" stations will require very little additional space—while those stations who plan to use slide, film and live camera facilities must do more serious planning.

From observations of many existing stations it is obvious that most will either have to hunt for additional space, build it, or take existing space for color use such

as present AM space or even doubling up in present Monochrome studios.

There are undoubtedly many ideas which may occur to individuals concerning their own requirements, as for example providing a second deck for a control room where ceiling height is not limited. It is further suggested that before details on planning for color equipment are frozen, the assistance of a systems planning group should be secured, in addition to that of a qualified TV consultant.

Usually the provision of a little extra space will be more than repaid by the ease with which later expansion can be made.

The careful planning and layout of wiring trenches or ducts is essential in every color plan, once the amount of technical equipment has been determined.

RACK SPACE REQUIRED

Fig. 13 shows the rack layout (except switching equipment) for a *Step 4* Station, i.e., a station with one slide camera, one film camera, one studio camera and "net-

work" facilities. The units shown on the racks are the same as those shown on the functional diagram of Fig. 12. The circled letters on each unit indicate the equipment grouping to which the unit belongs. These are the same equipment groupings that were listed in preceding pages. Thus a station proposing to use less equipment can easily figure out how many racks to allow for. For example, a station with no live cameras will not have Group F equipment and, therefore, will require fewer equipment racks. Similarly, a station planning to use more cameras can easily estimate the additional rack space required.

CONSOLE SPACE REQUIRED

Each camera chain—whether slide, film or studio—includes two units designed for console mounting. One of these is a Type TM-6B Master Monitor (for monochrome monitoring of separate R, G and B signals). The other unit, of matching size, contains all of the tri-color camera controls. The two units are ordinarily mounted in standard console housings which are identical to those used in RCA monochrome installations. A closeup of the two console units used with each camera is



FIG. 14. Studio scene of Color Telecast. Note that color camera is used in conjunction with standard equipment such as the two-man dolly, lighting equipment, mike, booms, etc.

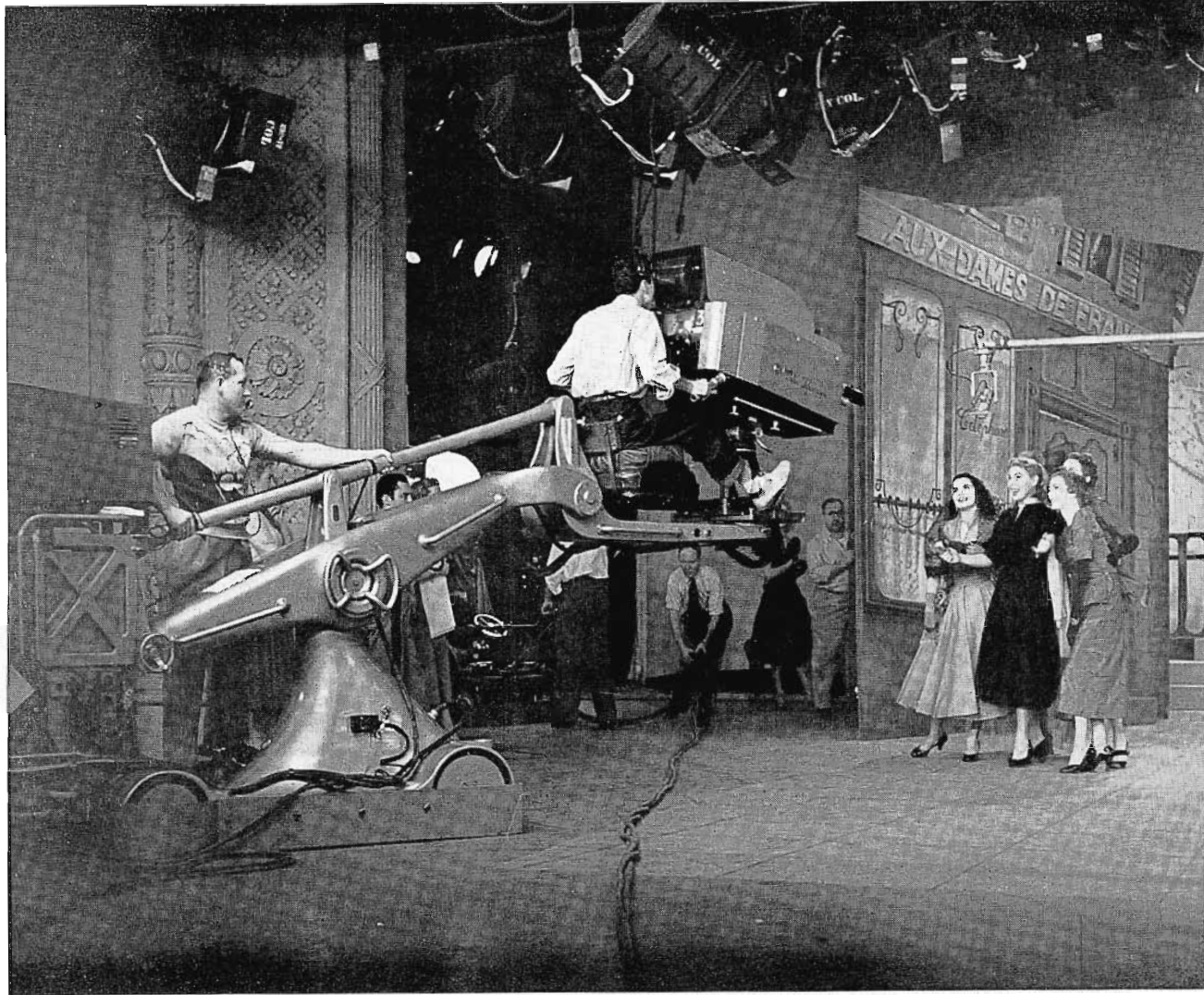
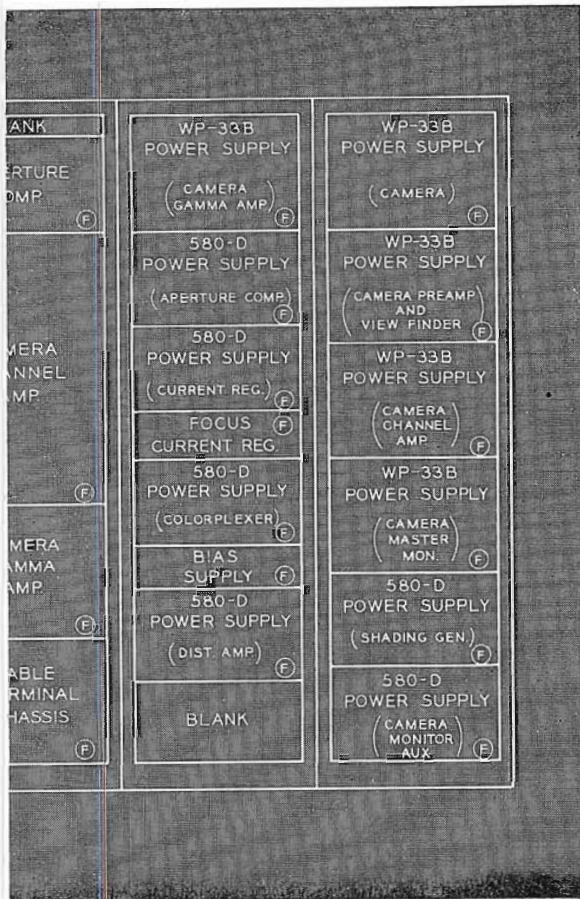

FIG. 13. Rack layout for all of the equipment listed in Steps 1 through 4. Units are the same as those shown in Fig. 12. Circled letters on each panel indicate the equipment group to which unit belongs. If a relay-type switching system is used additional rack space will be required for this.



shown in Fig. 3 on Page 63. These units, of course, can be combined with other camera units to form a control console such as that shown in Fig. 1 on Page 20.

CAMERA SPACE REQUIRED

The Color Studio Camera is somewhat larger than a standard monochrome camera (see Page 62). However, it is moved by the same type dollies and, therefore, does not in itself require more floor space. However, it is somewhat less maneuverable to use and this may lead to a more widespread use of two-man dollies. As a consequence somewhat more camera operating space may be desirable.

The Slide Camera proper is mounted on top of two short cabinet racks which require a floor space of approximately 51 by 18 inches. In addition, there must be a clear space of about 30 inches on each side so that the 20-inch cabinet doors can be opened for equipment maintenance.

The Film Camera proper is mounted on the top of three short cabinet racks which require a floor space of 75 by 24 inches. Here also space must be left for access, and convenient working room on both sides.

STUDIO SPACE REQUIRED

The stage, or performing, space required for color is no greater than for monochrome. However, the need for more lighting facilities, greater camera operating space and a wider assortment of backdrops will probably lead to the use of larger overall studio areas. It is likely that most stations will start by making use of existing studios (possibly adding a separate control room for color). When new studios are to be built especially for color the best present advice is to follow monochrome design practice but increase dimensions by 30 to 50% throughout. Standard plans for TV stations of various sizes were shown in an article "Television—What And How To Build", BROADCAST NEWS No. 72, January-February, 1953.

Intercom and Audio for Color

Standard intercom and audio facilities should be provided for the same purposes as in Monochrome productions. In general, the layout of equipment facilities also may be the same as that used for black and white. For a complete description of such facilities, refer to BROADCAST NEWS No. 73 (Mar.-April 1953) "Four Versatile TV Station Equipment Plans."

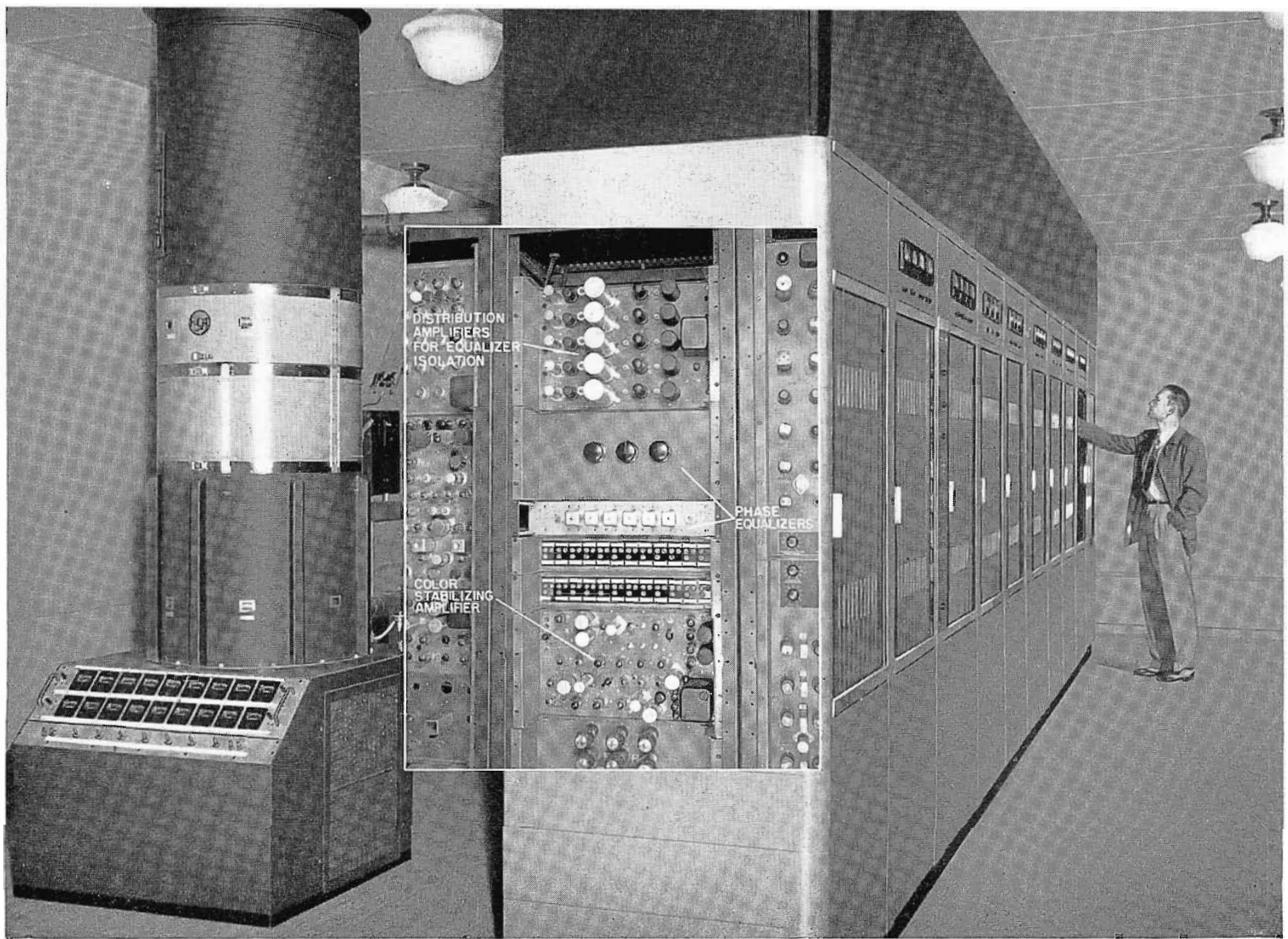

FIG. 1. Conversion to color mainly consists of adding some rack mounted input equipment as shown in the inset of the above photo. This equipment is installed external to the transmitter.

TELEVISION TRANSMITTER OPERATION WITH COLOR SIGNALS

PART I

TRANSMISSION CHARACTERISTICS IMPORTANT FOR COLOR BROADCASTING

by **T. M. GLUYAS**
and **N. J. OMAN**
Broadcast Transmitter Section
RCA Engineering Products Department

undertaken for monochrome transmission and has resulted in a general tightening of tolerances among the various transmitter performance specifications. In addition, some new specifications have evolved.

Linearity

The transfer characteristic of the transmitter should be linear. Of course the transfer characteristic of other parts of the television system or even the system as a whole is not ordinarily made linear, but if the linearity is controlled so that the picture looks good to the program director on a monitor which has the same transfer characteristic as a home receiver then other parts of the television system between the studio and the receiver should do nothing to disturb the desired effect. In other words, the transmitter should be linear.

Transmitter non-linearity can occur from many causes such as operation of video amplifiers on the non-linear portion of the tube characteristics, but the most common

The RCA color TV system operating on FCC signal specifications is a compatible system not only with regard to receiver operation but for transmitter operation also. No fundamentally new demands are made on the transmitter performance except a phase vs. amplitude requirement (described later) and a transmitter that does a good job of producing a high quality monochrome signal will also transmit a color signal. Any defects of transmission show up in a color signal in the same way as for a monochrome signal but in addition deterioration of the color quality may be observed. The fact that defects in color quality add to any defects in the luminance part of the signal (monochrome) has led to a much more exhaustive study of transmitter performance than was previously

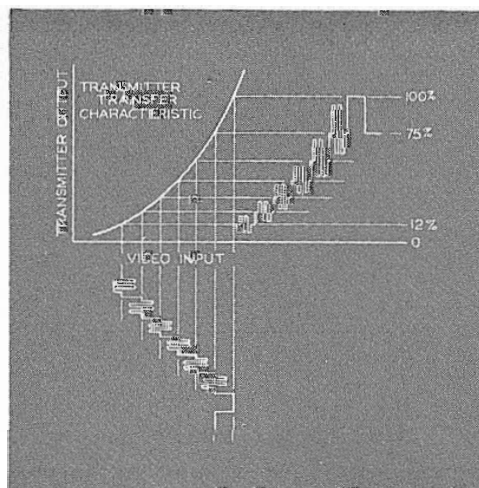

FIG. 2. Effect of non-linear characteristic on a test signal showing change in gray scale and color saturation.

cause of non-linearity is the distortion inherent in the process of grid bias modulation. This results in a curvature which compresses the incremental gain in the highlights of the picture. The effect is to reduce the detail contrast in the highlights which results in a slightly "washed out" picture. This defect has generally been tolerated in monochrome transmission but when transmitting a color signal the non-linearity has an additional effect on the picture.

A reduction of incremental gain reduces the magnitude of the color subcarrier which reduces the saturation of the color observed on the receiver. It may also shift the axis of the subcarrier signal which alters the brightness of the color. Fortunately this effect partially compensates for the reduction in subcarrier signal so that the colors if reduced in brightness may retain most of their original saturation. Summing up, the effect of non-linearity is to distort the gray scale rendition, and to modify the brightness and saturation of the colors present in the picture.

Fig. 2 shows how transmitter non-linearity would affect a test signal applied to the input terminals. The initial uniform steps with superimposed subcarrier signal are modified as shown so that the size of the steps (contrast) and the magnitude of subcarrier (color saturation) are reduced in the highlight region of the picture signal.

The waveform of the color subcarrier is distorted by transmitter non-linearity, but since harmonics of the distorted signal are outside of the assigned channel the color subcarrier is restored to sinusoidal form in passing through the frequency limited system. However, the axis of the sinewave will be shifted from the original value. This effect will be illustrated in the following section.

Extended Amplitude Range

It should be noted that good linearity is desired over a slightly greater range for color than for monochrome since highly saturated colors may extend into regions which are blacker than reference black and whiter than reference white. The most severe requirement is the transmission of a bright highly saturated yellow.

The wave form of the signal for various completely saturated colors is shown in Fig. 3A. The actual oscilloscopic display (Fig. 4) is slightly more complicated because this signal consists of color bars across the top of the picture and black, white, and I and Q reference signals across the bottom half of the picture. Notice that

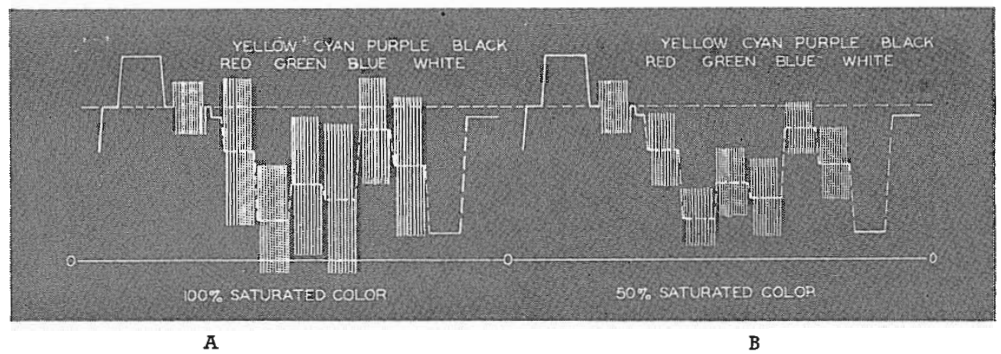

FIG. 3. Waveform of color bars showing relative luminance values (axis of waveform) and chrominance values (subcarrier amplitude) for the principle colors.

in Fig. 3A the peaks of the yellow waveform extend below zero carrier—an impossible requirement as this would call for transmitting a negative signal.

Completely saturated colors may be artificially generated but never under any conditions appear in nature. If color saturation

is reduced to 50%, the waveform will appear as shown in Fig. 3B. This is about the maximum saturation normally produced in a televised scene. For this case the signal does not require the transmitter to be modulated below zero output. Nevertheless the signal in the region between reference white and zero output will be badly compressed in any practical trans-

mitter. The magnitude of the subcarrier will be reduced with a consequent reduction in color saturation and the axis of the signal will be shifted toward black with a consequent reduction in brightness; the reduction in brightness tending to reduce an otherwise prominent reduction in color saturation.

Phase vs. Amplitude

Signal clipping is an exaggerated case of non-linear transmission. Even if the transmitter clips the signal completely at reference white, the reduction in the color subcarrier is not as great as might be supposed. Although the peak to peak value of the subcarrier may be reduced considerably the fundamental component of the subcarrier is reduced by only a few percent. These effects are shown in Fig. 5.

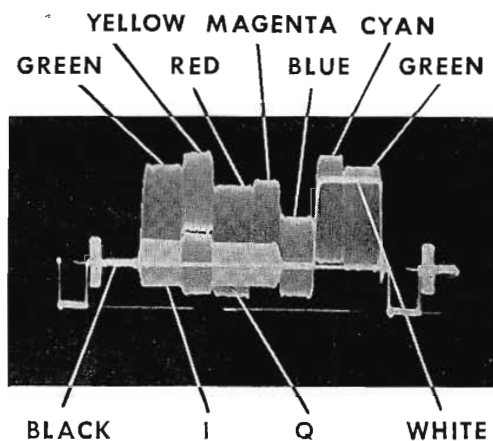
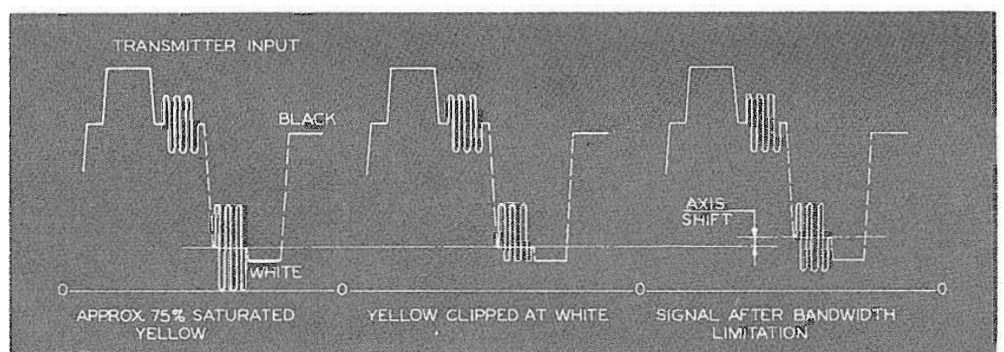

FIG. 4. Oscilloscopic presentation of color bar pattern (saturated colors).

mission is reduced to 50%, the waveform will appear as shown in Fig. 3B. This is about the maximum saturation normally produced in a televised scene. For this case the signal does not require the transmitter to be modulated below zero output. Nevertheless the signal in the region between reference white and zero output will be badly compressed in any practical trans-

FIG. 5. Clipped yellow signal showing reduction in subcarrier amplitude and shift of axis.



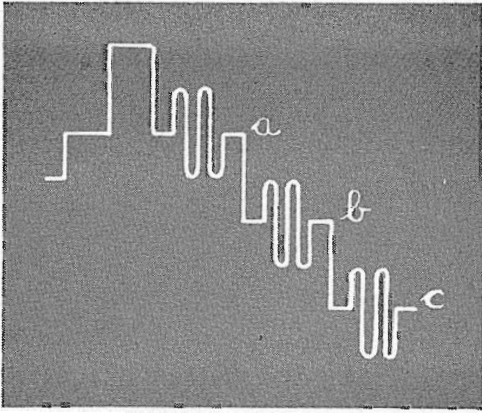

FIG. 6. Waveform to illustrate desired independence of brightness and subcarrier phase.

is in phase with the subcarrier at a. Suppose we wish to transmit a color which is brighter but has the same hue. Such a color would be shown by point c in the diagram and the subcarrier at this brightness level would have the same phase as the subcarrier at a or at b. If the transmitter has the property that the phase of the subcarrier is shifted as a function of brightness then the signal in passing through the transmitter would be altered so that subcarrier signals at a, b, and c would no longer have the same phase. The reproduced colors would be different not only in brightness but also in hue.

In the transmitter four defects may produce subcarrier phase shift as a function of luminance (brightness).

- (a) Diagonal clipping.
- (b) Parallel path transmission.
- (c) Variable impedance elements.
- (d) Incidental phase modulation.

FIG. 7. Effect of diagonal clipping on subcarrier phase. Top, Original subcarrier signal; Middle, Distortion due to diagonal clipping; Bottom, After eliminating harmonics, fundamental is shifted in phase.

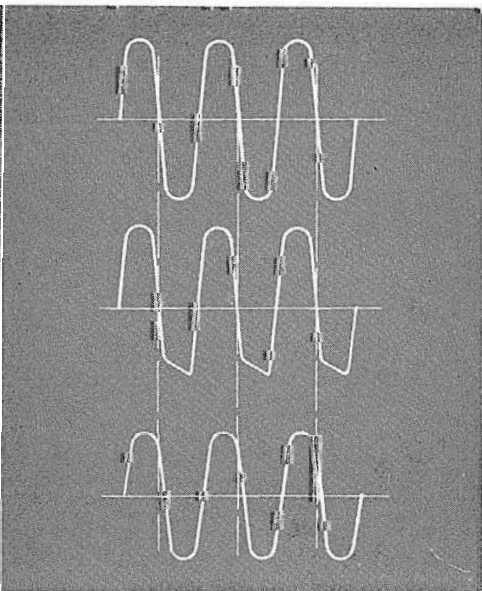

Diagonal clipping is shown in Fig. 7, and can occur when the non-linear portion of the transmitter includes circuits which have time constants of the same order of magnitude as the subcarrier frequency such as partially bypassed grid leaks in modulated stages, DC setting circuits with short time constant or spurious circuits in power supply leads to non-linear video amplifiers. After the distorted signal is restored to sinusoidal form in the bandwidth limited system, the final signal will be shifted in phase from the original. The effect can be seen in Fig. 7.

Parallel path transmission may be represented by the case of a video amplifier employing three tubes in parallel which have different characteristics either accidentally or purposefully arranged so that one or more of the tubes are non-conducting or partially conducting over part of the cycle. If the circuits associated with the tubes are not identical, the time of transmission of the color subcarrier may vary a tiny amount between a portion of the video signal where one tube is conducting and a portion of the signal where all tubes are conducting.

FIG. 8. Simplified schematic of feedback video amplifier.

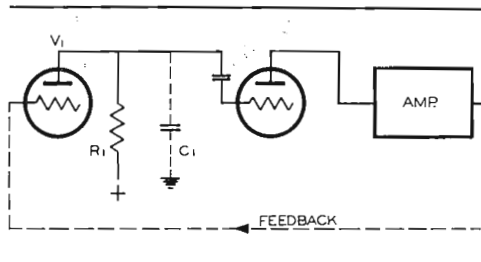

In the transmitter, variable impedance elements have been the most troublesome cause of phase shift vs. brightness. The simplest example, although not the worst, is a triode video amplifier whose plate resistance is a function of current and the signal amplitude is large enough that the current at black level and white level are radically different. Since the plate resistance varies as a function of brightness, and the plate resistance may be comparable to the reactance of the load at 3.6 mc, the phase of the color subcarrier signal will shift as a function of brightness. A cathode follower with a high impedance load is a similar and generally worse case of the same phenomenon. Cathode followers are often used to drive a load which is essentially a capacitance such as the input capacity of a modulator. Shunted across this capacitance is an artificial resistance—the internal impedance of the cathode

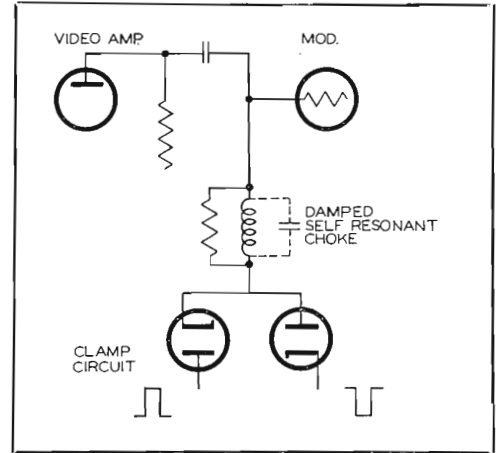

FIG. 9. Modification to "soften" clamp circuit. Damped self-resonant choke is inserted between clamp diodes and modulator grid.

follower. This impedance is a function of transconductance which is proportional to plate current.

A more subtle effect was found in the case of amplifiers employing negative feedback. If negative feedback is employed to correct for non-linearity and frequency response it is fundamental that the incremental gain around the feedback loop varies as a function of the position on the uncorrected transfer characteristic. It is typical of such feedback amplifiers that the interstage coupling circuit can be represented by a simple RC network as shown in Fig. 8. This circuit does not tell the whole story, for in shunt with resistance R_1 is the effective driving impedance of tube V_1 which has been made very low as a result of feedback. If the gain around the feedback loop changes, the driving impedance of tube V_1 changes, and consequently the phase angle of the subcarrier signal handled by this amplifier shifts. The effect is accumulative in each stage of the video amplifier.

The effect of incidental phase modulation in TV transmitters is well known with regard to the disturbance introduced in the sound channel of television receivers employing the intercarrier sound principle. Not so well known is the fact that incidental phase modulation also degrades monochrome picture quality. In addition incidental phase modulation may modulate the phase of the subcarrier as a function of luminance and color saturation, and thus disturb the hue. Fortunately it is usually true that when the incidental phase modulation is low enough to avoid buzz in the sound channel of intercarrier sound receivers it will also be low enough to prevent serious modulation of the phase of the color sub-carrier as a function of picture brightness.

Frequency Response

For monochrome transmission as well as for color the transmitter should have a uniform frequency response throughout the allotted pass band. This will permit the best possible transient response. The transient response affects resolution, ability to reproduce fine detail and sharp edges in the picture, and is a measure of smears and overshoots. All of these effects or defects are equally true in reproducing a color picture, and in addition the frequency response affects "chromaticity" and "color edges."

In order to have the correct "chromaticity", the response at the color subcarrier and frequencies a few tenths of a megacycle either side of the subcarrier must be equal to the response at lower video frequencies so that the signal level in the color (chrominance) channels of the receiver will properly be proportioned to the luminance signal. The receiver is equipped with a chromaticity control to adjust the relative signal level in these two channels, but, if the response is not properly maintained in the transmitter, the receiver chromaticity control would have to be adjusted in switching from channel to channel. This would restrict the range of control so that it might not always compensate for other variables such as frequency response of the receiving antenna and multipath effects.

Up to this point the discussion with regard to *Extended amplitude range*, *Linearity*, *Phase vs. amplitude*, and *Frequency response* have dealt with these characteristics as they affected the *large area color fidelity* of the picture with regard to hue, color saturation, and brightness. The *Frequency response* and *Envelope delay* characteristic also affect the *transient response* of the system. Since the television system is limited in bandwidth it is not possible to go instantaneously from one color to another anymore than it is possible to go instantaneously from one brightness level to another. Consequently, *colored edges* are formed at the sharp junction of any two large color areas and this phenomena is probably inherent in any color system of limited bandwidth. The characteristics of the FCC signal specifications have been chosen to minimize these color edges. However, any degradation of the transient response in the luminance channel or the chrominance channels will alter the nature of the color edges and invariably in a manner to make them more noticeable and objectionable.

The transient response in the luminance channel is determined by the frequencies extending throughout the whole channel

but mainly by frequencies extending from the visual carrier to 2 or 3 mc above the carrier. The transient response in the chrominance channel is affected by frequencies extending from 1.5 mc below subcarrier frequency (2.1 mc above visual carrier) to 0.6 mc above subcarrier frequency (4.2 mc above visual carrier). Consequently maintaining a flat amplitude vs. frequency response throughout the band is more important for color than for monochrome transmission. The FCC signal specifications require the response at 3.6 to be within ± 2 db of the response at 200 kc and in addition require the response from 2.1 to 4.18 mc to be flat within ± 2 db.

Envelope Delay

Most of the remarks which have been made regarding amplitude vs. frequency response also apply to phase vs. frequency response and to envelope delay. Envelope delay is simply the slope of the phase characteristic. The envelope delay of the overall system including transmitter and receiver should be constant at all video frequencies. If this is not true the various components of the signal which constitutes the complex video waveform will not pass through the system in the same amount of time and will consequently not add up at the output of the receiver to produce a waveform identical with the original. The result will be degradation of the transient response analogous to that obtained when the amplitude vs. frequency response is not constant. Since non-uniform envelope delay deteriorates the transient response it will have an undesirable effect on the color edges at the sharp boundary between large color areas especially if they differ in brightness as well as in hue. If the envelope delay in the vicinity of the color subcarrier differs from the envelope delay near the visual carrier the timing of the transitions of information in the chrominance channels will not match the timing in the luminance channels. The transition from one color to another will not occur at the proper rates with regard to brightness, hue, and saturation.

Unfortunately envelope delay is not independent of frequency in a practical television system. It is rather fundamental that a change in the slope of the phase characteristic occurs near the cutoff frequencies in bandwidth limited systems. Thus the sideband filter (or its equivalent in systems employing several linear amplifiers) produces phase errors near the visual carrier and the sharp IF cutoff and sound notch in receivers produces phase errors at

frequencies of 3-4.5 mc above visual carrier. The result is an increasing envelope delay at each end of the video band which can be partially corrected by the use of phase equalizers in the transmitter input terminals.

Transmission of Color Sync Pulse

A further requirement of the transmitter when handling color signals is that the synchronizing waveform be faithfully reproduced including the synchronizing burst. Ordinarily this presents no hardship except that the clamp circuits which normally clamp on the back porch following the horizontal synchronizing pulse must be designed or modified so that the burst will not be reduced in amplitude or shifted in phase during the clamping interval. This is easily achieved by designing a clamp circuit whose impedance is high compared to the circuit being clamped particularly at the subcarrier frequency. Such a circuit would include a high resistance or a highly damped high impedance 3.6 mc tuned circuit in series with the diode clamp as shown in Fig. 9.

Intercarrier Stability

For monochrome or color transmission it is desirable to maintain a high order of stability of the frequency separation between the aural and visual transmitters in order to obtain exactly 4.5 mc IF generated in receivers incorporating the intercarrier sound principle. For color transmission good intercarrier stability is also required in order to interlace and make less noticeable spurious low frequency signals in the picture produced by the beat between the sound channel and the relatively strong color subcarrier in the visual channel. The intercarrier frequency tolerance for color transmission has been set at ± 1000 cycles.

VSBF Lower Sideband Subcarrier Notch

For monochrome transmission VSBF filters have been designed to produce an attenuation of -20 db over the lower sideband counting on the inherent low amplitude of high frequency video components in a typical picture to maintain the signal radiated in the adjacent channel to -60 db or more below the synchronizing peak carrier level. When transmitting color signals the VSBF filter must provide an attenuation of -42 db at a frequency of 3.6 mc below the visual carrier to insure that the signal radiated on this frequency will always be at least -60 db below synchronizing peak level when transmitting highly saturated colors.

PART II APPARATUS REQUIRED

It has been considered acceptable for monochrome transmission to tolerate a certain amount of non-linear phase characteristic (variations in envelope delay), and a certain amount of amplitude non-linearity. Improvements are in order for color broadcasting. As a practical matter it is more economical to permit some errors in the transmitter and offset these defects by pre-distortion of the video signal feeding the transmitter. The block diagram of the transmitter input apparatus shown in Fig. 10 includes equalization for the phase characteristic of the transmitter, pre-distortion for the phase characteristic of the average receiver as specified by FCC Signal Specifications and correction for amplitude non-linearity of the transmitter.

Internal Transmitter Modifications

The auxiliaries set forth above and included in the block diagram of Fig. 10, permit any RCA transmitter to meet the FCC signal specifications with respect to linearity, frequency response and envelope delay. Some internal transmitter modifications are required in some of the transmitter types, e.g. RCA TTU-1B, TT-10AL and TT-10AH to meet the close tolerance permitted on the variation of phase of the color subcarrier vs. amplitude. In all of the transmitters it is necessary to add the clamp softening circuit shown in Fig. 9 to prevent the clamp circuit from reducing the magnitude or shifting the phase of the color synchronizing burst during the clamping interval. The transmitter modifications developed to improve the color carrier phase

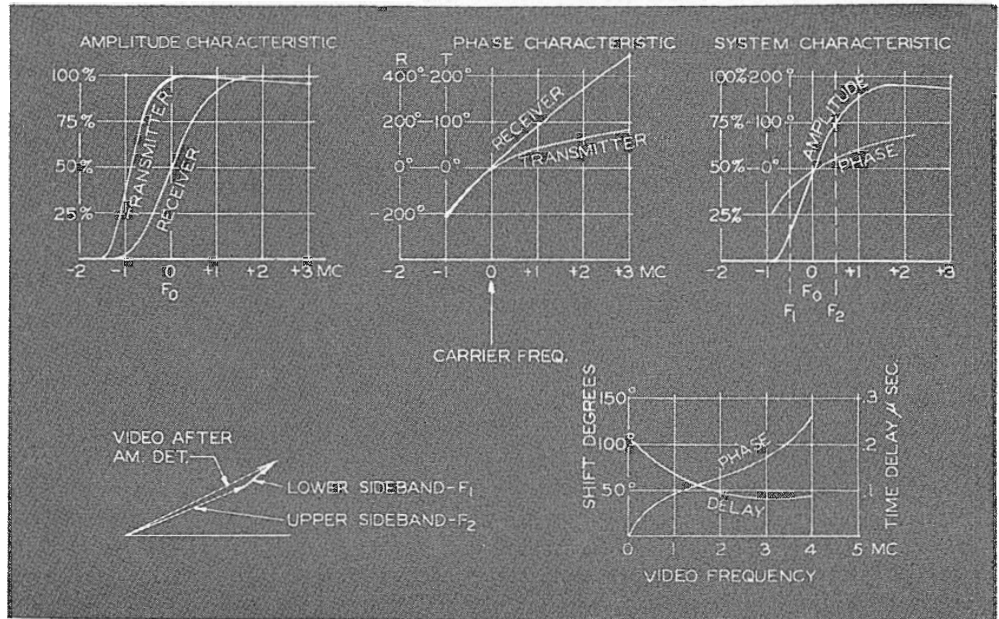

FIG. 11. Relation between transmitter and receiver amplitude and phase characteristics and the required phase characteristic of the low frequency delay equalizer.

vs. amplitude include circuit changes to reduce capacitance in video amplifiers and modulators which utilize negative feedback, circuits to stabilize impedances that normally vary with picture brightness, and circuits to cancel filament circuit inductance in modulated RF amplifiers.

Low Frequency Phase Equalizer

A typical receiver will introduce a small amount of phase error in the low frequency video components of the television signal. Since this defect may vary from one design to another no agreement could be reached among receiver engineers and manufacturers of a detail specification of predistor-

tion as this would tend to restrict the freedom of design. Furthermore, some receivers have made elementary attempts to correct for their own phase errors and there is considerable possibility that future receiver designs may incorporate such corrections more fully.

In summary, a low frequency phase equalizer is intended to correct for the low frequency phase errors introduced in the transmitter only and not for the phase error of the receiver although as will be shown later it is not possible to completely divorce the contribution of these two parts of the television system. The low frequency phase equalizer is made variable in order that it can take care of the variations that may exist from one transmitter to another depending upon the channel involved, the type of vestigial sideband filter used, and minor variations in the adjustment and circuitry of the transmitters.

It is difficult to explain accurately in a short paragraph the interlocking effects of

FIG. 10. Block diagram of apparatus required for color broadcasting.

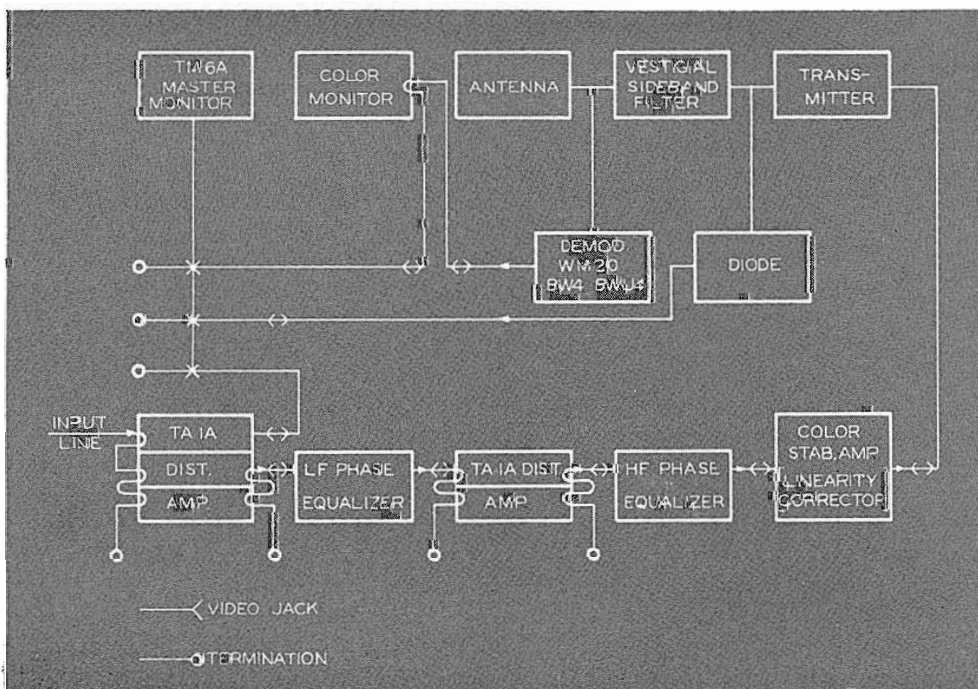
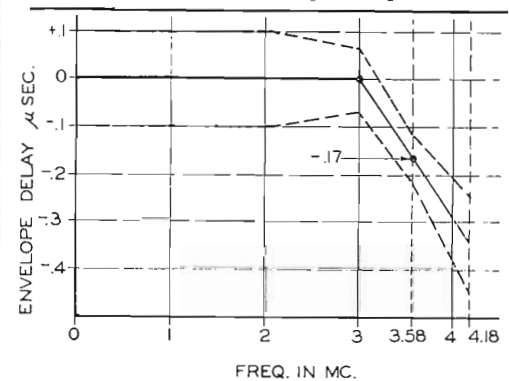

FIG. 12. FCC signal specification of the transmitter envelope delay.



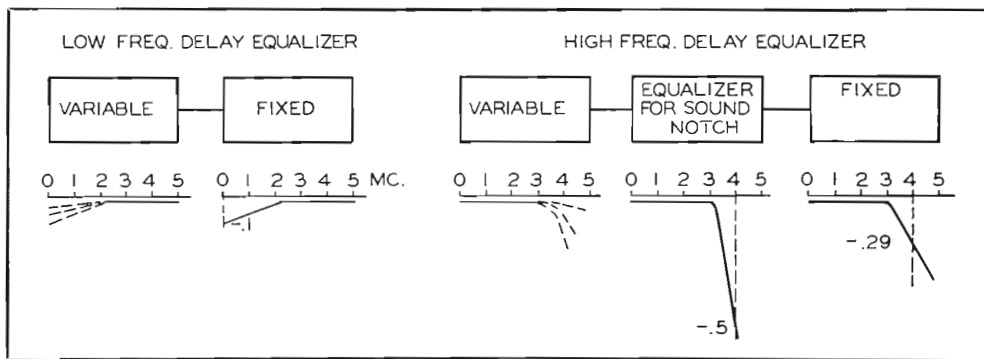
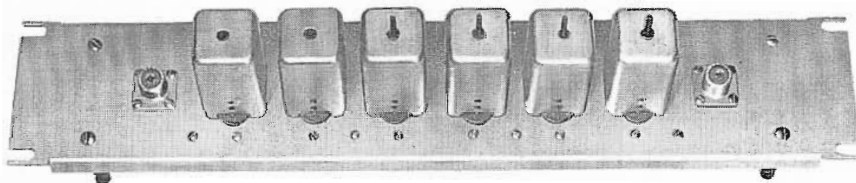

FIG. 13. Functional division of phase equalizers.

the transmitter and receiver in determining the requirements of the phase equalizer. If phase equalization could be accomplished in the RF circuits of a transmitter in a practical manner, then transmitter equalization could be effected without regard to receiver characteristics. Since video equalization attempts to correct for phase errors in the RF circuits which include effects of both upper and lower sidebands, the correction should be modified slightly if the ratio of the upper and lower sideband is changed by assuming a different receiver selectivity. This affects the requirement for the low frequency phase equalizer but not the high frequency equalizer.

Fig. 11 illustrates the above discussion. The selectivity and phase characteristics of transmitter and receiver are shown. System response curves could be formed by multiplying the selectivity curves and adding the phase curves; however, by industry agreement, the receiver phase characteristic is ignored or assumed linear in arriving at the pseudo "System Characteristic" shown. For each modulating frequency, the contribution of upper and lower sidebands are added vectorily to find the equivalent video amplitude and phase response as illustrated by the vector diagram. The phase characteristic is converted to envelope delay by plotting the slope of the phase characteristic. The phase equalizer is designed to have a complementary delay curve so that the sum of the system delay and the equalizer delay produces a delay which is independent of frequency.

FIG. 14. A portion of the high frequency phase equalizer employed to obtain the delay specification given in Fig. 12.



Distribution Amplifiers

The block diagram of Fig. 10 shows distribution amplifiers inserted between the equalizers and also preceding the first equalizer. These units perform the function of isolation amplifiers and serve as 75 ohm signal sources for each of the networks to absorb any minor reflections that may be produced in the phase equalizers. Since the phase equalizers have introduced a great deal of time delay, the slightest mismatch will produce an echo of considerable displacement in the picture. Furthermore, phase equalizers constructed of passive circuits are very critical with regard to termination and if the input impedance of one equalizer became the terminating impedance of another, the accumulated errors of impedance mismatch would be rapidly compounded.

High Frequency Phase Equalizer

The transmitter envelope delay specified by the FCC is shown in Fig. 12. This is intended as predistortion to correct for the delay error of an average color receiver. The necessity for maintaining nearly full response to a frequency greater than 3.6 mc above the carrier and for obtaining almost complete rejection at the sound frequency—4.5 mc above the carrier—determines a rate of receiver cutoff and consequently the phase characteristic with little chance of major deviations from the average.

The high frequency phase equalizer in addition to containing the circuits necessary to achieve the delay equalization spec-

ified by the FCC also contains a group of circuits to introduce equalization for the high frequency phase errors (envelope delay) caused by the extremely rapid attenuation characteristic of a notch type diplexer or a filterplexer when these types are used. Where a bridge diplexer is used this portion of the delay equalization is not required and these circuits may be by-passed.

The high frequency phase equalizer also contains a variable section of delay equalization to compensate for differences in transmitter design and adjustment. The amount of variation required is not as great as might be supposed, even though some transmitters contain more RF circuitry than others, because the rate of transmitter cutoff due to these circuits is extremely gradual compared to the rate of attenua-

FIG. 15. Schematic diagram of the phase equalizer pictured in Fig. 14.

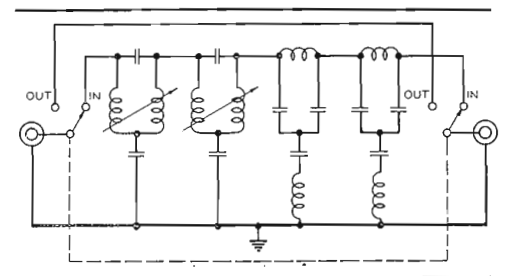

tion encountered in a receiver or notch diplexer.

Fig. 13 shows a functional division of the phase equalizer and an indication of the envelope delay characteristic of each portion. Fig. 14 is a photograph of the fixed portion of the high frequency phase equalizer and Fig. 15 is a schematic diagram of this unit.

Linearity Corrector

Any non-linearity in the transmitter may be corrected by pre-distortion with the use of a non-linear amplifier preceding the transmitter provided that one or two simple precepts or restrictions are followed. The various circuits between the non-linear elements in the transmitter and the non-linear elements of the pre-distorter must have reasonably flat frequency response and be reasonably free from phase errors otherwise the transient response will be different at different brightness levels. In the latter case a transition in a positive direction would not have the same shape as a similar transition in the negative direction. The desired condition is usually fulfilled in a television transmitter where the frequency response of the video amplifier is flat and not purposely accentuated to compensate for a deficiency in the frequency response of the RF circuits. As noted in Fig. 10 the phase equalizer precedes the linearity corrector.

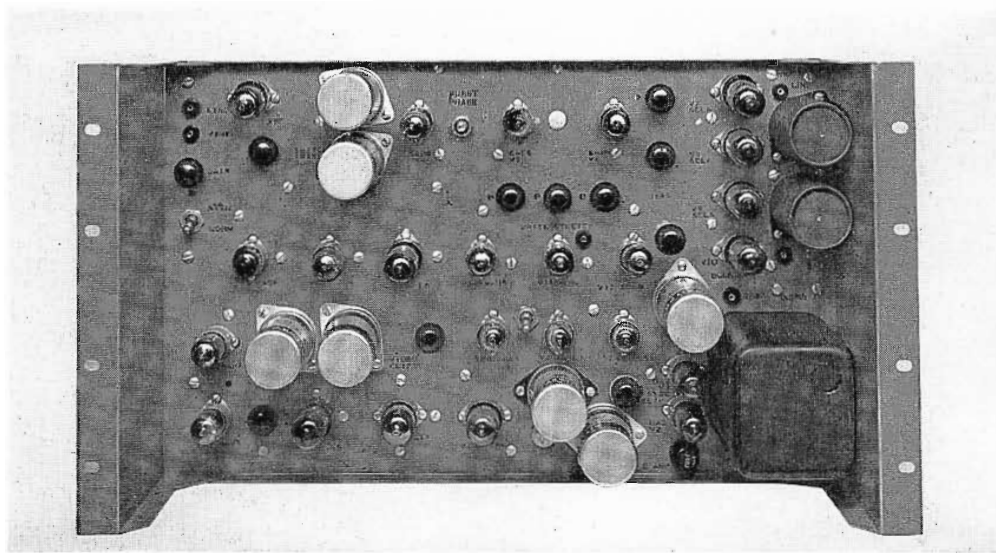
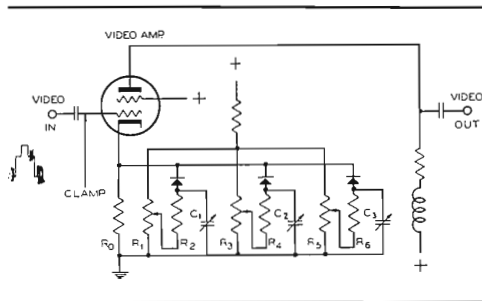

FIG. 16. Color stabilizing amplifier with built-in linearity corrector.

The non-linear pre-amplifier or linearity corrector must introduce the DC component in the non-linear stage so that the shape of the transfer characteristic will not depend upon the brightness of the picture. The slope of the transfer characteristic at each point in the range from black to white must complement the corresponding point on the transmitter transfer characteristic. Since the circuits necessary to introduce the DC component and the amplifiers required to obtain the level necessary for simple control of the linearity are duplicates of functions already performed in the stabilizing amplifier it is sometimes con-

FIG. 17. Schematic diagram of non-linear amplifier, employed in the color stabilizing amplifier.



venient to incorporate the linearity correcting circuits in the stabilizing amplifier, with an overall saving in tube complement.

Fig. 16 is a photograph of a color stabilizing amplifier which includes circuits for control of the non-linear transfer characteristic. Fig. 17 is a schematic diagram of the non-linear amplifier incorporated in this stabilizing amplifier. The principle of operation is as follows. A video amplifier with the DC component reinserted (clamped) has a large amount of degeneration by reason of the relatively large cathode resistor R_0 . The cathode resistor,

however, is shunted by a group of biased diodes which connect additional resistance across R_0 at preset amplitude levels thus changing the gain of the amplifier as a function of the instantaneous amplitude. By changing both the bias on the diodes and the resistance in series with them a wide range of non-linear characteristics can be obtained.

Monitoring Facilities

The facilities required for operation and monitoring of the color transmission are the same as for monochrome except for the obvious desirability of a color monitor. The presently available color monitor is not intended for use in the transmitter operating console so the normal console functions are not disturbed. The connection of the color monitor in the transmitter system is shown in the apparatus block diagram of Fig. 10. The color monitor does not have push button selection of monitoring points but it can be connected to monitor either input signal or transmitter output by video patch cord manipulation without program interruption. A point to be observed in the block diagram of Fig. 10 is that the input monitoring precedes the phase and amplitude equalizers. Monitoring at any other point between the signal source and the output monitor would contain a certain amount of signal pre-distortion.

PART III

TECHNIQUE OF ADJUSTMENT AND TESTS TO DETERMINE COMPLIANCE WITH STANDARDS

The important transmission characteristics for color have been discussed in a preceding section. Some of these such as

the ability to transmit the special color synchronizing pulse, the question of inter-carrier stability, and the requirement for the attenuation of the lower sideband color subcarrier signal are either matters of design or the technique of measurement is obvious from the specification. The other characteristics which must be measured as a routine matter of transmitter adjustment are:

- (1) Amplitude vs. frequency.
- (2) Linearity.
- (3) Phase vs. amplitude. (Phase of the color subcarrier as a function of its position in the amplitude range from burst toward white level.)
- (4) Envelope delay vs. frequency.

These characteristics have been listed in the order in which adjustment should be performed, although some of these characteristics may be found to interlock to some extent.

Adjustment of Frequency Response

Adjustments of the transmitter for best frequency response is the same regardless of whether the transmitter is intended for monochrome transmission or color except that particular attention must be paid to the color subcarrier frequency and the frequency range from 2.1 to 4.18 mc. The best tools to use are a sideband response analyzer (BW5A, BWU5A) and an oscilloscope. The video output of the sideband analyzer should be applied directly to the transmitter input terminals. The transmitter output sampling (sideband analyzer input) may be taken before the sideband filter, for convenience in transmitter tuning, and later transferred to the output of the vestigial sideband filter to check the overall frequency response. Fig. 18 is illustrative of the results to be expected using this technique. As an additional check a diode may be employed after the vestigial sideband filter to obtain the frequency response as specified in the FCC standards of good engineering practice. Another overall check that can be made is to observe the frequency response of the video signal at the output of the vestigial sideband demodulator (BW4, BWU4, WM20) with the 4.5 mc traps removed. The response should be flat within 2 db to 4.18 mc.

Adjustment of Linearity

In making a final adjustment of overall linearity it is necessary to determine the proper setting of transmitter gain control so that when the transmitter is fully modulated with a normal picture the stabilizing amplifier will be operated at the correct level to insure normal operation of the

clamping circuits, white stretcher, and other functions. Once this setting has been determined by observing the overall transmitter performance, power output, and depth of modulation the transmitter gain control must be locked in place and not changed throughout any subsequent adjustments in the linearity circuits or throughout normal programing. *The operating gain control must precede the linearity corrector* and this is conveniently done by using the remote gain controls for picture and synchronizing provided in the stabilizing amplifier.

A linearity checker designed to facilitate transmitter linearity adjustment is described in a companion paper "Test Equipment for Color Television", Page 78. The signal from this device consisting of a stepped wave with superimposed subcarrier may be applied to the input of the stabilizing amplifier or substituted for the normal signal source preceding the phase equalizer. For this test either of the transmitter demodulators may be used to feed the indicating device but there is some preference for the use of a diode detector preceding the vestigial sideband filter since this device when operated at the proper level is not apt to have the small residual errors in linearity which could occur in the more complex vestigial sideband demodulator. The output of the demodulator, of whatever type employed, passes through a high pass filter. It is often convenient to employ the high pass filter circuits built as an internal part of the color signal analyzer. The output is then displayed on an oscilloscope as shown in Fig. 19. This figure shows the waveforms produced by the linearity checker with and without employing the high pass

filter (Figs. 19A, 19B) and the waveforms out of the transmitter demodulator before linearity correction is applied (Figs. 19C, 19D). A poorly performing transmitter was purposely chosen to exaggerate the non-linear aspects for illustration and ordinarily smaller differences should be expected between input and output signals. After pre-distortion is applied the output signal should closely resemble the input waveform.

The magnitude of the subcarrier component after passing through the high pass filter is proportional to the slope of the transfer characteristic or the incremental gain. The individual bursts of the subcarrier corresponding to the separate steps of the initial stair step waveform may be distinguished by the slight transient associated with the leading edges of the steps. The incremental gain at 3.6 mc within the black to white amplitude range must not fall below 80% of the maximum incremental gain. It is a standard test condition to employ a peak to peak value of subcarrier signal equal to 10% of the 0 to peak of sync range. The first step should conform to pedestal level and the final step to reference white level. The number of steps is relatively unimportant, although 10 is a convenient number. The actual adjustment of the linearity correcting circuits is a matter of "knob twiddling" while observing the overall linearity as displayed in Fig. 19D.

Measurement of Phase vs. Amplitude

Without changing the circuit arrangement, the same test apparatus may be employed to observe the subcarrier phase vs. amplitude. If the linearity corrector in-

cludes adjustments for correcting its own phase vs. amplitude characteristics these adjustments should be made as soon as the linearity correcting adjustments have been set. The output of the stabilizing amplifier may be temporarily applied to a color signal analyzer for observation of the phase vs. amplitude characteristic while these adjustments are made. Following this, the overall phase vs. amplitude characteristic can be displayed by feeding the color signal analyzer with the output of the same demodulator just employed in observing transmitter linearity, taking care to employ the proper depth of modulation so that the last step, without any superimposed subcarrier, corresponds to reference white.

The sync portion of the step wave signal of the linearity checker contains no subcarrier component. This produces a zero phase reference on the 'scope presentation of the output of the color signal analyzer which is useful in calibrating the display observed on the oscilloscope. The color signal analyzer can insert an adjustable phase shift in the reference subcarrier component which is supplied as a continuous frequency from the linearity checker. By noting the change of the calibrated phase shift required to match the step levels on the oscilloscope to the reference (sync portion), variation in phase throughout the black to white range may be measured. Fig. 20 shows a display of the color signal analyzer output and the same display when the calibrated phase shift knob has been rotated through two degrees. The difference in level of the reference (sync portion) for these two photographs furnishes a calibration scale for the oscilloscopic display, and it may be seen that variations

FIG. 18. Sideband response analyzer presentation depicting frequency response of a television transmitter before (left) and after (right) the Vestigial Sideband Filter.

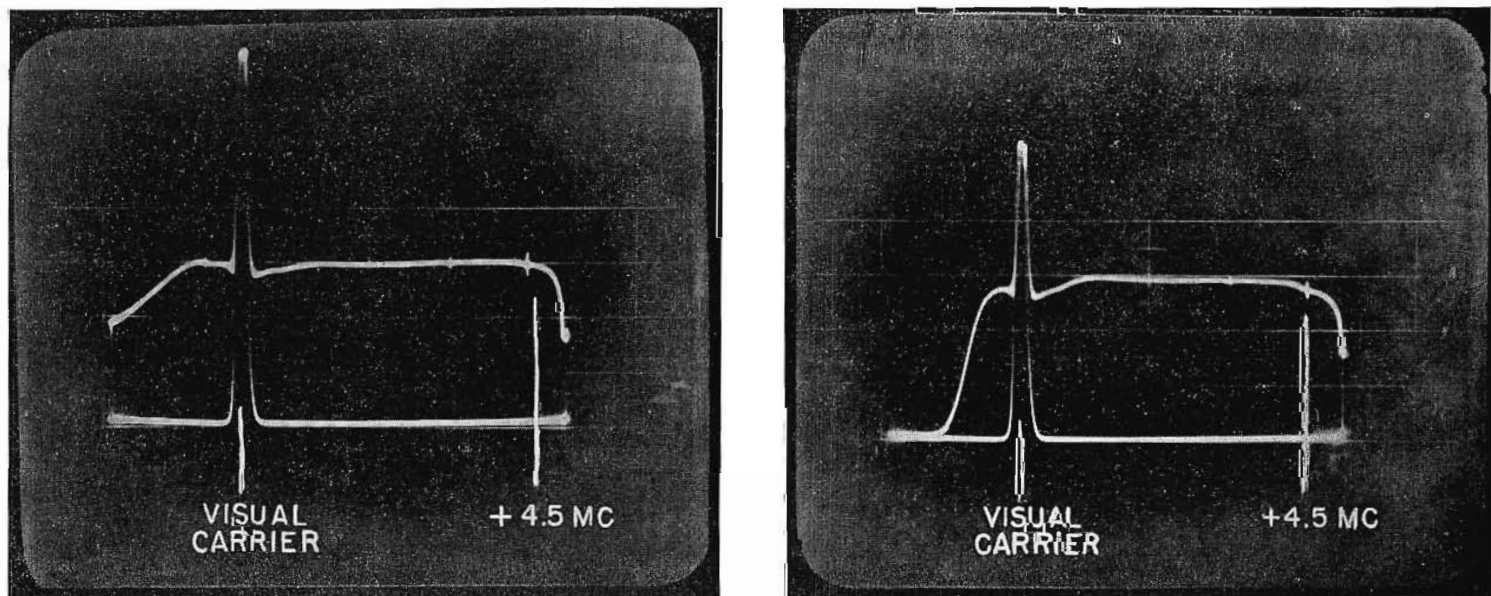

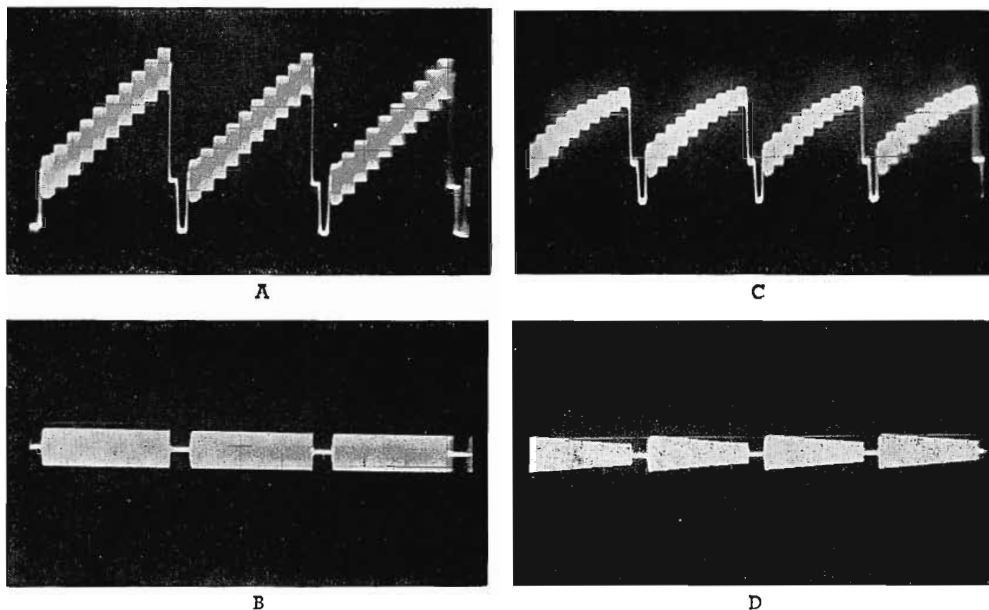

FIGS. 19A, B, C, D. Waveforms produced by linearity checker and transmitter. A. Waveform produced by linearity checker. B. High frequency component of linearity checker waveform. C. Waveform out of demodulator. D. High frequency component of demodulator output.

in the neighborhood of 1 or 2 degrees are readily apparent.

The total variation of subcarrier phase throughout the black to white range of the transmitter should be substantially less than 10 degrees. This is necessary so that the system, from camera to antenna, can meet the FCC signal specification which calls for the angles of the subcarrier with respect to the burst phase to be within ± 10 degrees of the proper angles for 75% saturated primaries and their complements.

Some transmitters may contain built-in adjustments in the video amplifier to correct the phase vs. amplitude characteristic. Where linear amplifiers are employed, there is a technique of adjustment which will reduce the amount of variation of subcarrier phase. The problem is that the phase of any frequency in the passband such as the color subcarrier is a function of the overall amplitude characteristic. That is to say, changes in the amplitude vs. frequency characteristic at frequencies other than 3.6 mc above carrier influence the phase of the color subcarrier. The rate of cutoff of the transmitter in the vicinity of 4 to 5 mcs also influences the phase of the 3.6 mc subcarrier. The input impedance of a linear amplifier changes as a function of amplitude due to variations in grid current and curvature in the tube characteristics (the latter is especially important in grounded grid amplifiers) and this causes the frequency response of the stage feeding the linear amplifier to change with amplitude. The frequency response at white level will be different from the frequency response at black level. This varia-

tion in the frequency response alters the phase of the color subcarrier, so the problem is to adjust the circuitry between the modulated amplifier and the linear amplifier to minimize the variation in the frequency response. One way to achieve this is to adjust these circuits to be wider than necessary; that is, wider than would be required if frequency response were the only criteria. The length of line between the modulated amplifier and the linear amplifier and the degree of coupling between

Adjustment of Delay Equalizers

these circuits has a strong bearing on the variation of frequency response with amplitude, but at this writing the tuning process is still more or less "cut and try" to achieve the desired results.

All of the preceding adjustments involve active circuits. They are effected to some extent by the operating levels of the vacuum tubes and consequently are interlocking to some degree. The final adjustments are the adjustments of the strictly passive delay equalizers which can be made without upsetting any of the preceding adjustments.

The delay equalizers may be adjusted with the aid of a square wave generator and oscilloscope or a new instrument—an "Envelope Delay Sweep"—may be employed. This device is described on Page 79. The square wave technique will be presented first.

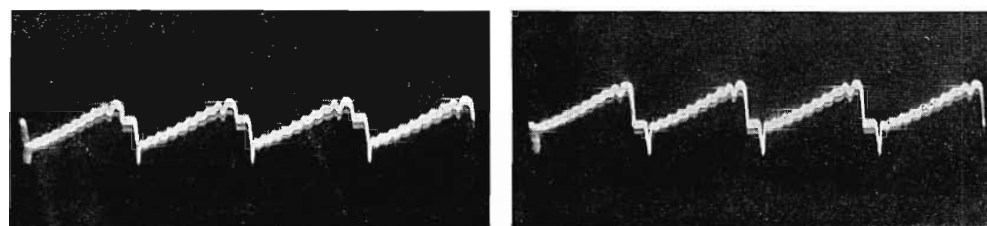
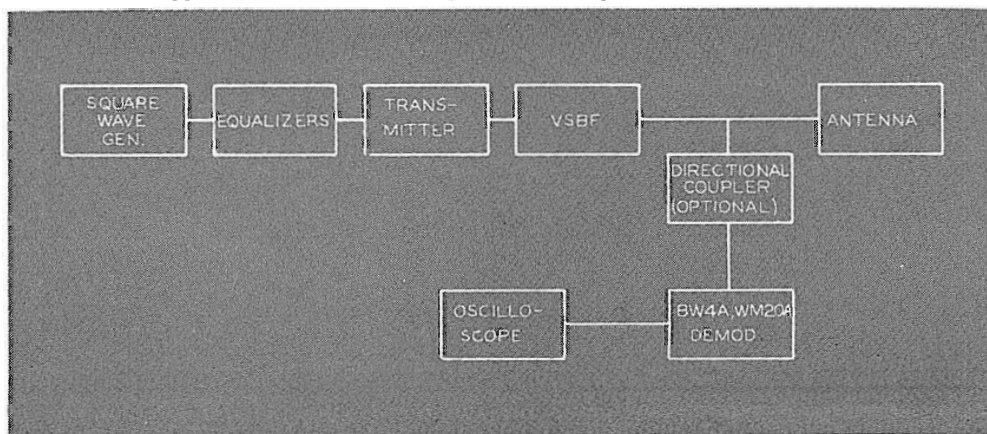

FIG. 20. Waveforms produced by linearity checker, transmitter and color signal analyzer. Calibrated phase control has been changed by two degrees between left and right pictures to establish vertical scale.

A square wave generator with a rise time of 0.5 microseconds or less, operating at a frequency of approximately 100 kc is substituted for the normal picture source. The stabilizing amplifier and receiver high frequency cut off equalizer are removed from the input circuit. The transmitter is set for AC operation. Signal level and bias are adjusted so the average power of the transmitter is about one-quarter peak of sync power and square wave modulation is of the order of 50% or less. A vestigial

FIG. 21. Apparatus arrangement for square wave response measurement of transmitter.



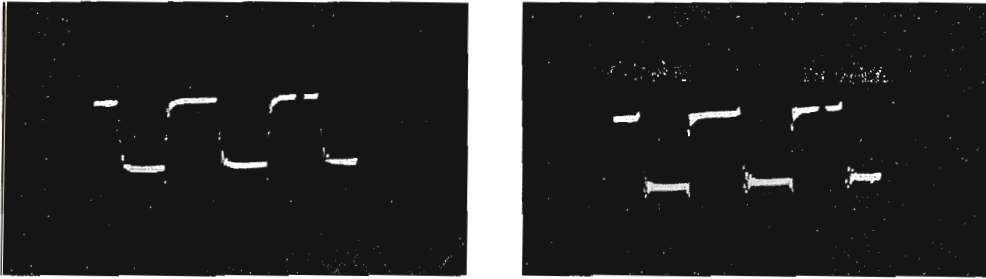

FIG. 22. Square wave out of transmitter and demodulator before and after delay equalization.

sideband demodulator (BW4, or WM20) in wideband connection (notches removed) is coupled to the output of the VSBF and the signal from the demodulator is viewed on a wideband oscilloscope (type 524D). A double sideband detector (diode) should not be used, either before or after the vestigial sideband filter. The apparatus arrangement is illustrated in Fig. 21.

The fixed portion of the high frequency phase equalizer is by-passed during the adjustment when the wideband connection of the demodulator is employed. The equalizer controls are manipulated for the best possible square wave. A typical set of square waves representing "before and after" adjustment are shown in Fig. 22. The objective is to make the leading and trailing transients symmetrical and as small as possible. The low frequency component of the distortion, because it introduces smear in the picture, is much more important than the high frequency ripple ("ringing"). The square wave adjustment technique will only result in the correct overall transmitter phase characteristic, specified by the FCC, when the demodulator includes phase compensation for its own low frequency phase errors. The monitor must produce a perfectly symmetrical transition with equal leading and trailing transients when the monitor is fed with a signal from a square wave modulated double sideband transmitter with low depth of modulation.

The adjustment of the phase equalizers can be made using an envelope delay sweep

in the apparatus arrangement of Fig. 23. With the fixed portion of the high frequency phase equalizer out of the circuit and with the demodulator set for wide band (sound notches removed), the output of the demodulator may be applied to the envelope delay sweep detector whose output is in turn connected to an oscilloscope. The overall system delay should be adjusted to a constant value (straight line on an oscilloscope) by manipulating the adjustments of the phase equalizers. The demodulator should be connected to the output of the vestigial sideband filter and in this case either a diode or a vestigial sideband demodulator may be used. If a diode demodulator is employed the display at frequencies below 1.5 mcs should be neglected. If a WM20 or BW4 demodulator is employed the display will be accurate for frequencies above 0.4 mcs but the display will include the residual delay errors of the demodulator.

After the overall system has been adjusted for uniform delay, the fixed portion of the high frequency phase equalizer may be inserted in the circuit and the overall delay for frequencies above .4 mc should correspond to the FCC curve, Fig. 12.

It should be emphasized that although the square wave technique and the envelope delay sweep method may be used interchangeably to adjust the equalizers, only the latter yields results which can be interpreted directly in terms of the FCC

FIG. 23. Apparatus arrangement employing an envelope delay sweep for phase equalizer adjustment and measurement of transmitter envelope delay.

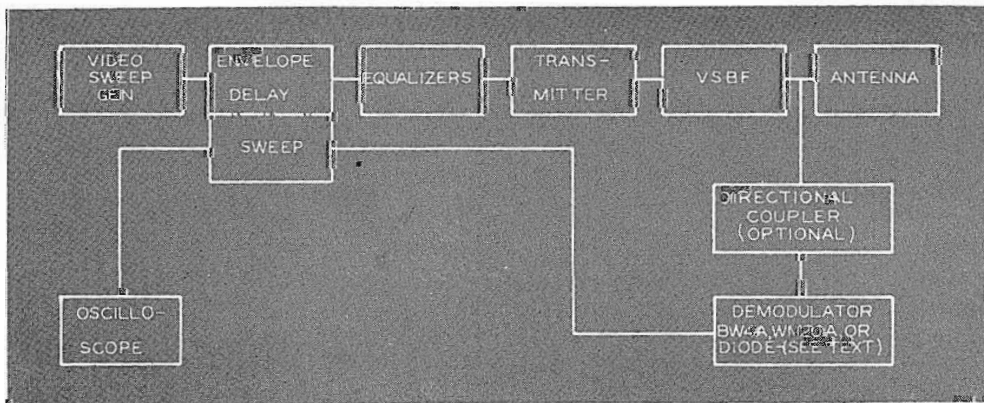

specification for envelope delay and even this does not give quantitative results for frequencies below approximately 0.4 mc. The best procedure at the moment appears to be the use of square wave technique for adjustment of the low frequency phase equalizer and the use of the envelope delay sweep to adjust the high frequency delay and to observe compliance with the FCC delay specification.

OPERATION

After all of the adjustments and checks described in these pages have been completed, the transmitter should operate with interchangeable or intermixed monochrome and color signals with no unusual attention. There is one final point to bring to the attention of those who have not yet had experience with the waveforms encountered in color broadcasting. Since the signals may occasionally contain perfectly normal subcarrier excursions in the region beyond reference white it is necessary to distinguish between these subcarrier peaks and white peaks, in order to properly set the transmitter depth of modulation. Some benefit may be derived by normally operating the waveform monitor with "IRE rolloff", occasionally switching to wideband position to check on the magnitude of the color synchronizing burst. The final figure—Fig. 24—is a waveform picture of a random color scene and the same scene with all color information removed. A comparison of these two waveforms will give some idea of the type of signal encountered in color broadcasting.

FIG. 24. Waveform monitor display of a typical color scene. Top, Full color scene. Bottom, Same scene but with color subcarrier removed.

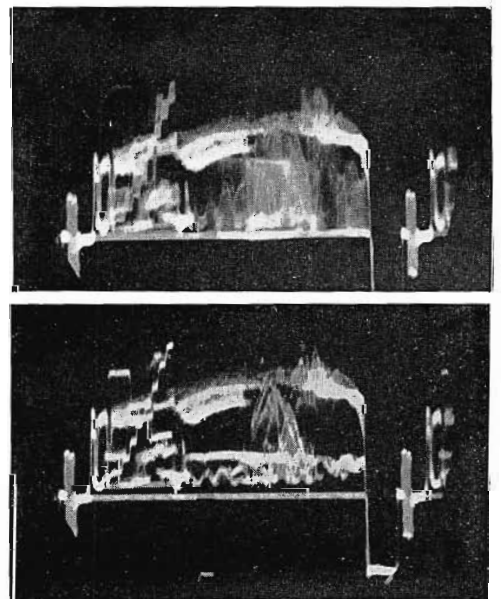

VIDEO AMPLIFIERS IN COLOR SIGNAL TRANSMISSION

Although an ideal signal transmission system will transmit the signal without deterioration, commercially practical systems are of necessity a compromise wherein economic factors of initial cost, operating costs and maintenance costs and also physical considerations of size, shape, weight, etc., are balanced against the degree of perfection in performance. The compromise consistent with maximum design efficiency is very frequently one in which the transmission system results in "no observable" or "no objectionable" deterioration of the transmitted signal.

A major part of video signal transmission systems are the video amplifiers. Thus it is logical to consider them individually and collectively when evaluating performance in transmission of a color video signal. In general because the chrominance components of the color signal are concentrated in the high frequency region of the signal spectrum, the amplifier characteristics in this region play a more important part in achieving satisfactory performance than is the case when a black and white signal is handled.

First, the amplitude response as a function of frequency should be essentially constant over the entire required pass band in order to avoid over or under-emphasis of the chrominance signal.

Second, the transfer linearity must be excellent. When the transfer characteristic

A. H. LIND
Manager, Audio, Projectors and Systems
Engineering Group

is not linear, the variation in incremental gain over the luminance range will directly affect the saturation of colors. Furthermore, the presence of non-linearity in the transfer characteristic is usually caused by non-linearities in tube characteristics. This condition may result in phase errors in incremental signals that will directly affect the hue of colors.

Since these deficiencies tend to be cumulative when a number of amplifiers are cascaded in a transmission system, the performance of each amplifier must be very good.

The frequency response characteristic is normally a matter of adjustment. With the video amplifier compensation networks properly aligned, performance in this respect will be satisfactory.

Since transfer linearity depends very much on tube characteristics, one might suspect that the output tube is the chief offender in contributing to the linearity deficiency. This is frequently the case. As a result of experience gained in field testing the color system, it has been concluded that, with presently available tubes, it is not feasible to design amplifiers for completely satisfactory operation at the 1.4

volt level currently in widespread use in the transmission of monochrome television signals. Nor can completely satisfactory operation be obtained from many of the existing monochrome studio equipment when transmitting a color signal at the 1.4 volt level. Thus it is recommended that the level be reduced to one-half (0.7 volt peak-to-peak composite signal) of the 1.4 volt level.

This makes the operation of monochrome equipment at the reduced level necessary if convenience and flexibility in mixed programming are to be maintained.

Existing RCA studio monochrome equipment will operate satisfactorily at the reduced level with the exception of the older TM-5 Master Monitors. In the case of the TM-5 the vertical CRO amplifier does not have sufficient gain to provide satisfactory deflection with the reduced input. However, a forthcoming RCA Technical Bulletin will describe in detail the substitution of a new cathode ray tube, the RCA 5ABP1, for the 5CP1 originally used. This change doubles the vertical CRO sensitivity of the TM-5 and thus makes it satisfactory.

Should it be necessary to supply A. T. and T. Co. network facilities a 1.4 volt peak to peak composite signal, an amplifier, such as the RCA TA-7A or modified RCA TA-5, having a gain of 2.0 and an output signal level capability of 1.4 volts can be used. Although the performance decreases as the output level is increased, the presence of only one amplifier in the studio control room system operating at this level will not perceptibly increase the distortion in the signal transmission system.

Two additional problems arise in the use of stabilizing amplifiers. The RCA TA-5 series of stabilizing amplifiers employ back porch signal clamping and also signal clipping in their sync signal processing function. Thus the clamp pulse period coincides partially with the color synchronizing signal burst, and unless steps are taken to avoid it the clamp action can badly distort the color burst. A simple, but effective, modification can be accomplished

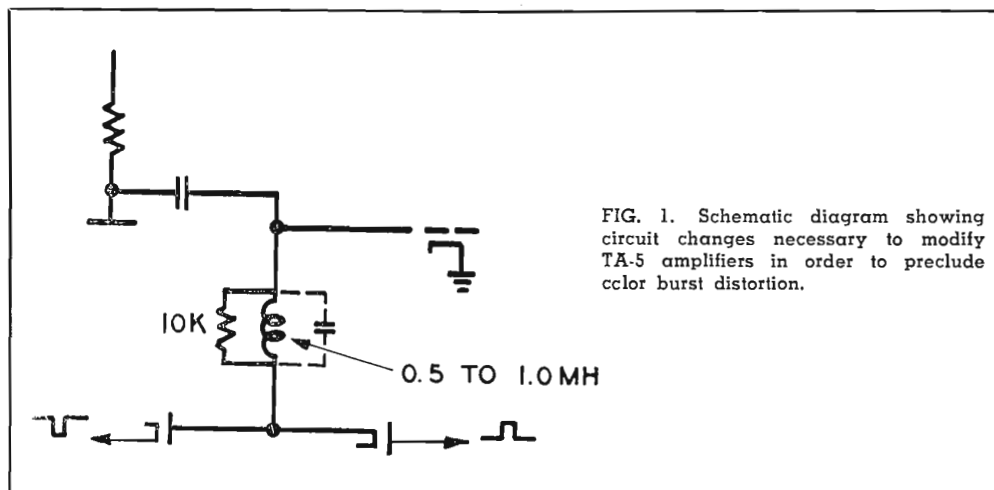

FIG. 1. Schematic diagram showing circuit changes necessary to modify TA-5 amplifiers in order to preclude color burst distortion.

on TA-5 amplifiers to preclude this color burst distortion. Fig. 1 shows the circuit changes. A filter choke chosen to have a self resonant frequency in the range of 3.5 to 4.0 megacycles is shunted by a 10K resistor to avoid spurious ringing effects and then inserted between the grid of the tube being clamped and the common connection of the clamp diodes. At low frequencies the inserted impedance is low, and thus the clamping action is affected only slightly. At the color sub-carrier frequency the impedance is relatively high which permits transmission of the burst amplitude with only very slight attenuation.

Without the addition of the impedance to isolate the clamp diodes the clamping action is frequently referred to as "hard" clamping. With the isolation present the action is referred to as "soft" clamping.

When processing the sync portion of a monochrome TV signal, it is common practice to "strip-off" or clip it at or very close to the blanking level, then regenerate it and reinsert it at a later stage in the amplifier. Similar treatment of the color signal is desirable, but greater caution must be exercised in the choice of clipping level.

The composite color TV signal as specified by the FCC Color Signal Specifications contains signal components that extend beyond blanking level in the direction of sync peaks. Fig. 2 shows a composite color bar test pattern signal for a one scanning line period. The colors in this pattern are all saturated, and thus the signal shown represents the maximum limit in peak-to-peak color picture signal that can occur. The negative peaks of the color burst extend below blanking level to a maximum of 55% of the peak of sync while the negative peaks of the sub-carrier representing saturated red and/or blue extend below blanking level to 82.5% of the peak of sync when no set-up is present in the composite signal. Thus clipping of the signal at blanking level would seriously distort the color picture information. Clipping the signal at the 82.5% of sync level would avoid interfering with sub-carrier peaks, but very frequently the clipping of sync closer to blanking level is desirable. To accomplish this the amplitude response of the video stages ahead of the clipper stage is modified to provide a 6 db attenuation at, and in the vicinity of, the sub-carrier frequency. Thus the clipping level can be set at 27.5%* of peak sync without limiting the negative peaks of the color burst or the picture sub-carrier peaks. The video

amplitude response following the clipping stage is complementary to that preceding it, thus the overall response is constant or "flat". A detailed description of the changes required to modify the TA-5B is contained in RCA Technical Bulletin Code #CJ113 and to modify the TA-5C or TA-5D is contained in RCA Technical Bulletin Code #CJ114.

A stabilizing amplifier designed specifically for color signal service is shown in Fig. 3. It is the RCA TA-7A Color Stabilizing Amplifier. Two additional new functions are available in this unit. These are a color sync or "burst" processing channel and a "white stretch" circuit. The former

makes it possible to control the amplitude and phase of color sync without affecting the remainder of the signal, and the latter makes it possible to alter the transfer characteristic of the amplifier to pre-distort the signal so as to compensate for non-

* Maximum burst amplitude within the FCC color signal specification is 110% of sync amplitude. Reducing this amplitude 6 db makes it 55% of sync and since the axis of the burst is at blanking level the peak value would be 27.5% of sync. Also, the amplitude of the sub-carrier representing saturated blue is 88% of peak white or 220% of peak sync. Reducing this signal 6 db makes it 110% of sync and since the axis of the blue component is 11% of peak white above blanking level (27.5% of peak sync) its negative peaks will also be at the 27.5% of sync level.

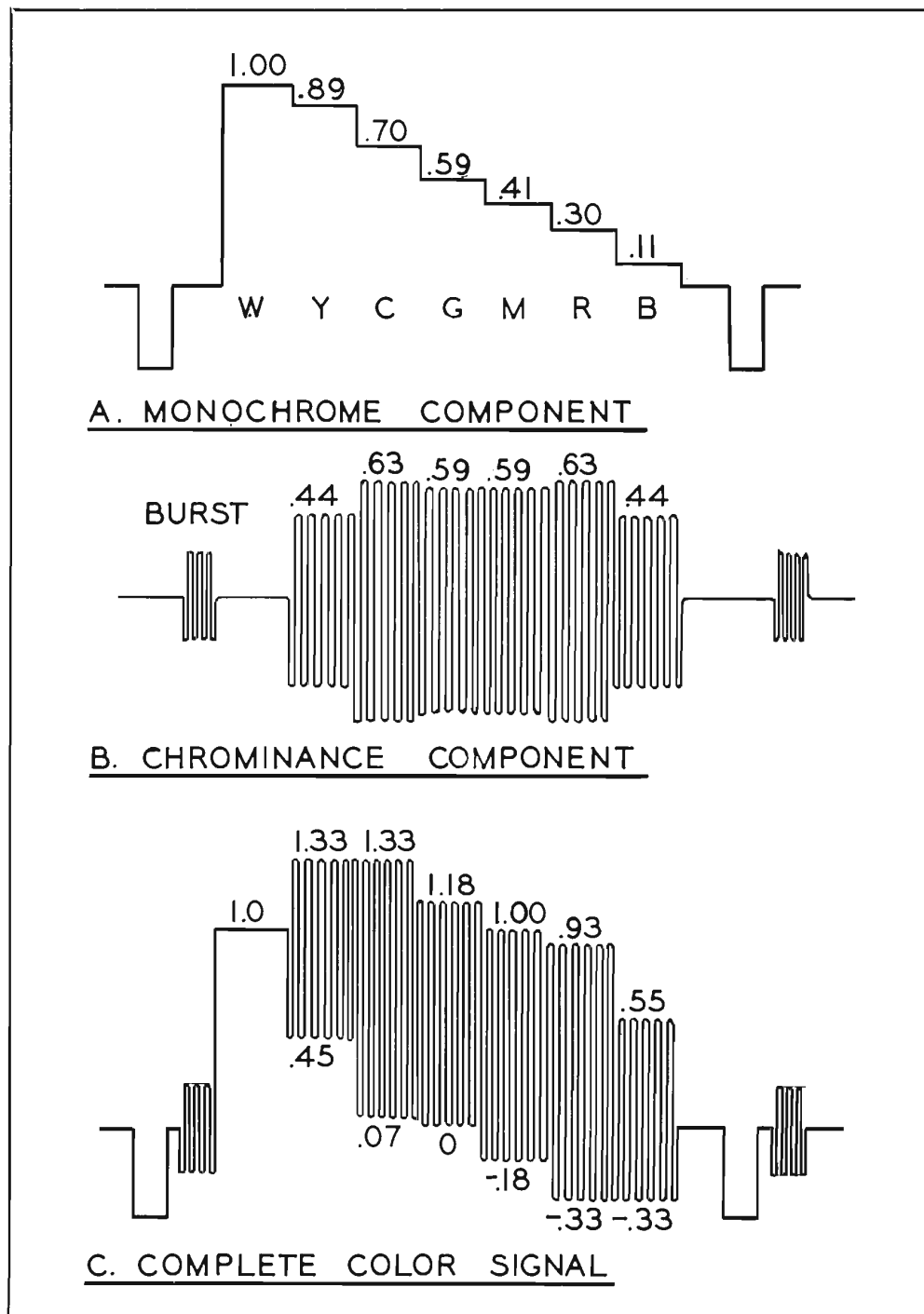

FIG. 2. Composite color bar test pattern (bottom) and its monochrome and chrominance components.

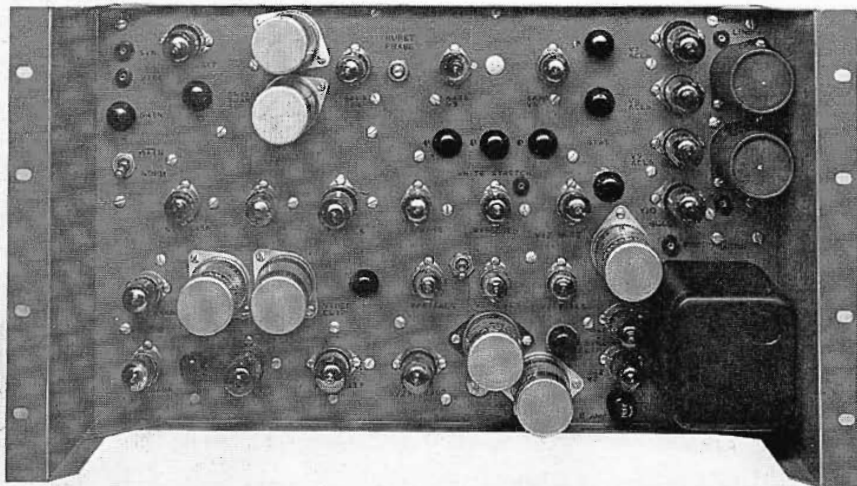

FIG. 3. RCA TA-7A Stabilizing Amplifier designed especially for color signal service.

linearity in the transfer characteristic of the transmitter.*

A block diagram of the amplifier is shown in Fig. 4. The top row of blocks indicate the color sync processing channel which bypasses the primary video channel. In this channel the phase and amplitude of the color burst can be adjusted. It is

* See "Television Transmitter Operation with Color Signals," Page 34.

then added to the primary video channel at the grids of the output stages. The primary video channel is represented by the second row of blocks. The first stage is a video amplifier preceded by gain control circuits. The second and third stages are amplifiers in which the 6 db attenuation in the sub-carrier region is obtained as well as overall nominal gain. At this point the signal path divides, and two amplifier stages in parallel are provided. One functions to stretch sync

while the other provides a non-linear transfer characteristic that is adjustable over a moderate range and designed to provide increasing gain in the direction of peak white. The signal is clamped at the tube grids in both cases since maintaining the proper d-c component in the signal is essential when non-linear operations are to be performed.

Sync stretching is accomplished by biasing the sync stretch tube so that plate current flows only during the sync portion of the composite signal. The bias setting is adjustable, thus a range of sync emphasis or stretch is possible. Since the plate current from this tube flows through a plate load impedance that is common to the white stretch tube, the additional current during the sync portion of the signal results in "stretched" sync.

The "white stretch" circuit is in parallel with the sync stretch circuit. In simplified form it is shown in Fig. 5. The plate current of this tube flows throughout the peak to peak range of the input signal into the common load impedance mentioned in the preceding paragraph. However, due to degeneration in its cathode circuit the plate current that flows for a given grid voltage can be changed by changing the amount of this degeneration. A convenient means of changing it is the biased diode network shown. When the cathode voltage becomes low enough for one of the germanium

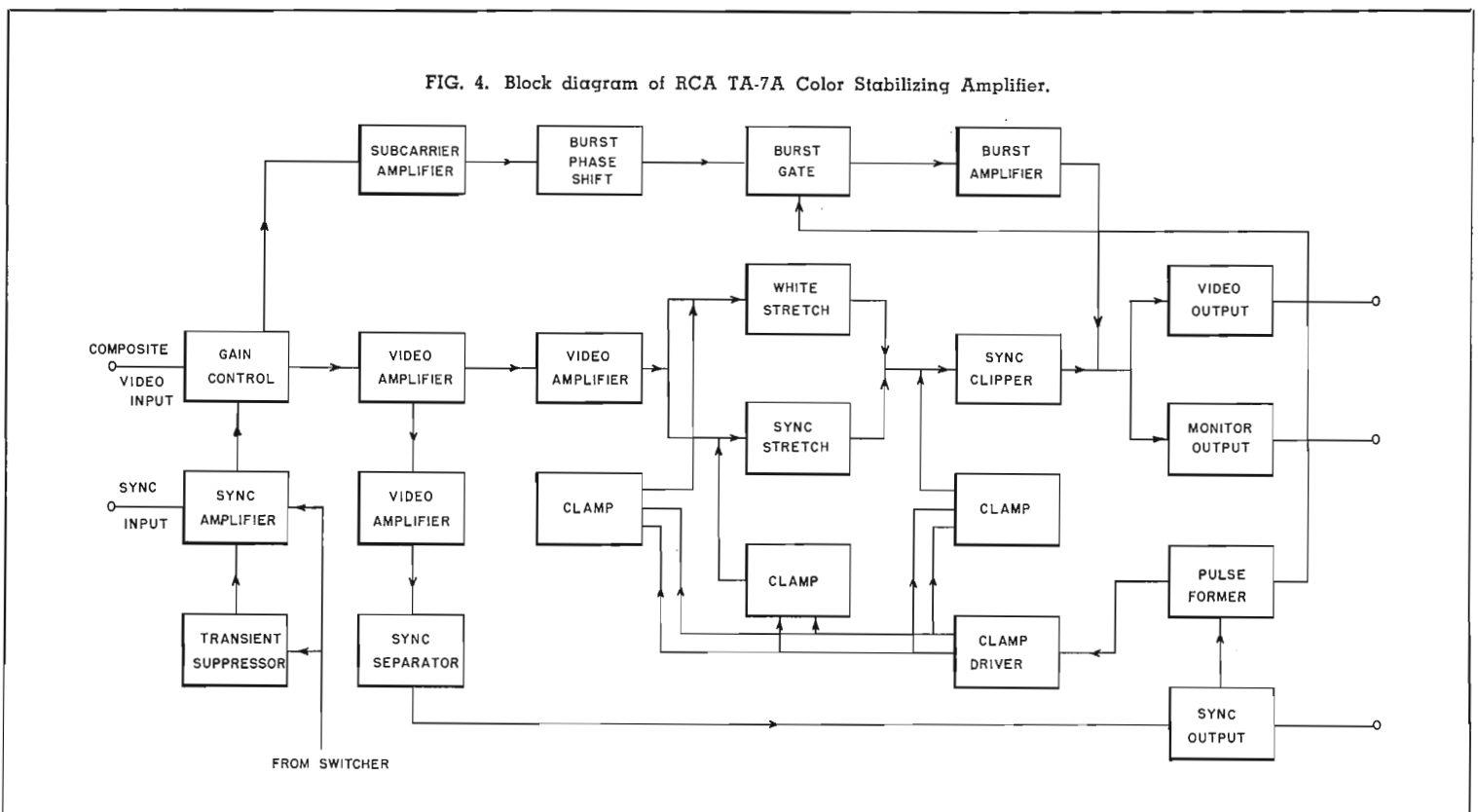

FIG. 4. Block diagram of RCA TA-7A Color Stabilizing Amplifier.

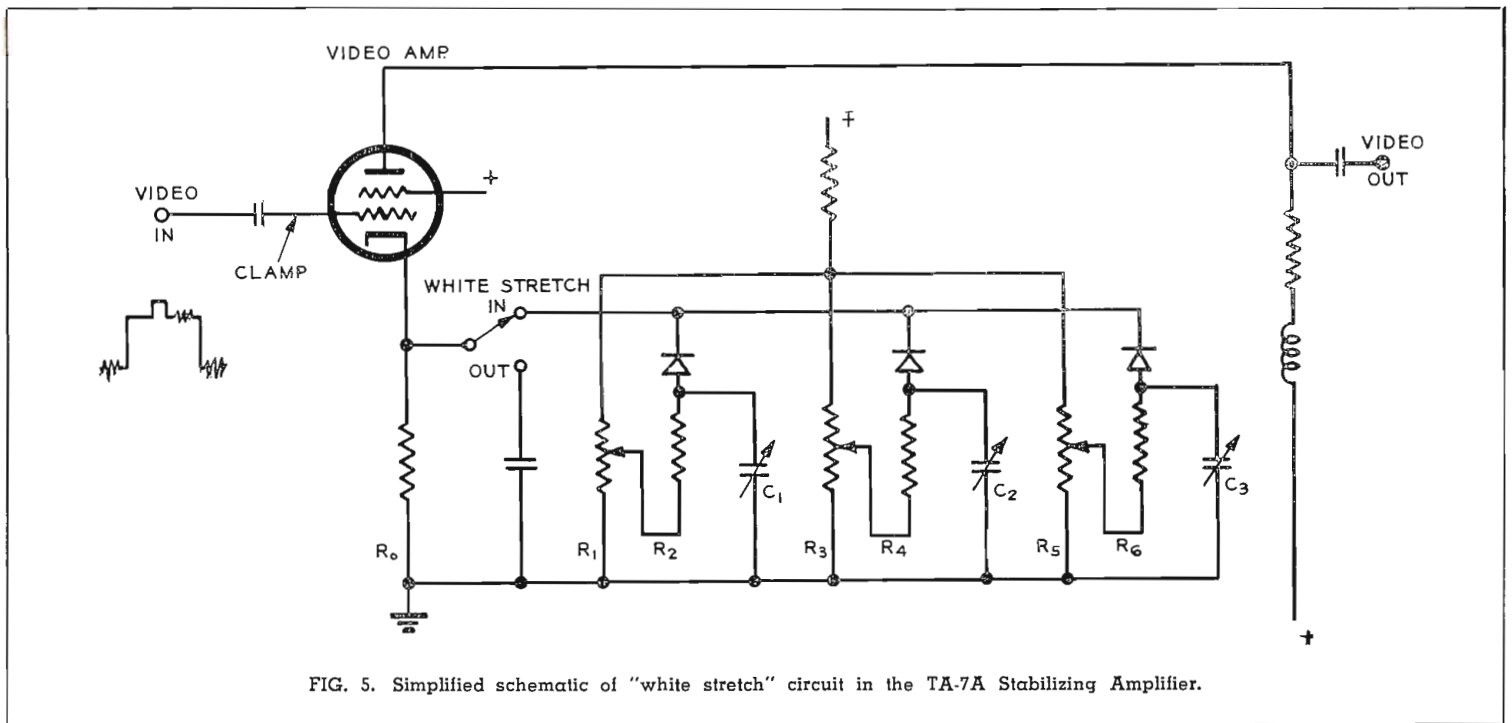

FIG. 5. Simplified schematic of "white stretch" circuit in the TA-7A Stabilizing Amplifier.

diodes to conduct, the principal cathode resistor is shunted by the forward resistance of the diode in series with the additional effective resistance to ground. Thus the degeneration is reduced and the gain of the stage is increased. The potentiometer setting establishes the cathode voltage at which diode conduction begins.

By employing three diodes and three associated potentiometers correspondingly greater versatility in the shape of the transfer or plate current vs. grid voltage curve is obtained. The grid of the tube is back porch clamped at a reference voltage corresponding to a nominally high plate current level. The grid signal polarity is white negative. As the signal goes in the white direction the plate current initially decreases rather slowly due to the high cathode degeneration. However, as the diodes successively conduct, the cathode degeneration decreases and the plate current decreases more and more rapidly; thus the white part of the signal receives the greatest amplification and is therefore "stretched" in proportion to the near black portion of the signal. The single pole-double throw switch at the cathode permits a choice between operating the stage as the non-linear "white stretch" amplifier or as a normal video amplifier.

The sync stretched and white stretched signal is next passed through a sync clipper stage which is also clamped at its grid. This stage is a sharp cut-off pentode so biased that the stretched peaks of sync in its grid signal extend beyond plate current

cut-off. The desired amplitude of sync in the output signal can be obtained by adjusting this bias by means of the Sync Clip and/or the remote sync clip controls. To the output of the sync clipper stage is added the processed color synchronizing burst from the color sync processing channel. This signal is then delivered to two output terminals by the video output amplifier stage which feeds the program line and the monitor output amplifier stage which feeds a monitor line. The program line output is sending end terminated while the output impedance of the monitor output varies as a function of the monitor output gain control setting, but is always less than 200 ohms.

The video attenuation in the subcarrier region accomplished by the stages ahead of the sync stretch and white stretch stages is recovered by accentuating the response in the clipper and output stages so as to complement the attenuation characteristic and maintain flat response for the picture signal through the primary video channel.

Provisions for adding local sync are indicated by the two blocks in the bottom left corner of the block diagram, Fig. 4. This function with its remote control is essentially the same as that used in the TA-5 series of amplifiers thus no further description is given here.

The signal path shown going vertically down from the second video stage in the primary video channel is a sync processing channel. In it sync is stripped from the

composite signal and made available at the sync output terminal. The stripped sync is used internally to generate the keying pulses for the driven clamp tubes and also the gating pulse used to gate the color sync burst through the color sync processing channel.

When the bypass channel for the burst is utilized the driven clamping accomplished at the grids of the white stretch tube, the sync stretch tube, and the sync clipper is low impedance or "hard" clamping. The burst is very much suppressed at these points because the impedance into which the preceding tube in each case works is much lower during the clamp pulse period, the stage gain being correspondingly less. This action is intentional since the intended burst path in this case is by way of the bypass channel.

An alternative mode of operation of the TA-7A is that made possible by using "soft" clamping as discussed previously having a circuit as shown in Fig. 1. This permits the burst to go through the primary video channel in which case the bypass burst channel is made inoperative by removing the burst gate tube. This latter mode of operation will probably prove to be more satisfactory in the average case because its set-up and operating adjustments are simpler and faster to make. However, the additional control offered in the bypass burst channel may make it possible to salvage more from a badly deteriorated signal than would otherwise be the case.

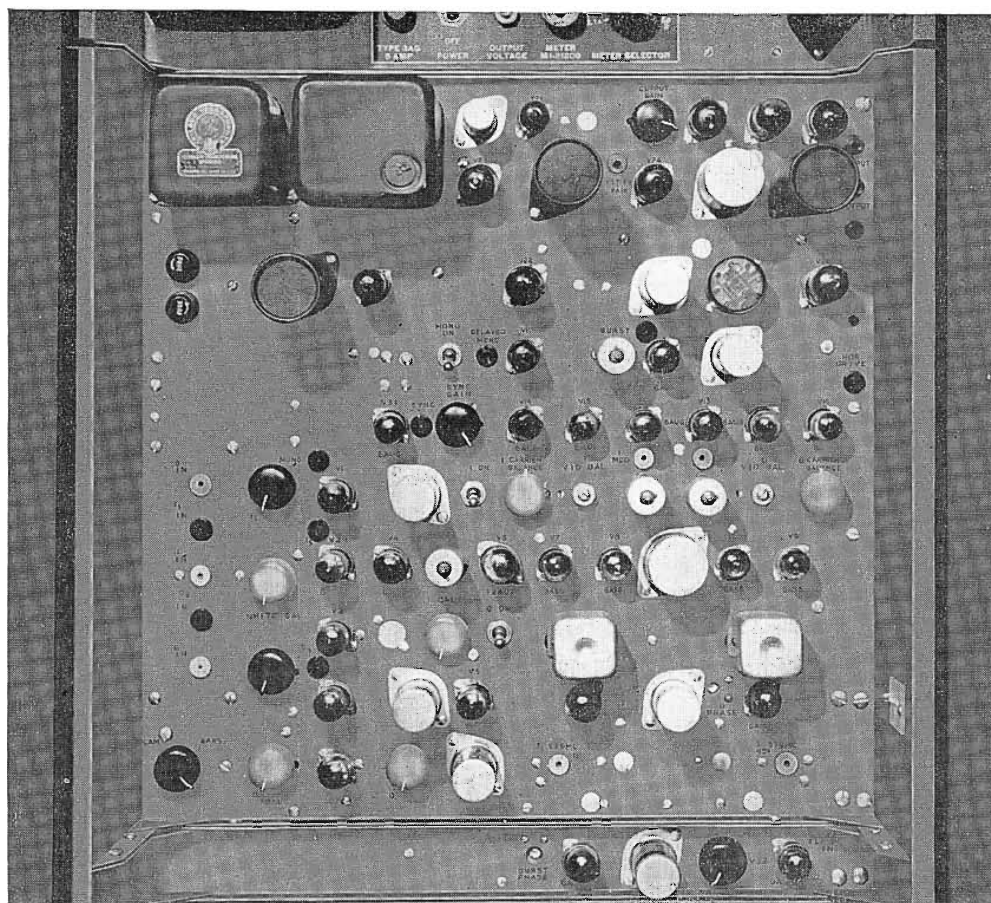

FIG. 1. Photograph of a typical RCA Colorplexer.

THE RCA COLORPLEXER

By

JOHN W. WENTWORTH

Supervisor, Advanced Development
on Color Camera Equipment

The "RCA Color Television System", Page 6, outlines and explains the basic principles of theory and operation of the RCA Color Television system with little reference to specific equipments.

From the broadcaster's point of view, the one unit which may be regarded as the "heart" of the RCA Color system is the *Colorplexer*, which performs all the matrixing and multiplexing operations necessary to process the red, green, and blue signals provided by a color camera to produce a signal conforming to the FCC signal specifications. While the basic operations performed by the Colorplexer have already been discussed and illustrated (see Fig. 26,

Page 18), some readers may appreciate a more detailed description of the actual equipment. A photograph of the Colorplexer is shown on this page.

For purposes of analysis, it is convenient to divide the Colorplexer into two sections according to the functions performed. In the matrix and filter section, shown in block diagram form in Fig. 2, the red, green, and blue signals are transformed to M, I, and Q signals which are then adjusted with respect to bandwidth and delay. In the modulator and mixer section, the multiplexing operations needed to produce one composite from the three input signals are carried out.

Fig. 2 contains relatively little new information beyond that presented in Fig. 26, Page 18, except that it shows several facilities incorporated in the Colorplexer to facilitate practical operation.

For example, a selector switch is provided at the Colorplexer input to give the operator a choice of two inputs—either camera signals or test signals from a color bar generator may be used. Note that the color bar generator provides five signals instead of the usual three. In addition to the red, green and blue video signals, special test pulses are provided which can be inserted directly into the I and Q channels by means of the circuit paths indicated in

Fig. 2. These pulses have been found to be very useful for checking the phase adjustments of the I and Q modulators.

The delay networks indicated in Fig. 2 consist of lengths of RG-65U delay cable. In the current model (MI-40200), the lengths required for the M and I channels are approximately 35 and 30 feet, respectively. Sync pulses are added to the monochrome signal prior to the delay line so as to avoid the need for a separate sync delay line.

The multiplexing operations in the Colorplexer are shown in more detail in Fig. 3 than was possible in Fig. 26, Page 18. In particular, the operation of the doubly-balanced modulators can be more clearly seen. Each doubly-balanced modulator consists of a pair of modulator tubes with push-pull inputs but a common output. The push-pull video signals are provided by a tube-type phase splitter, but a center-tapped transformer is satisfactory for the carrier inputs. The original input signals both cancel in the common output, but the product signals generated within the modulator tubes (i.e., the sidebands) reinforce each other in the output. Note that a clamp is provided to restore the DC component at the video input of each modulator; these clamps are keyed by horizontal drive pulses.

The subcarrier inputs to the doubly-balanced modulators are provided by the circuitry shown at the bottom of Fig. 3. An adjustable phase shifter with a range of more than 360 degrees is provided at the subcarrier input. The purpose of this shifter is to permit the signals from all the Colorplexers in a studio or plant installation to be "lined-up" with respect to subcarrier phase at some common point, such as the output of the switching system. Phase-shifting networks are used to provide appropriate phases for the two modulators and the burst-keyer.

The complete color signal—formed by adding the M component (with sync, if desired), the two subcarrier components, and the burst—is passed through two feedback amplifiers. The first of these provides most of the required voltage gain, and drives a low-impedance gain control. The second feedback amplifier is the output stage, which has a sufficiently low output impedance that three separate 75 ohm outputs may be connected in parallel without objectionable interaction.

The complete Colorplexer requires 22 inches of rack space, and may be powered from a standard RCA Type 580-D Power Supply.

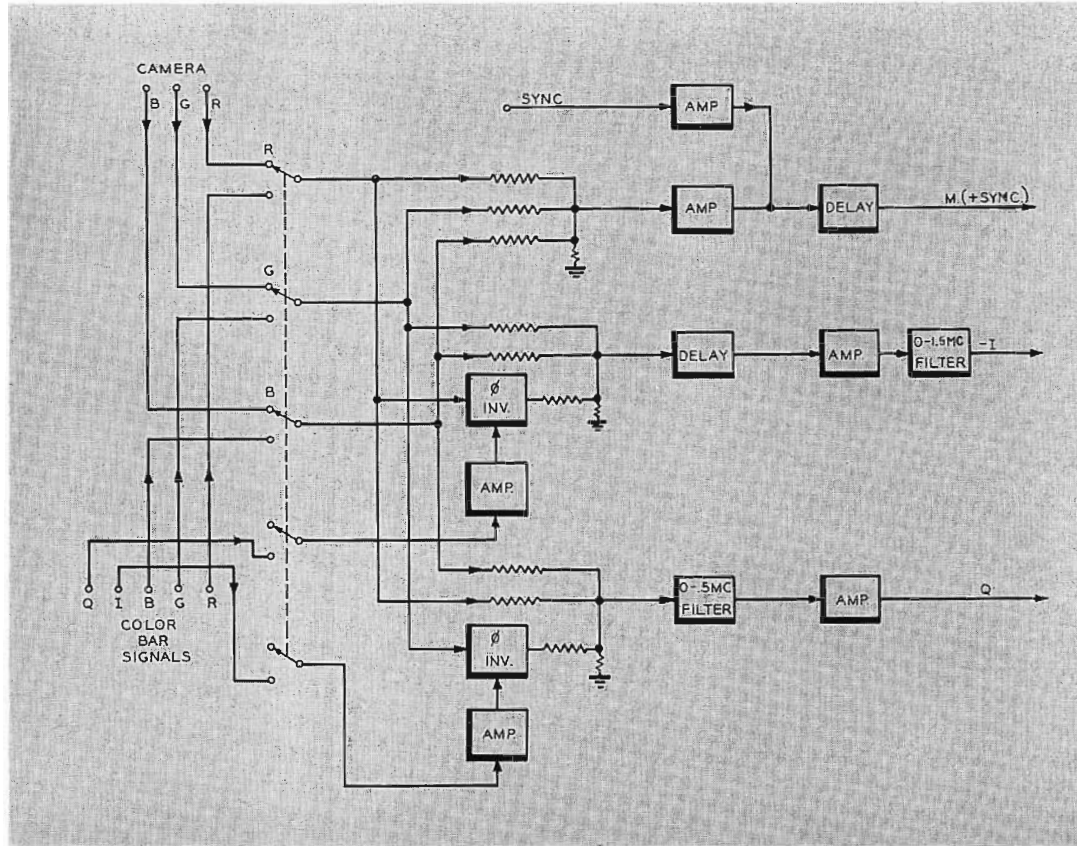
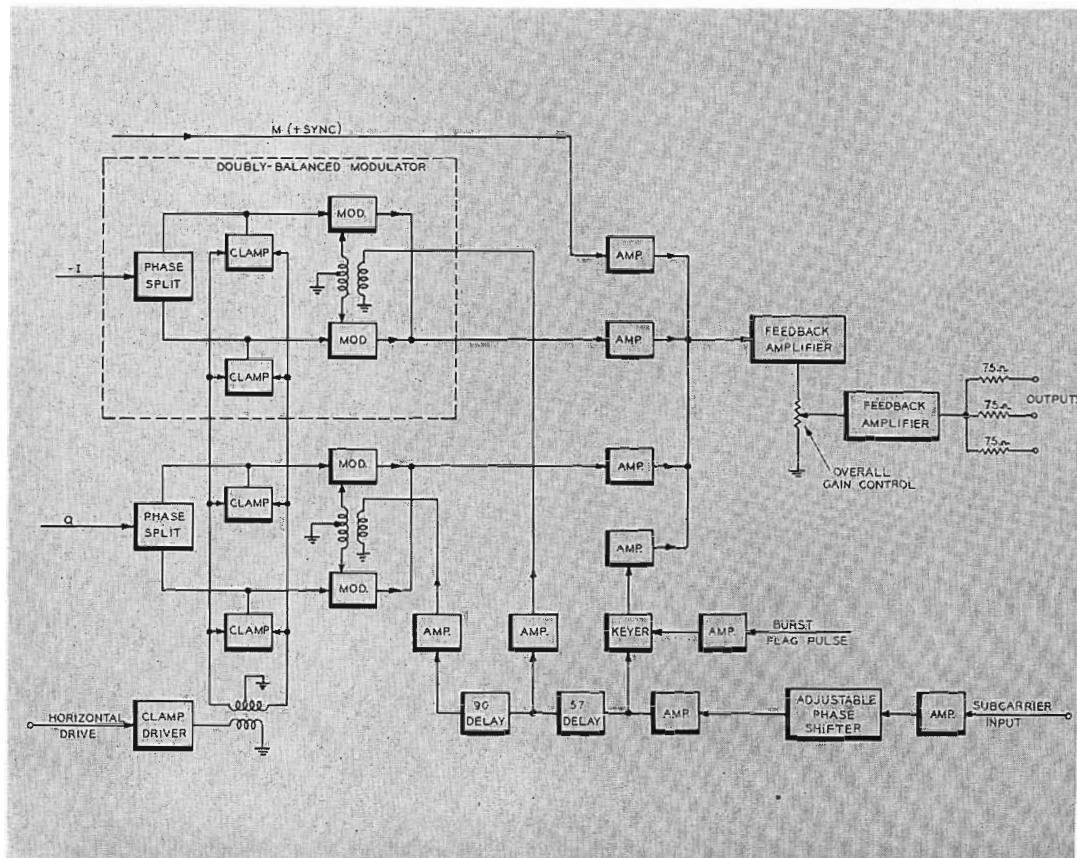

FIG. 2. Block diagram showing the matrix and filter section of Colorplexer.

FIG. 3. Block diagram for the multiplexer section of a Colorplexer.



RCA COLOR SYNC GENERATOR EQUIPMENT

When a color television program is to originate locally, it is necessary to employ local color sync generating equipment. *How to Plan for Color*, Page 20, discusses at which points in a station's development these items will be required. A description of these individual equipments, the Color Frequency Standard, modification of the TG-1A Synchronizing Generator and the Burst Flag Generator, follows:

Color Frequency Standard

One of the requirements of basic importance in the RCA color television system is a highly stable source of color subcarrier frequency signal. The FCC Color Signal Specifications specify that this frequency of 3.579545 mc be held to within ± 0.0003 percent and have a maximum rate of change not to exceed 1/10 cycle per second per second. The RCA Color Frequency Standard is a unit designed to fulfill these requirements. In addition it performs a second function in developing a signal of a frequency which is a sub multiple of the subcarrier frequency by the ratio of 455/4. The desirability of establishing frequency interlacing of the luminance and chrominance harmonic signal clusters is discussed on Page 11. Further consideration of possible visible beat patterns resulting from the chrominance subcarrier and the sound carrier beating together has resulted in the FCC specification choice that the frequency separation of the picture and sound carriers be an even multiple of one-half

By **A. H. LIND**

Manager, Audio, Projectors and Systems Engineering Group

the line frequency and similarly the frequency separation between the color subcarrier and the sound carrier to be an odd multiple of one-half the line frequency which assures frequency interlace in both cases. The numbers chosen define the frequency separation between picture and sound carriers (4.5 mc) as being the 286th harmonic of the line frequency and the color subcarrier frequency as the 455th harmonic of one-half the line frequency.

The RCA Color Frequency Standard is illustrated in Fig. 1. A functional block diagram of the unit is shown in Fig. 2. The subcarrier frequency is generated in a crystal controlled oscillator which uses a slightly modified AT-cut quartz crystal in an RCA TMV-129N crystal oven to exceed the minimum required stability. A buffer stage follows the oscillator stage. Out of the buffer is available the subcarrier for use where required in the color studio system and also as the input signal to a frequency divider channel which divides the subcarrier frequency by 455/4. The output of the frequency divider channel is thus approximately 31.5 kilocycles which may be used to lock the master oscillator in a TG-1A Synchronizing Generator, and thus insure the proper ratio between the subcarrier and line frequencies. The frequency

divider channel consists of a locked oscillator stage operating at 1/5 the frequency of its input signal followed by a locked oscillator stage operating at 1/7 the frequency of its input signal. The next stage is a frequency multiplying stage which quadruples its input signal. The fourth stage is a synchronized, cathode-coupled, LC stabilized multivibrator operating at 1/13 of its input frequency. The product of these ratios is the desired 4/455 multiplication (or 455/4 division) ratio. The signal resulting from the frequency divider channel action is passed through a buffer amplifier stage the output of which is connected to the sync generator.

Burst Flag Generator

The subcarrier output of the Color Frequency Standard is utilized in the RCA Colorplexer (see Page 48) in two ways. One application is in the I signal and Q signal modulators. The second is the addition of the color subcarrier burst which is added to the picture signal during the "back porch" period for the purpose of color synchronization in receivers. This burst of signal is added to the picture signal by means of a gated mixing stage which is controlled by an external gating signal generally referred to as the "burst flag" pulse. Such a "burst flag" pulse source is the RCA MI-40202 Burst Flag Generator. A front view of this cabinet rack mounting, bath-tub chassis type of unit is shown in Fig. 3. A block diagram of the generator is

FIG. 1. The Color Frequency Standard, a highly stable source of color subcarrier frequency signal.

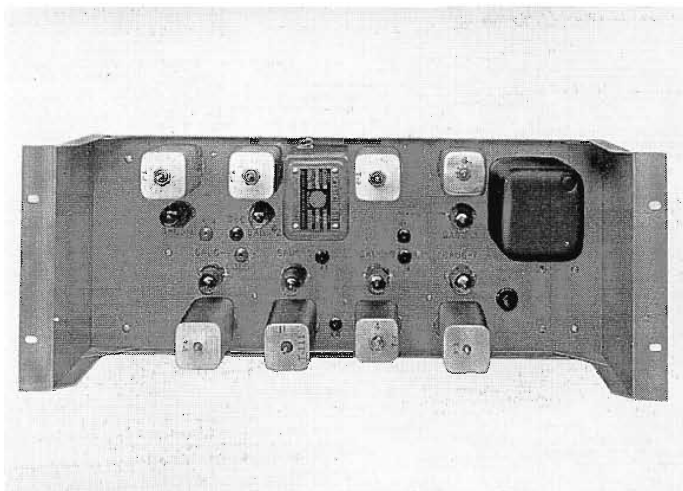
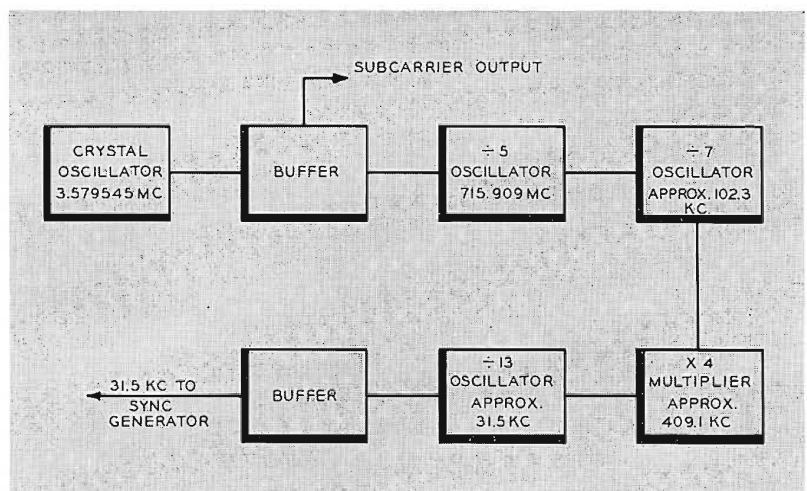

FIG. 2. Simplified block diagram showing the functions of the RCA Color Frequency Standard.



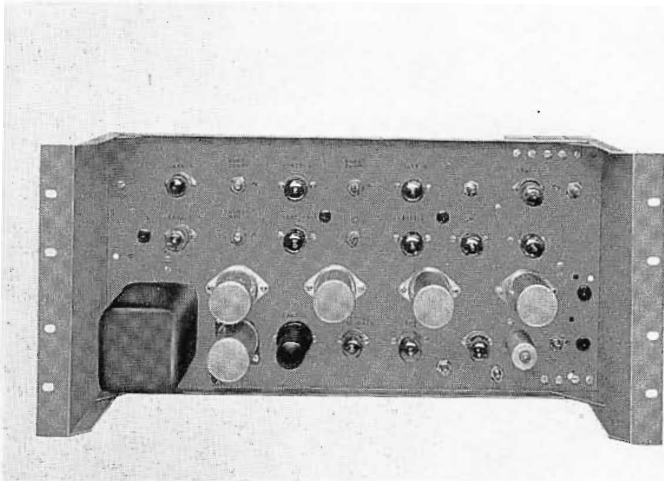

FIG. 3. Burst Flag Generator, the external gating signal pulse source.

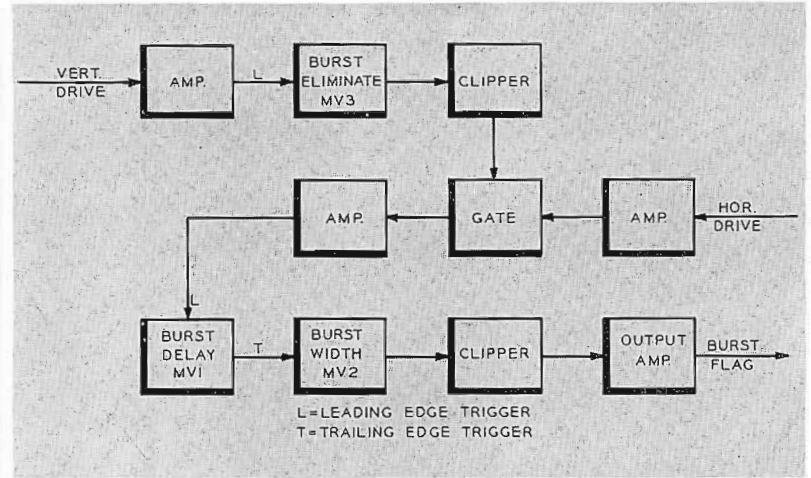

FIG. 4. Block diagram showing the functions of the Burst Flag Generator.

shown in Fig. 4. Basic timing information from the sync generator is required in the form of horizontal and vertical drive signals. Since the total peak-to-peak amplitude of the composite color signal would be increased if subcarrier bursts were added to the signal during the vertical sync period*, the generation of burst flag pulses is interrupted during this interval. Elimination of these pulses is accomplished by gating out the nine horizontal drive pulses during the equalizing pulse and vertical sync intervals with a proper duration 60 cycle pulse generated in the Burst Eliminate multivibrator which is in turn triggered from vertical drive. The remaining horizontal drive pulses trigger the Burst Delay multivibrator which generates a pulse that is adjustable in duration. The trailing edge of this pulse is used to trigger the Burst Width multivibrator which generates a pulse that is also adjustable in duration. This pulse after being clipped becomes the output "burst flag" pulse. The burst delay multivibrator establishes the timing of the start of the subcarrier burst with respect to the leading edge of horizontal drive while the burst width multivibrator establishes the number of cycles of subcarrier contained in the burst.

Modification of TG-1A Synchronizing Generator

In order to utilize the 31.5 kilocycle output of the color frequency standard conveniently, a slight modification of the TG-1A Sync Generator is made. Fig. 5

*The leading edges of vertical sync pulses correspond in relative timing to the leading edges of horizontal sync pulses. However, the duration of the vertical sync pulses is about five times that of the horizontal sync pulses. Thus subcarrier bursts which are timed to closely follow horizontal sync pulses for "back porch" positioning on the composite signal would add to the peak of vertical sync pulses should they be allowed to occur during the vertical sync interval.

shows a schematic diagram of the portion of the circuit affected. The circuit shown is that existing after the modification. The picture diagram shows the relative locations of the major components involved. A coax receptacle mounting bracket, a coax receptacle, two resistors, a small mica capacitor and a test pin jack are the only components added. The circuit change consists, for the most part, of rewiring switch S1 so as to introduce the 31.5 kc signal from the frequency standard into the master oscillator in switch position number 3. Terminal number 3 of switch section I is disconnected from the external sync line to connector J1 and then connected to ground. Thus the reactance tube control grid is returned to ground when color TV operation is used. Switch section II is re-

wired to open the cathode circuit of the internal 94.5 kc crystal oscillator tube in the first three switch positions and close it in the fourth, which insures that the internal crystal oscillator is inoperative on all but the internal crystal position of the switch. Switch section III, previously unused, is wired so as to connect the master oscillator tube grid (pin 4 of V11) to the 31.5 kc frequency standard input circuit in position number 3 and to the internal crystal oscillator circuit on the other three switch positions. To complete the modification a test pin jack mounted close to the master oscillator tube socket on the chassis is connected to the output plate of V11 by means of a small coupling capacitor which makes checking of the oscillator synchronization a convenient matter.

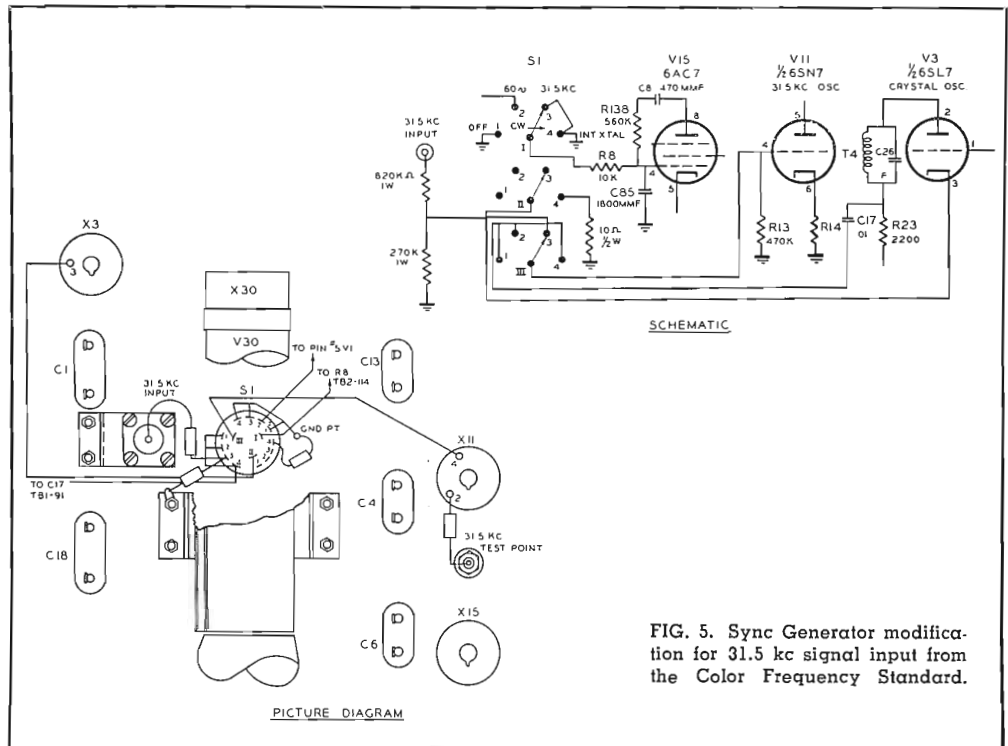

FIG. 5. Sync Generator modification for 31.5 kc signal input from the Color Frequency Standard.



FIG. 1. The above system, with the Color Slide Camera shown in the foreground, has been supplied to laboratories for color receiver testing. The third tall rack from the left contains a three-Kinescope monitor. To the right of this cabinet is a rack-mounted master monitor, push button panel and Color Slide Camera Remote Control Panel. Adjacent racks house the sync generator equipment, gamma amplifier, colorplexer, decoder and power supplies. For broadcast service, these racks of equipment (less the three-tube monitor and the rack-mounted master monitor) are supplied as accessories.

RCA COLOR SLIDE CAMERA, TK-4A

The Color Slide Camera converts the information on a color transparency into three separate video signals proportional to the red, blue and green components of the transparency. This type of reproduction is capable of high resolution and inherently perfect registration of the three video signals and is also suitable for reproducing color movies when used in conjunction with a fast pull-down or continuous projector mechanism.

Color Slide Camera Components

The block diagram in Fig. 2 shows the essential components of the Color Slide

by **W. E. TUCKER**
Supervisor, Color Slide Camera
Design Engineering

and **F. J. JANDA**
Development Design Engineer,
Color Slide Camera

Camera. These components, except for the gamma amplifier, constitute the Color Slide Camera unit. The Kinescope, with its associated deflection chassis and 27 KV power supply, provides the light which passes through a lens to the color trans-

parency. Color separation is accomplished in the pick-up unit where the color intensity variations are transformed into color video signals. The units which follow amplify and modify these signals so that they are proper for operating a simultaneous monitor or for feeding a colorplexer for eventual transmission.

The light-source Kinescope is a specially designed 5-inch flat faced tube (see Fig. 4). In order to perform satisfactorily as the light source, the spot must be small, the phosphor must have sufficient light output covering the entire visible spectrum

(see Fig. 9A) and it must also have an extremely short persistence. The phosphor is specially screened so that any visible grain structure is extremely small and uniform. The gun alignment must be extremely accurate in order that the electron beam be circular, of small diameter and require minimum electrical centering. The ultor (second anode) voltage is 27 KV and the first anode voltage is about 6 KV. The beam current of the Kinescope is about 200 micro-amperes and is limited by phosphor saturation and focusing ability.

A cover over the Kinescope is provided for protection from X-rays and high voltage. An interlock turns off the high voltage when the hinged cover is opened. The Kinescope raster can be viewed through an X-ray glass window in the front of the cover when it is closed.

The 27 kilovolt ultor voltage for the Kinescope is produced by an R.F. type regulated supply (Fig. 5). It is capable of at least 750 μ a output at 27 KV and also supplies the first anode voltage through a high resistance bleeder and focusing potentiometer. The high voltage oscillator operates at a frequency of about 75 KC and a voltage doubler rectifier circuit increases the high voltage to its required level. The entire supply is contained in a removable copper-plated housing which minimizes R.F. radiation from the oscillator. Finger type contacts provide good contact between the cover and chassis.

A course focus control is provided on the front panel of the supply while a fine adjustment is located on a remote control panel.

Fig. 6 shows the deflection chassis. Special features of this chassis provide for both horizontal and vertical deflection circuits which are capable of excellent linearity as in the case of any high quality camera device. Only a very small amount of defocusing can be allowed in the corners of the raster. Appreciable defocusing in addition to causing poor corner focus would also cause improper shading because a slightly defocused beam produces higher light output when the phosphor is operated near its saturation point. A blanking signal is developed on this chassis and is applied to the Kinescope grid to cut the beam off during the retrace interval. The control panel on this chassis contains size, centering, beam current control and a provision for metering the high voltage and beam current. Another provision is an electronic protection circuit which cuts the Kinescope off in the event of loss of either horizontal or vertical deflection, thus protecting it against phosphor burns.

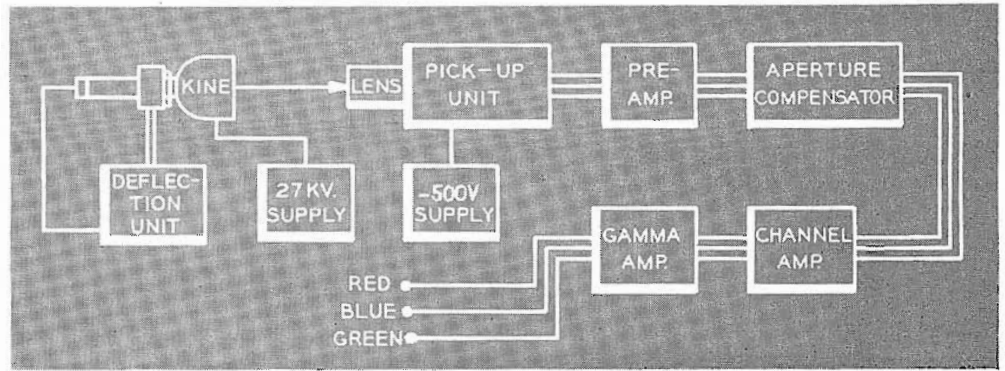

FIG. 2. Color Slide Camera unit diagram.

The deflection chassis is of the rack mounting type and, together with the 27 KV supply, is operated from a WP33B 280 volt power supply. Input signals required are horizontal and vertical drive and blanking. Two Twinax cables carry the deflection signals to the yoke on the Kinescope.

The actual optical assembly is shown in Fig. 8. For purposes of discussion Fig. 7 illustrates the optical parts in the pick-up unit. The blank raster which is produced on the Kinescope (A) is sharply focused by the objective lens (B) on a color transparency (C). The condenser lens (D) is located so that its focal point coincides with the exit pupil of the objective lens thus rendering the light rays parallel. Since color is a property of light involving 3

variables, it can be separated into its primary components (Red, Blue and Green) by means of the color selective dichroic mirrors (E, J). The separated primary components are condensed by lenses (G, K, N) which image the exit pupil of the objective on the photo cathodes of 3 photo-multiplier pickup tubes (I, P, M). The photo multipliers thus receive varying intensity of light as the spot of light scans the color transparency; the raster itself being completely out of focus. The photo-multiplier tube outputs are the required simultaneous color video signals which are amplified and processed similar to monochrome video.

The spectral sensitivity of each channel in the Color Slide Camera is adjusted to closely match the theoretical sensitivity

FIG. 3. Color Slide Camera front view.

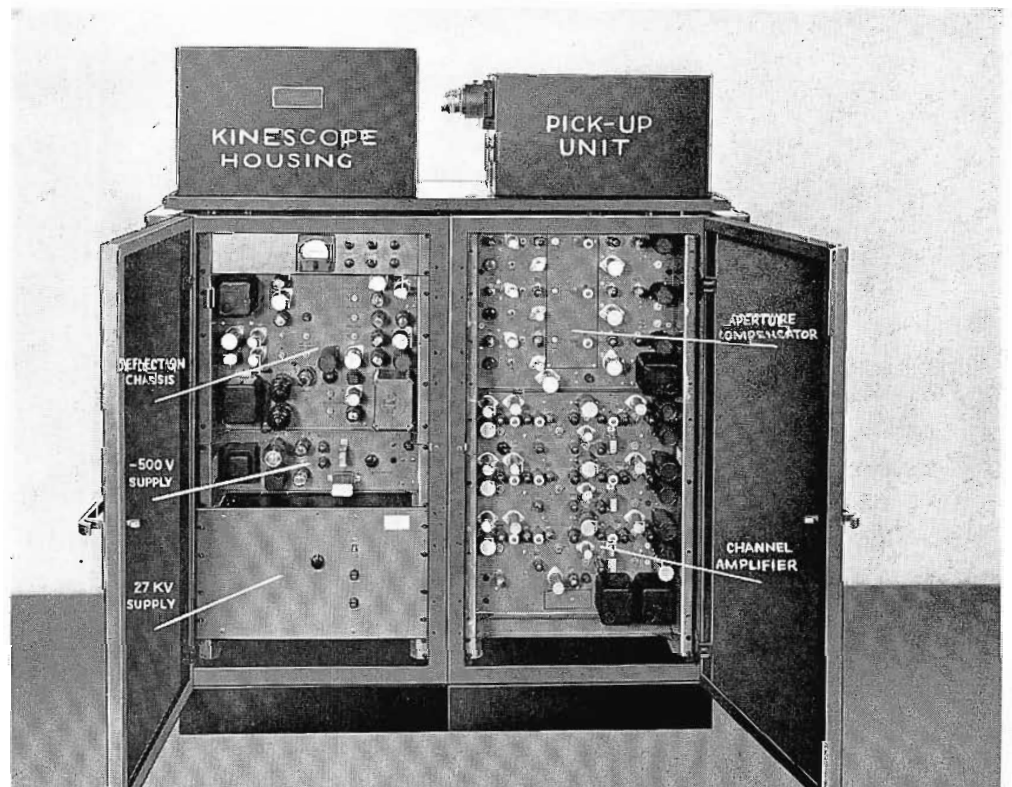

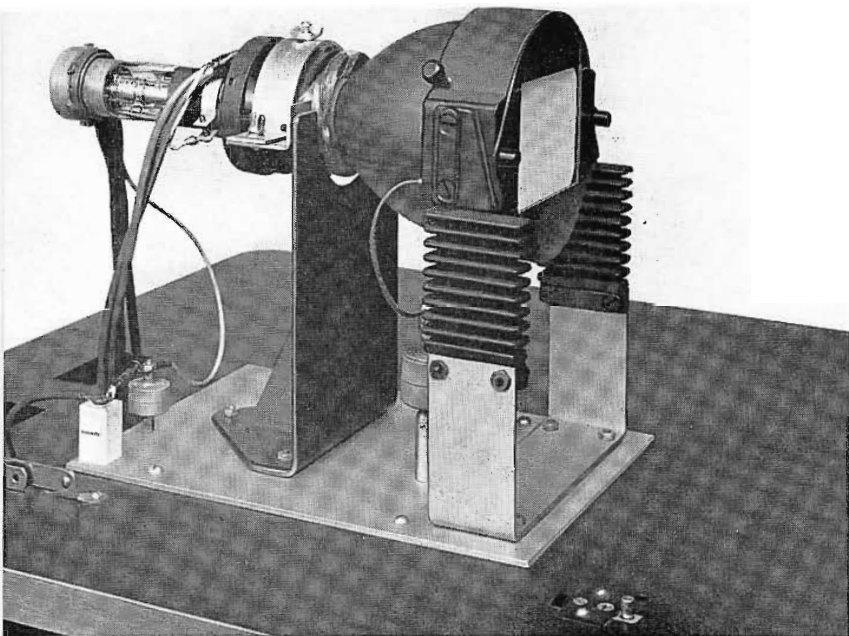

FIG. 4. Kinescope and mounting. Kinescope is used as light source for scanning slide transparency. See Fig. 7 for Kinescope position in relation to overall system.

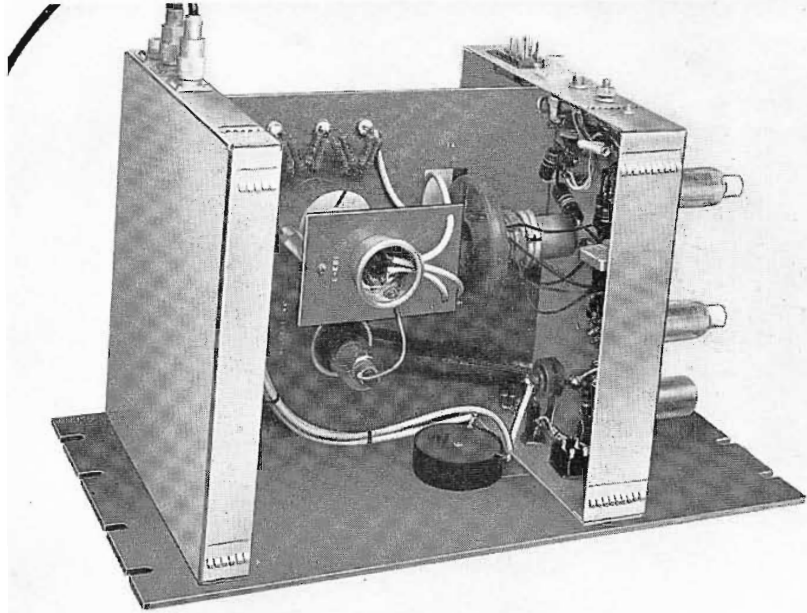

FIG. 5. 27-KV Power Supply used to furnish focusing and Ultor voltages (second anode voltage) for camera kinescope.

curves required for perfect color reproduction. The shapes of the primary spectral curves for 3 color channels are determined by the chromaticities of the RCA tri-color Kinescope phosphors. The relative amplitudes of the 3 curves (Fig. 10B) depends on the sizes of the units in which the primary colors are measured. These amplitudes (i.e., the relative sensitivities of the three channels) are readily adjusted by means of gain controls for the photo multiplier tubes.

In determining the spectral sensitivity of each color channel in the pick-up unit

prior to correction by trimming filters, it is necessary to consider the spectral distribution curve of the Kinescope phosphor as well as the spectral reflection characteristics of the dichroic mirrors and the inherent sensitivity curves of the photocells. Spectral characteristics of the Kinescope phosphor, photocells and dichroic mirrors are shown in Figs. 9A, 9B and 9C respectively. (Transmission curves for the dichroic mirrors are obtained by subtracting the reflection curves from 100%.)

Fig. 10A shows the sensitivity curves that result when these characteristics are

properly multiplied together for the three channels. The filters marked H, L and O in Fig. 7 are used to modify the spectral response curves to the shapes shown in Fig. 10B; these curves closely approximate the ideal curves required for good color reproduction.

The dichroic mirrors function by means of the interference phenomena of light. A thin dichroic coating is evaporated on optically flat glass, the thickness of coating and angle of incidence determining the spectral response; i.e., which colors will be passed and which ones reflected. Both mirrors in the unit are placed 45 degrees to the angle of incident light with a 45 degree silvered mirror (F) Fig. 7, used merely to condense the space the optics and photomultipliers occupy. The mirrors are nearly 100% efficient; that is the light that is not reflected is transmitted and a negligible amount is lost by absorption. To prevent multiple internal reflection within the mirrors the back sides are low-reflection coated.

The photomultipliers are the head-on variety. RCA 5819 type tubes are used in the green and blue channels while the RCA 6217 type is used in the red. A -500 volt regulated supply (Fig. 3) in addition to the standard +280 volts from the pre-amplifier power supply provides voltages for the 10 photomultiplier dynodes. Individual photomultiplier gain is accomplished by controlling the #4 and #5 dynode voltages. An f/1.9 50 mm Ektar objective lens is used. Variations in overall slide densities are compensated for with the iris in this lens.

Remote Control Panel

Remote adjustment of iris, photomultiplier gains, pedestal, and fine Kinescope

FIG. 6. Deflection chassis. Provides horizontal and vertical sawtooth currents and blanking signal. Knobs on Control Panel provide raster size, centering and beam current.

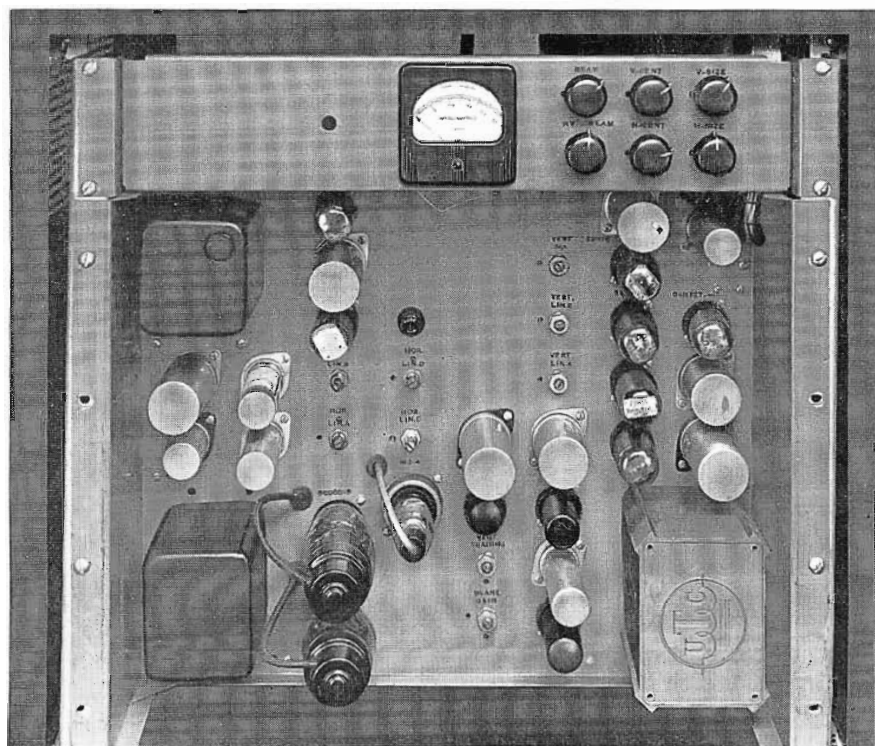

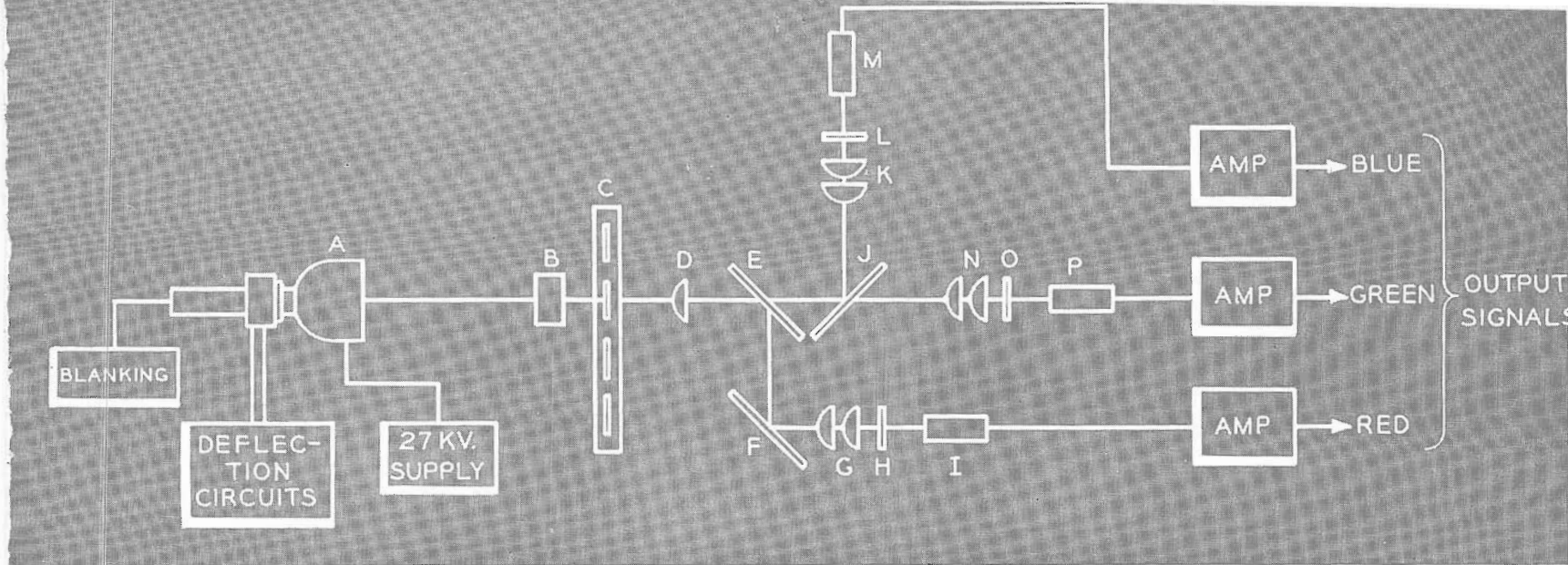

FIG. 7. Diagram showing elements comprising the slide camera optical system as illustrated in Figs. 4 and 8. Complete optical system is contained in the two table-top housings of Fig. 3.

focus are provided on a "remote control panel" located at the control console. This panel (Fig. 1) can also be rack mounted with the addition of a rack adapter. A push button switching system is necessary for level adjustment of the red, blue and green video signals with a provision for viewing each color individually on an RCA Master Monitor, MI-26136-A. There are several spare switching inputs to monitor other signals.

The Preamplifier

The preamplifier is shown in Fig. 8, upper right, partially hidden.

The photomultiplier output of .05 volt peak-to-peak signal is amplified to 0.2 volt

peak-to-peak in the preamplifier. Three identical channels use 6AK5 input tubes for low microphonics and high gain followed by a 6AH6 video amplifier. The output stage is a 5763 tube feeding a 51 ohm coaxial cable which carries the video to the next unit. The frequency response is flat to 8 MC corresponding to 640 lines resolution.

Each channel of the preamplifier contains 2 variable high peaking circuits to compensate for phosphor decay time. In an ideal system only one spot of the subject would be illuminated at a given instant by the Kinescope. However, practical phosphors although having extremely short persistence must always have a finite decay time so that each part of the screen con-

tinues to emit light in accordance with an exponential decay curve for an appreciable time after the scanning spot has passed. Thus the photocell output is not an instantaneous function of the transmission of the slide transparency from point to point.

Finite phosphor decay-time produces an effect similar to that of a low pass filter resulting in a loss of the high frequency response. This effect on a square wave is shown in Fig. 11.

Frequency compensation is accomplished in the first two stages of the preamplifier by using cathode peaking. Controls are provided to adjust the amount of compensation at both the low and middle range of the video spectrum.

FIG. 8. Pick-up unit. Consisting of objective lens, slide holder, dichroic-mirrors, condensing lenses, corrective filters, multipliers and preamp (partially hidden—upper right).

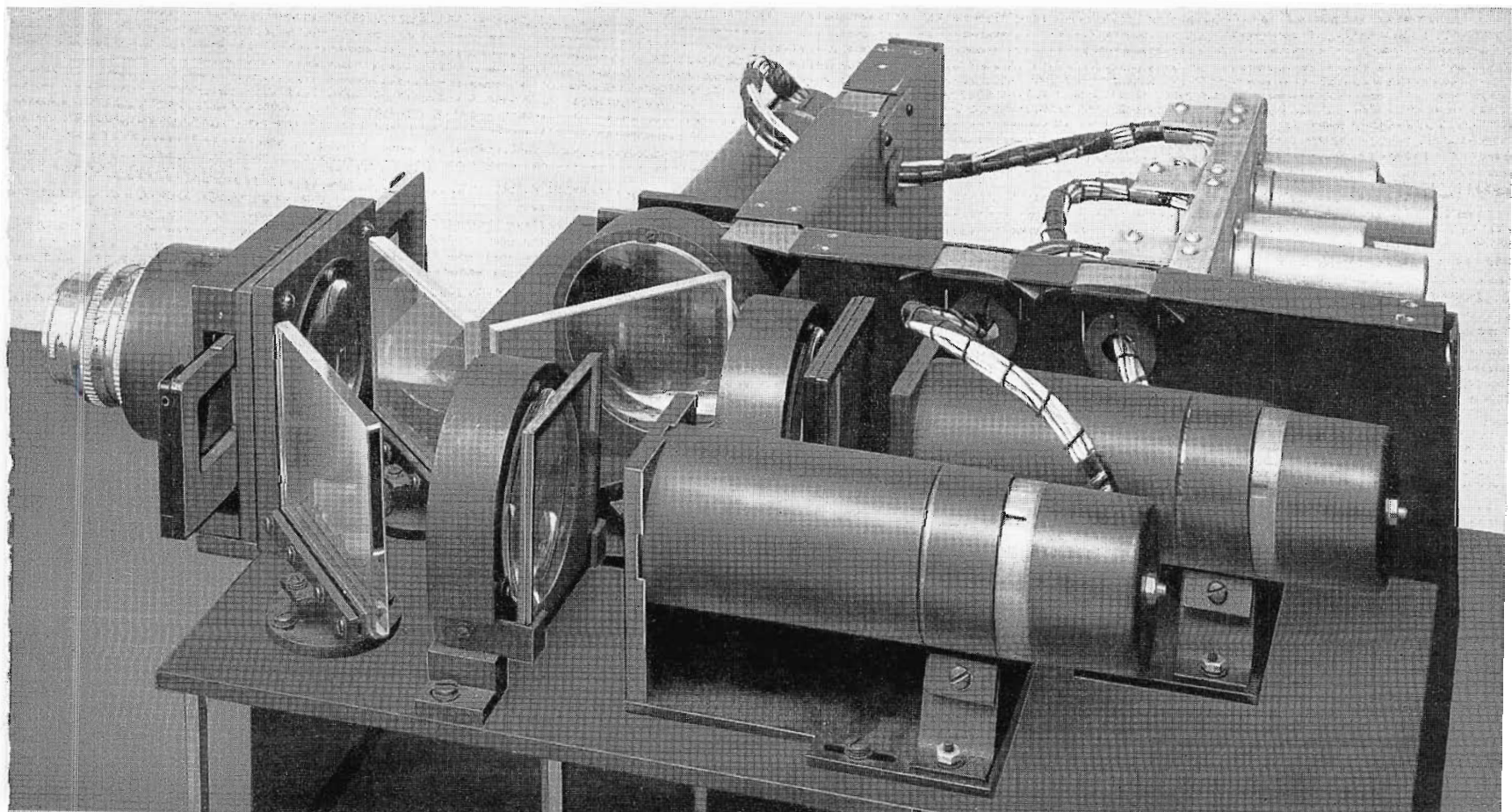

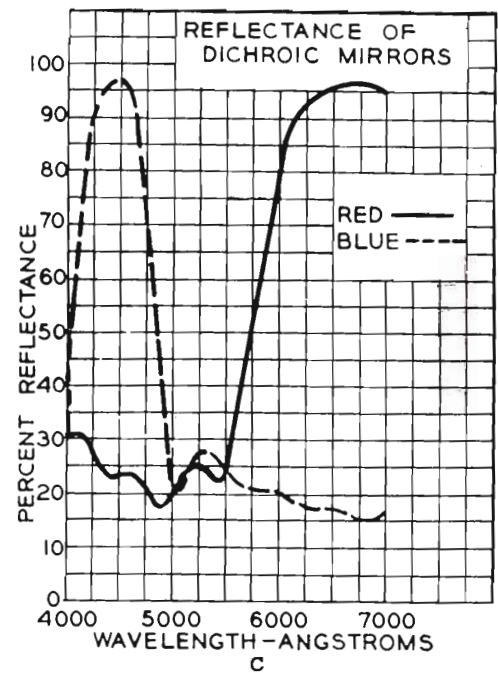
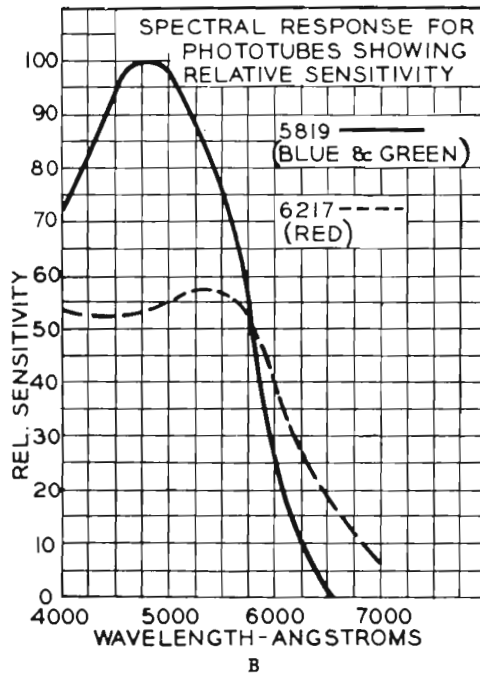
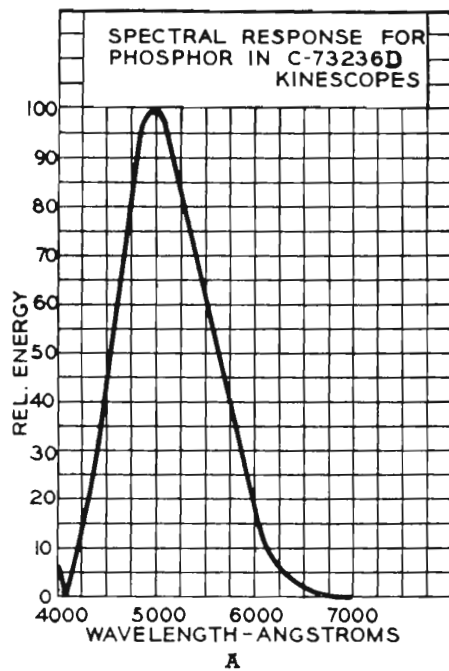

FIGS. 9A, B and C. Spectral response curves.

The preamplifier and the aperture compensator, discussed below, are powered by one WP-33B power supply.

Aperture Compensator

The video signals from the preamplifier are cabled to the aperture compensator (Fig. 13). This unit is designed to correct high frequency video information which is lost by virtue of the finite scanning beam size. The effect of a finite aperture in the slide camera is similar to inserting a low-pass filter in the video channel. Attenuation and phase shift also depend on the cross-sectional shape of the scanning beam and electron density distribution.

The aperture compensator must be restricted to a device which modifies the frequency response, yet maintains a constant or linear phase characteristic with frequency. Ordinary transmission lines fall into this category, but a lumped constant delay line of several sections is a very close approximation. A dispersionless line, designed to have an electrical length of one-half wavelength at 9 MC, is used. The sending end of the line is terminated in its characteristic impedance, while the receiving end is left open. The effective frequency response at the receiving end of the line is flat, but the response at the sending end follows a cosine law because of the reflection from the far end. Video signals from each end of the line are fed to a differential amplifier to produce a difference signal that follows a cosine law with minimum gain at low frequencies and a maximum gain at 9 MC. A maximum boost of about 10:1 is available with the peak

occurring at about 9 MC. Two concentric pots act as a boost control, keeping the low frequency video constant.

With the aperture compensator in the circuit the video response of the slide camera can be made flat within 10% to 4 MC (corresponding to 320 lines resolution) in the center portion of the picture. Without aperture correction the response is down about 60% at 4 MC. By use of the aperture compensator the "limiting" resolution is extended to better than 600 lines. The unit contains four tubes per channel and is on a standard 19-inch rack mounting chassis. The frequency response is flat to 8 MC without correction and a feedback amplifier capable of terminating the sending end of a 51 ohm line is used for the output stage. The aperture compensator has unity gain and is designed to operate at a signal level of 0.25 volt peak-to-peak.

The Channel Amplifier

The next step in processing the color signal is to clamp, add blanking, clip and amplify to a standard RMA 1.0 volt peak-to-peak level. These operations are standard in any of the monochrome live pick-up or film camera equipment and are executed in this unit in the conventional manner. The channel amplifier has 3 identical channels with 2 video outputs per channel. An input gain control is provided in each channel and the output stages have gain controls to balance each to the same level. A four-position input switch provides for selection of a green signal to all 3 channels, standard operation and 2 test signals which are necessary in setting up the equipment. Pedestal adjustments are provided

on the chassis to adjust the tracking of the pedestal controls on the remote control panel. One overall and three separate pedestal adjustments are provided.

The circuitry of a similar type of Channel Amplifier is thoroughly described in the article "RCA Color Camera Chain" by F. W. Millspaugh, Page 68.

Gamma Amplifier

This unit (Fig. 14) is not located in the Color Slide Camera 42-inch racks, but it is very necessary in the production of a correct color picture. It is a unity gain gradient corrector commonly known as a gamma amplifier. The problem of gradient (or gamma) correction in color TV systems is more important than in monochrome. Non-linearities produce distortions in the gray scale or tone rendition of a monochrome picture, but both luminance (brightness) and chromaticity (color) distortions are introduced in the color process. The overall gradient of the Color Slide Camera is linear, the photocell output being linear with illumination and the video amplifiers are high quality linear devices. The RCA tri-color Kinescope has a static transfer characteristic that closely follows a 2.2 power law for each color. A non-linear amplifier must therefore be used in the Color Slide Camera chain in each channel to compensate for the transfer characteristic of the color Kinescope (Fig. 12).

The gamma amplifier essentially provides the inverse transfer characteristic of the tri-color Kinescope by changing its gain at three different video levels; the blacks and dark grays of the picture receiving greater amplification than the peak whites. This

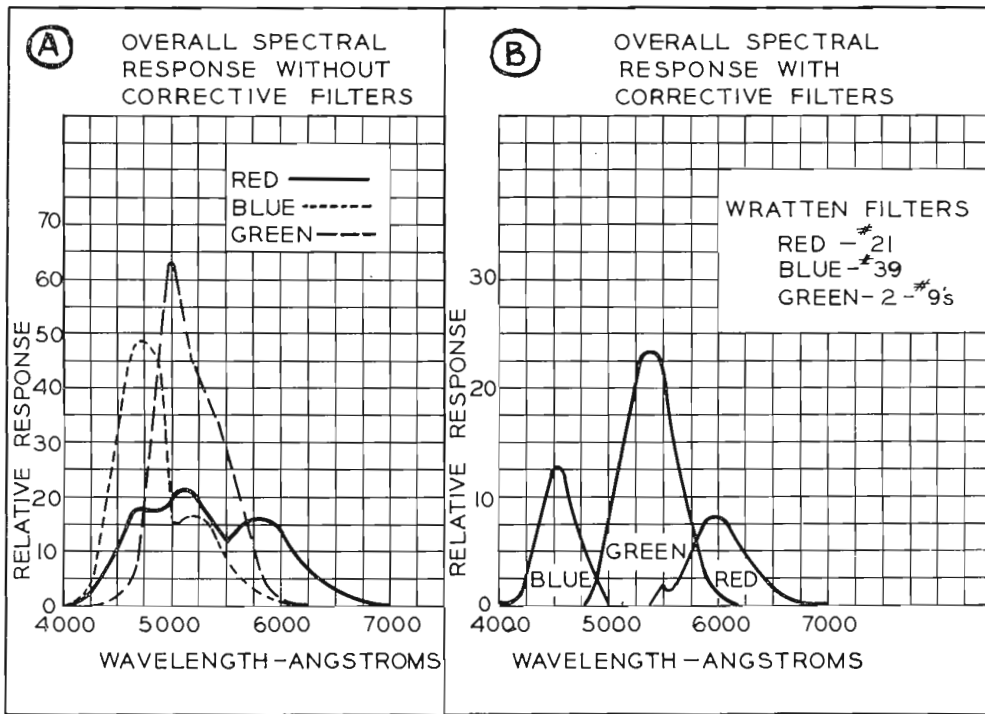

FIGS. 10A and B. Overall spectral response curves.

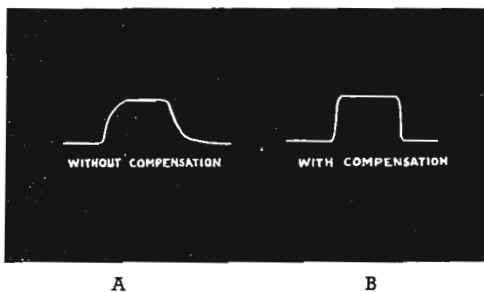

FIG. 11. Waveforms showing the effect of phosphor decay time. A, without compensation. B, with compensation.

operation is accomplished by controlling the cathode impedance and hence the gain of a video amplifier by means of germanium crystals each one of which conducts and

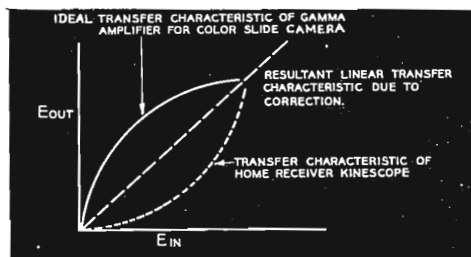

FIG. 12. Gamma curves.

shunts the cathode degeneration resistor at a different video level.

The gamma amplifier is on a 19-inch rack mounting chassis and is operated from a standard WP-33B power supply. Two

outputs, as in the case of the channel amplifier, are provided in each channel. The frequency response is essentially flat to 8.0 MC and the correction is variable from a power law of 2.0 to 2.5. The color signal can be viewed on a simultaneous monitor from one set of outputs while the others feed the colorplexer (described below).

Auxiliary Equipment

To obtain a complete color picture signal certain equipment is necessary. This equipment, which is common to the color television system, is briefly mentioned below.

The required sync signals are horizontal and vertical drive, RMA sync and blanking. These signals are obtained from a standard sync generator which is not 60-cycle controlled but is controlled by the 3.579545 MC frequency standard which counts down to a 31.5 KC signal; this signal is then used to synchronize the sync generator.

In order to produce a composite signal the three simultaneous signals must be fed to the colorplexer where the signals are "coded" and burst is added. The burst signal of 3.579545 MC comes from the frequency standard and is keyed into 9-cycle groups, at a horizontal line rate, by the burst flag generator. The burst is added in the horizontal blanking interval following the sync pulse. Sync can be added in the colorplexer or if desired delayed sync can be added after video switching.

Black-and-white monitoring equipment is required to set individual color levels and to check the colorplexer signal. A color monitor is necessary to view the line signal. This picture is equivalent to that on a color TV receiver.

FIG. 13 (below). Aperture Compensator. Serves to restore high-frequency video information—providing greater picture detail.

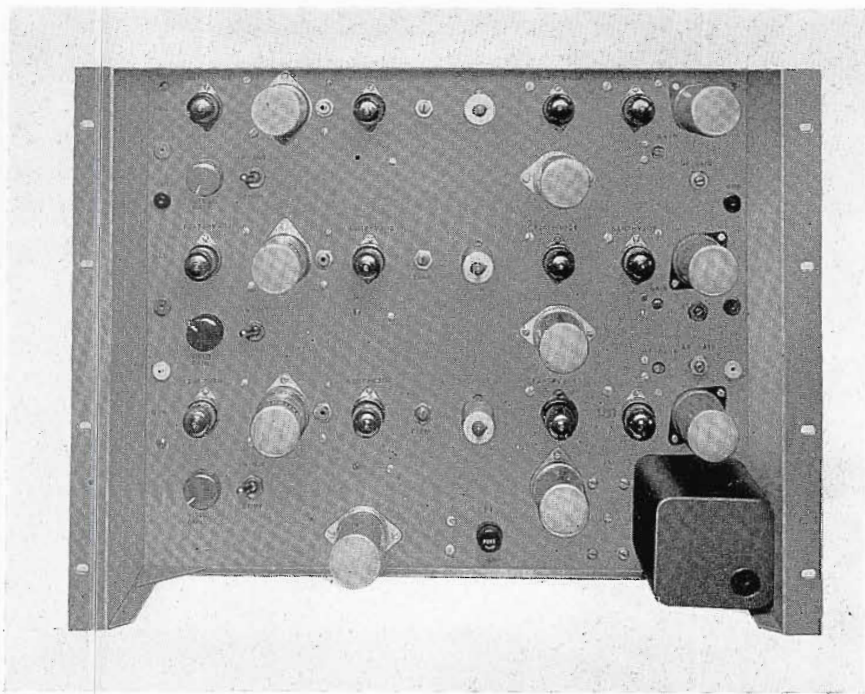
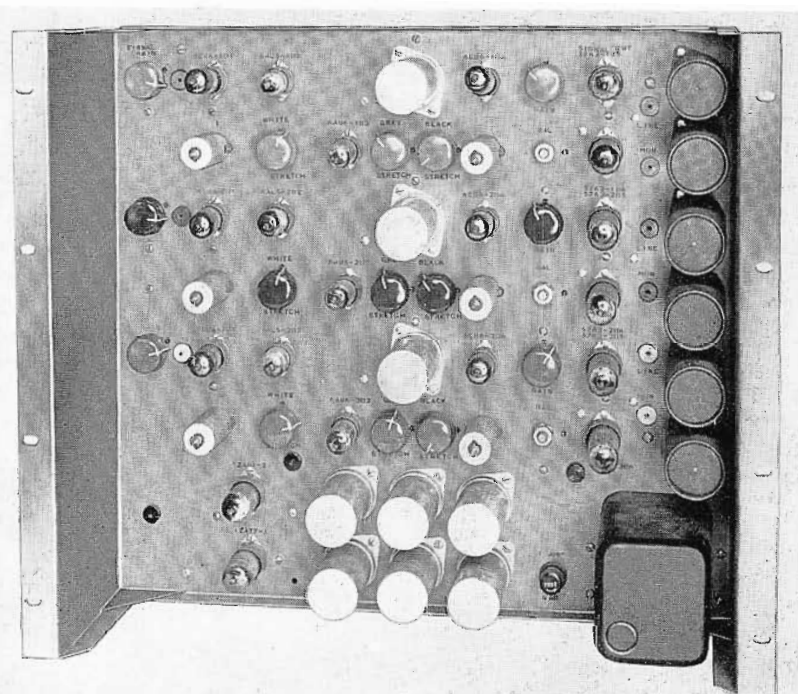

FIG. 14. Gamma Amplifier. A non-linear amplifier used to correct the video signals for the non-linear characteristics of the receiver kinescope.



FILM EQUIPMENT FOR COLOR TV APPLICATIONS

RCA COLOR FILM CAMERA, TK-25A

By W. J. POCH

Manager,
Broadcast Studio Engineering Section

Films are expected to play the same important part in color programming that they do in monochrome. Moreover, because of the added impact of products shown in color, advertisers are likely to insist on color film "commercials" at an early date. Recognizing this, RCA engineers have been working for several years on the development of a suitable color film chain.

Possible Film Systems

There are some half dozen different ways in which a color film chain could be built. In order to be sure that we were selecting the most practical for the purpose, all of these were carefully considered. The three most likely systems were tested at length, and were demonstrated for a group of broadcast consulting engineers on October 29, 1953. These were:

(1) *A Three-Vidicon Camera With Standard Projector*

This system employs a camera which uses three Vidicons with a light-splitting optical system similar to that used in the live Studio (Image Orthicon) Camera (see Page 62). Although the sensitivity of the Vidicon is too low for studio use, it is entirely sufficient for film pickup. The great advantage of this system is that it can be used with a standard monochrome projector such as the Type 6A. Also it can be multiplexed very easily. For good results it is necessary to have three Vidicons with well-matched characteristics.

(2) *A Flying Spot Scanner With Continuous Motion Film Projector*

This system uses, as a source of illumination, a "flying spot" generated by a kinescope scanner similar to that used in the RCA Color Slide Chain (see Page 52). A special type of projector moves the film at a constant velocity and employs an optical system of rotating elements which compensate for the motion of the film in such a way that a stationary image is obtained. This system, which was developed in

Europe before the war, has the advantage of being easy on the film. However, it is extremely difficult to eliminate objectionable vertical motion and image flicker due to light variations. In general it gives satisfactory quality only when provided with elaborate mechanical compensating systems (such as servo-mechanisms) to control film positioning and light output.

(3) *A Flying Spot Scanner With Fast Pull-Down Projector*

This system also uses the kinescope-type flying spot scanner, but in this case the projector is similar to the standard type used in monochrome except that it is designed to pull the film down (from frame-to-frame) in approximately 1.3 milliseconds. At this speed the whole movement is completed during the vertical blanking period. Thus, by the time the scanning beam has retraced its path to the top of the raster, a new frame is in place. In principle, this is the simplest of all systems, and it enables use of a very simple electronic pickup system consisting of three photo-cells. Its disadvantage is that the mechanical pull-down system must be very carefully designed to avoid film breakdown.

Production Plans

Of the three systems described above, the combination of the fast pull-down projector and flying spot scanner is the most advanced. A model of this equipment was completed nearly a year ago, and subjected to extensive laboratory tests. Subsequently this model was sent to NBC where it has been in use for several months. Operation has been quite satisfactory. Although careful film handling is necessary, the pictures produced with this equipment have been of excellent quality. Based on this experience production was started on this type of equipment some months ago. Deliveries to stations which have already ordered color film equipment, will begin in May.

Meantime, progress on the development of the 3-Vidicon Camera has been rapid.



FIG. 1. The 16mm fast pull-down projector console complete with associated color flying spot scanner, video pre-amplifier, deflection amplifier, and high voltage power supply.

A very satisfactory model has been developed and demonstrated to groups of industry engineers. Without exception these engineers have been enthusiastic about the advantages of this film system. At the same time increased production of Vidicons has made it evident that obtaining matched sets of tubes will be feasible in the near future. As a result of these favorable developments production has been started on 3-V (3-Vidicon) cameras for delivery early this fall. These cameras may be used with the RCA Type 6A Professional Projector (slightly modified) which is already being used for monochrome by many stations. This combination will have the advantage of using a projector of proved design. In addition it will be easy to multiplex, so that systems using several projectors will be simpler than with the flying spot camera systems.

(Editor's Note: The color film system which is described below is the fast pull-down type which, as noted above, will be the first to be delivered. In a future issue of BROADCAST NEWS we will have an article describing the new 3-V Film Camera System.)

Design of the Fast Pull-Down Projector

The major difference between a fast pull-down projector and a standard monochrome projector is the speed with which the film is pulled down from one frame to the next. In a conventional monochrome television film scanning system the light pulse is applied only during the vertical blanking interval and the scanning of the electron image on the sensitive surface of the pickup tube is accomplished while the surface is completely in darkness. Storage of the image is therefore an essential characteristic of this method of operation. It was recognized for years that operation in the reverse manner would have certain advantages since light could then be applied

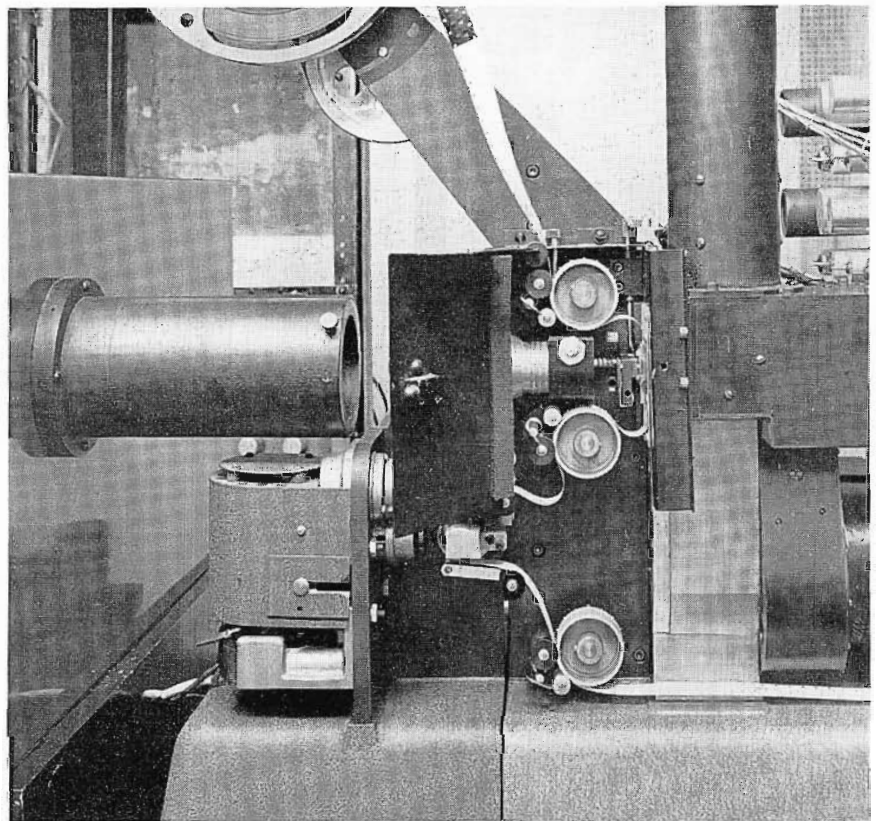
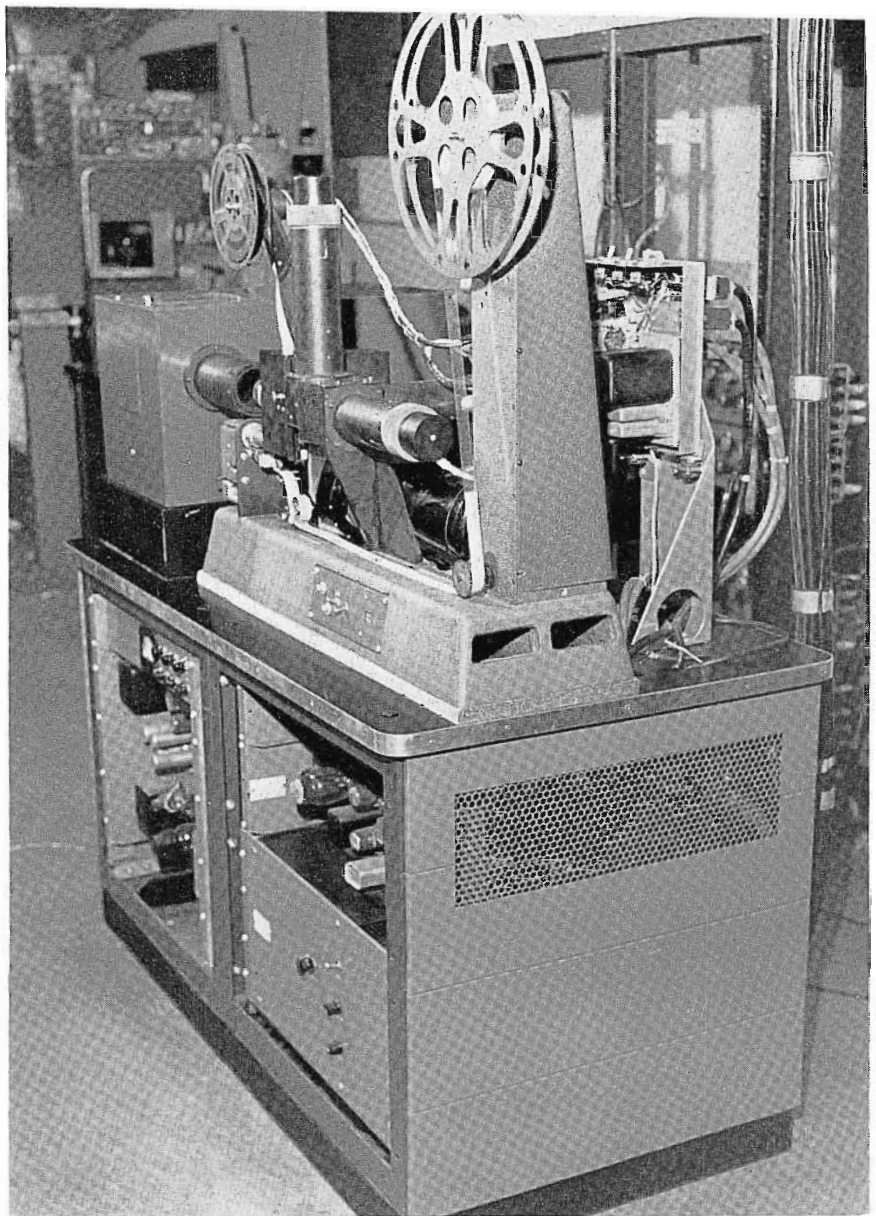

FIG. 2. Closeup of the 16mm fast pull-down projector showing details of the film path.

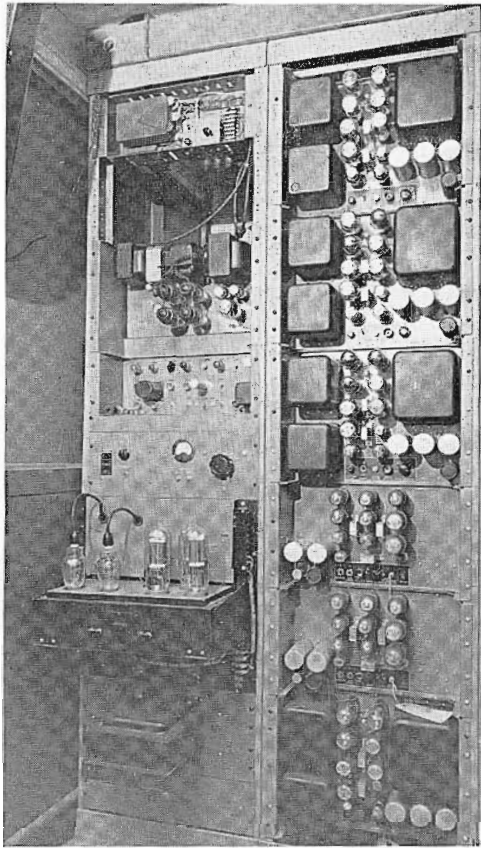

FIG. 3. View of the power supplies used for the fast pull-down projector equipment. Rack at left supplies power to the projector motor.

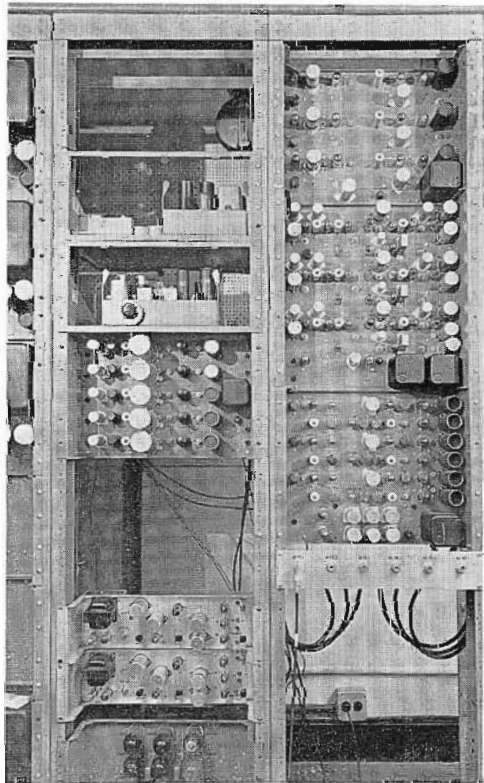

FIG. 4. View of the "rack-mounted" electronic control equipment for the fast pull-down projector. The left hand rack contains audio amplifiers and video distribution facilities, while the right hand rack contains the aperture compensator, control amplifier, and gamma corrector.

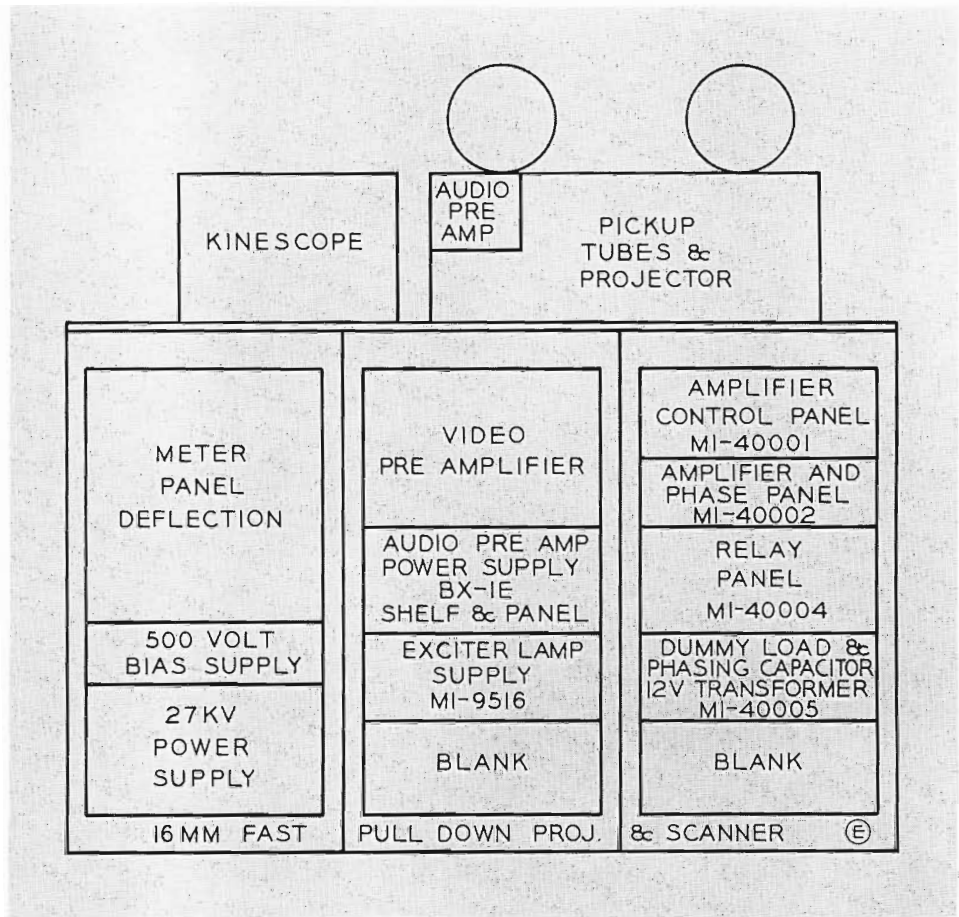

FIG. 5. Diagram of the console of the fast pull-down projector showing arrangement of the various components.

during the entire scanning period provided film pulldown from one frame to the next could be accomplished during the vertical blanking period. This arrangement is particularly suitable for use with a flying spot scanner since a given frame of film will remain stationary in the projector film gate while the beam on the flying spot tube is scanning a complete raster. The major problem involved with this system is the rapid motion required for moving the film from one frame to the next during the period allowed by the duration of vertical blanking. This period is approximately 1.3 milliseconds which is four or five times faster than the normal pulldown period associated with a 16mm machine. While this presents an extremely difficult mechanical problem, we believe that it has been solved successfully in a machine designed by our advanced development group and put into operation early last year. This machine together with the associated flying spot scanner is now in regular use at NBC in New York. Excellent results have been obtained.

The intermittent mechanism for this machine was designed with particular emphasis on obtaining an acceleration curve which

would give the desired result without excessive strain on the film. While the acceleration must of necessity be very rapid the rate of range of acceleration has been carefully chosen to prevent any damage to the film under normal conditions. The deceleration of the film during the latter part of the pulldown cycle has also been designed with minimum stress on the film in mind. During the deceleration period, registration is established by using the trailing edge of the sprocket hole instead of the leading edge as is done in the usual type of projector. It has been found that this method of registration results in picture steadiness frequently better than that encountered in normal machines. The additional strain on the film because of the rapid pulldown means that special care must be exercised in making film splices. If a satisfactory splice has been made the machine will perform satisfactorily for hundreds of times without difficulty.

Non-Synchronous Operation of Projectors Used with Storage Pickup Tubes

An important factor which must be considered in connection with the problem of

televising color film is the necessity for controlling the sync generator output signal frequencies from a crystal oscillator which establishes the correct sub-carrier frequency. With this arrangement, it is no longer possible to operate with the sync generator locked to the 60 cycle power system as is normally done in monochrome television broadcast stations. Because of this it is necessary to use a power source for the projector driving motor which is automatically kept in synchronism with the vertical scanning frequency derived from the sync generator. The method used for accomplishing this synchronization is to use a 500 watt audio amplifier as a power source for the motor. A 60 cycle wave form

obtained from the synchronizing generator is used as the input voltage for the amplifier. An accurate phase relationship must also be maintained between the driving motor and the vertical blanking pulse applied to the flying spot tube so that the film motion always takes place during the vertical blanking interval. Because the time interval permitted for this motion is nearly equal to the standard vertical blanking period this phase angle must be maintained within rather close tolerances.

The Flying Spot Scanner

The color flying spot scanner associated with the projector is essentially the same as that used in the Color Slide Chain (see

Page 52). The only difference is the modification of the optical system and photocell assembly necessary because of the difference in optical requirements encountered with 16mm film. The dichroic mirrors and the filters have the same characteristics substantially as those used in the other application.

The particular advantage gained by using this method of color film scanning is that the three signals obtained from the three photocells corresponding to the three primary colors are automatically in register. For this reason, electrical operation of the equipment, its adjustment and maintenance is relatively simple.

FIG. 6. Closeup view of the 16mm fast pull-down projector equipment. A film control unit is located alongside the film equipment.

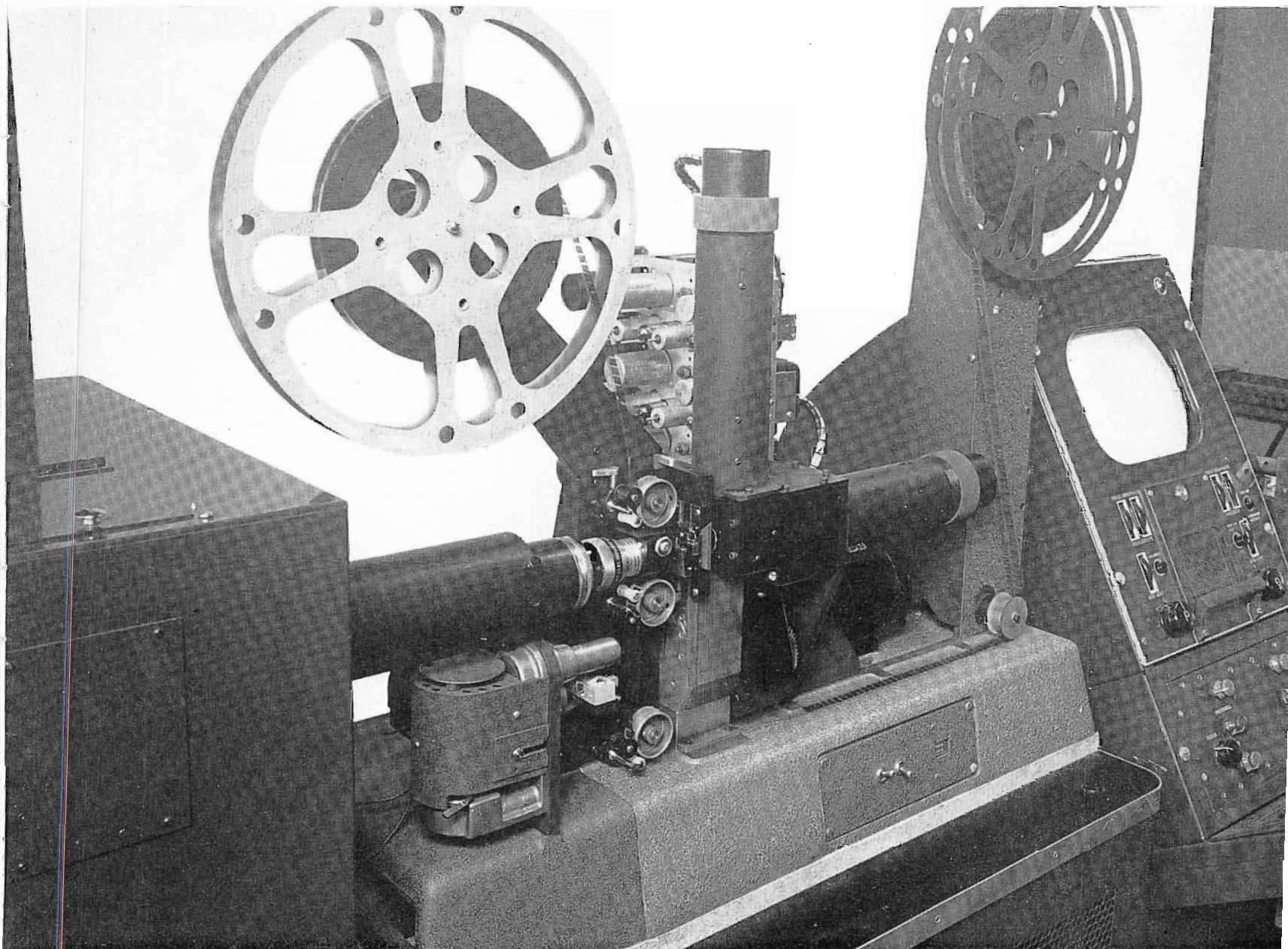



COLOR TELEVISION



RCA COLOR CAMERA, TK-40A

The development of the first color television camera equipment of commercial design was begun by the RCA Victor Division in the early part of 1950, as part of the color television activity of RCA. For several years prior to this time, basic development of simultaneous camera equipment for live pick-up of television programs in color was in progress at RCA Laboratories. Several developmental type

by **F. W. MILLSPAUGH**
Supervisor, Color Camera
Development Group

color camera chains were produced and successfully demonstrated in connection with this work early. The experience gained was utilized in designing the first "commercial-type" cameras.

A number of color camera chains of the experimental commercial design previously described elsewhere, were produced and made a part of the NBC experimental color television operations in their New York studios. Months of daily operational tests, incorporating a number of experimental programs, made it possible to rigorously test that equipment for all of the qualities required for good commercial op-

eration, already well established in Monochrome equipment. The need for improvements in a number of areas, particularly in the color camera, became evident during this period.

Described here is color camera chain equipment which will be part of the color television studio broadcasting equipment supplied by RCA to Broadcasters in the early part of 1954, for commercial color television broadcasting using FCC Color Signal Specifications.

Color Camera Chain Components

The color camera chain is similar in many respects to the Monochrome camera chains now in use in that it includes a live pick-up camera and several signal processing and control units. The block diagram of Fig. 2 shows a complete camera chain as it is related to the units to be described.

The color camera proper contains an image divider or light splitting optical system, three separate image orthicon tubes to provide red, blue and green signals, three video preamplifiers, horizontal and vertical deflection circuits for the image orthicons, and a high voltage supply derived from the horizontal deflection unit. The electronic viewfinder is comprised of a 7TP4 kinescope with necessary deflection and video circuits to provide a picture for the camera operator. The frequency response of the camera output signals is corrected in the aperture compensator. The camera control or color channel amplifier performs processing operations on the camera signals. These operations include the insertion of standard blanking pulses, shading correction and pedestal control. Operating controls and selected set-up controls are available on a remote control panel mounted in a standard console which is also used for shading operations. A modified Master Monitor and auxiliary switching unit are mounted in an adjacent console unit as shown in Fig. 3. This unit provides both kinescope and CRO displays of the processed color camera signals for the video operator.

Optical System

Viewed externally, the lens turret portion of the color camera optics is quite similar in appearance to the lens turret of the RCA Monochrome camera. However the similarity ends there. The light splitting optical system of the color camera comprises a number of special optical elements interposed in the image light path between the objective or taking lens and the photocathodes of the three image orth-

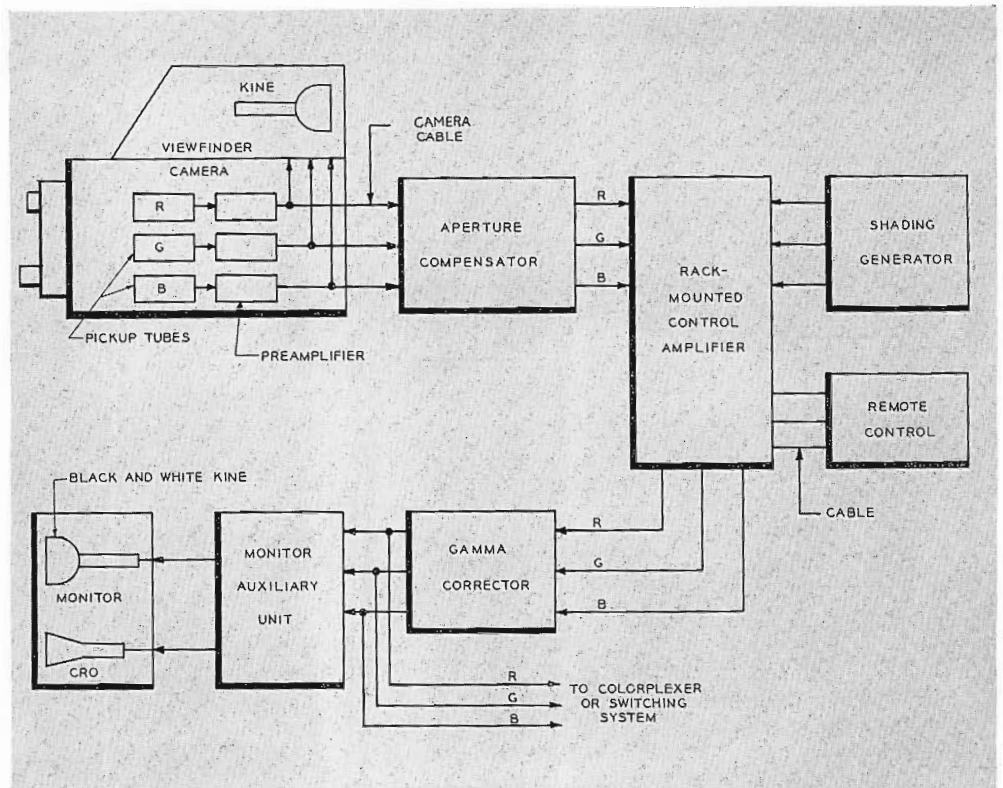
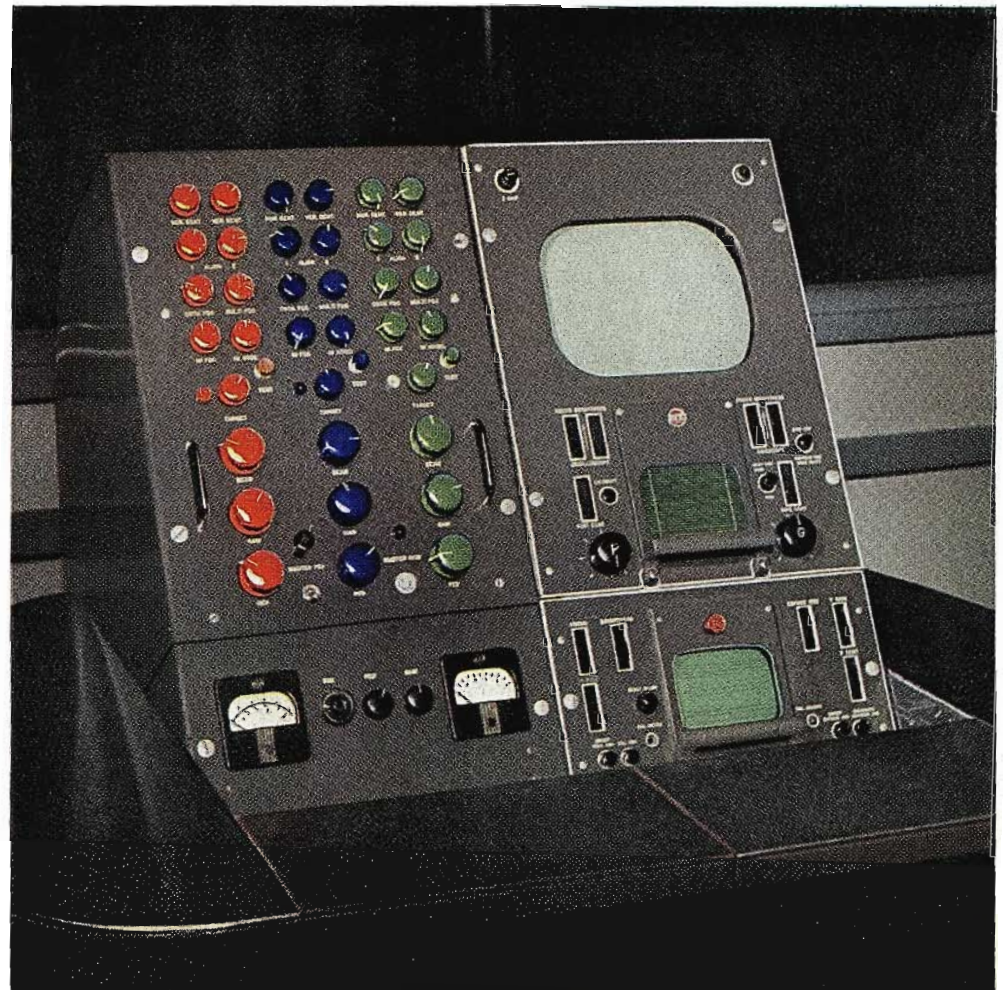

FIG. 2. Block diagram showing the arrangement of units in an RCA Color Camera Chain.

FIG. 3. Remote control panel and master monitor mounted in a console housing in development engineering studios at Camden. Note color-coded banks of controls for red, green and blue channels.



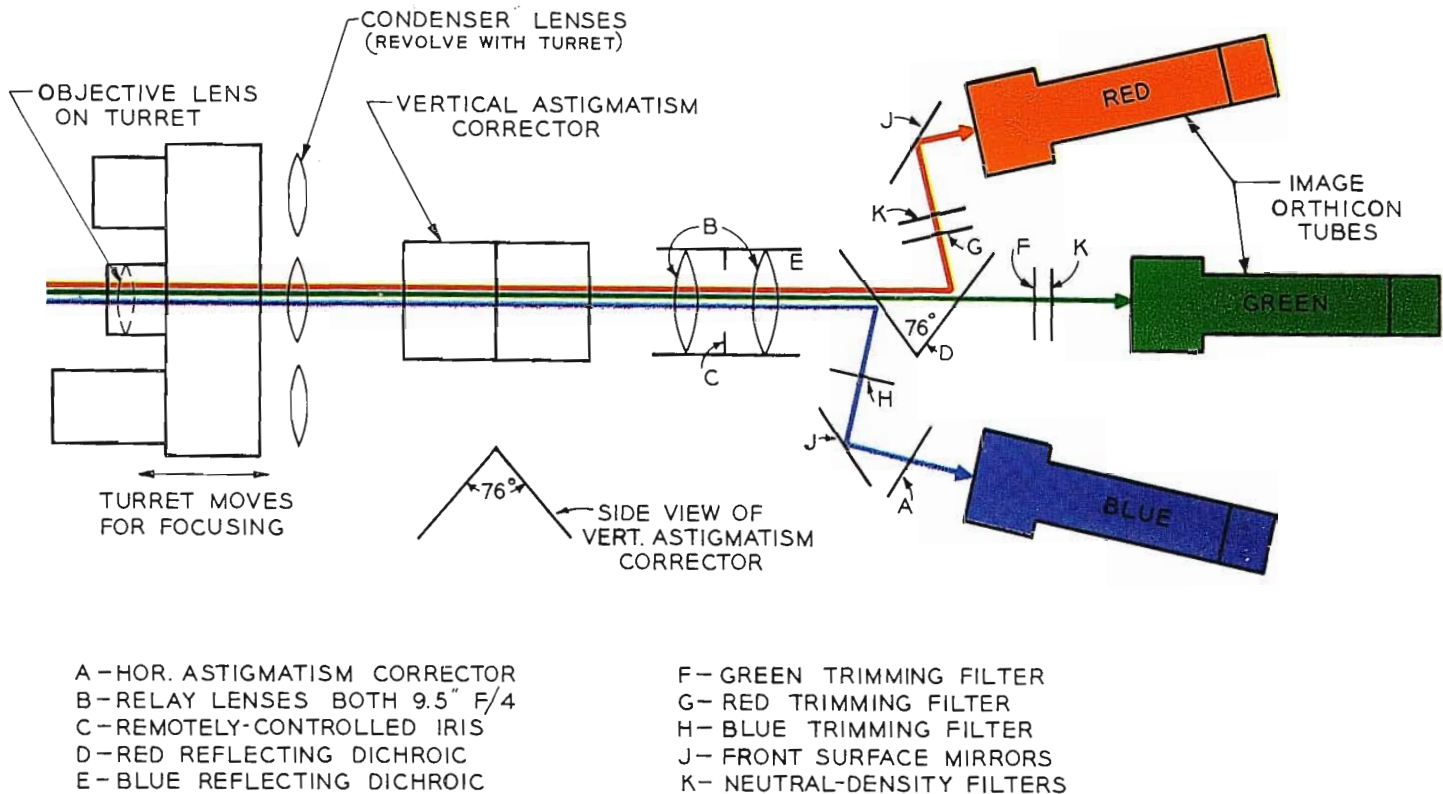

FIG. 4. Sketch of the optical system used in the RCA three-tube Color Camera showing the action of dichroic mirrors in separating the red, green, and blue components of the color spectrum.

icons. Location of these optical elements is indicated in the diagram of Fig. 4. The rotatable lens turret accommodates four objective lenses of different focal lengths. These lenses provide the program director with the same degree of programming flexibility which he is accustomed to having in Monochrome operations. The camera man is able to change lenses rapidly by rotating a turret positioning handle at the rear of the camera. Accurate positioning of the lens turret is insured by a positive detent mechanism.

Since the distance between the objective lens mount and the image plane of the lenses used is limited to approximately $1\frac{1}{8}$ inches, a fixed relay lens system is required in order to provide sufficient working space for the dichroic mirror light splitters. Field lenses designed for each of the objective lenses used are mounted on a spider located directly behind the lens turret support drum. This spider rotates with the lens turret as lens positions are changed. All the field lenses are designed with identical thickness and location to avoid changes in the position of the primary image as lenses are interchanged. The field lens functions to redirect all of the light reaching the image plane from the objective lens so that it will enter the relay lens system and insure uniform illumination of the relayed image. The size

of the primary image is not changed by the field lens. In general the field lenses must have a different power characteristic for each objective lens used. In some cases it has been found that the same field lens can be used satisfactorily with different objective lenses. The relay lens system transfers the real or primary image from its focal plane in the field lens to the photocathodes of the image orthicons.

Light reaching the dichroic mirror light splitter, following the relay lens, is divided into its red, green and blue components as predetermined by the spectral characteristics. Astigmatism is introduced in the light path by the dichroic-mirror assembly since the displacement of rays passing through the mirrors differ in the horizontal and vertical directions. To correct for this astigmatism, two optically ground plates are mounted ahead of the relay lens. These plates introduce a negative astigmatism, thus balancing the system. A single plate astigmatism corrector is also mounted in the blue channel so that the light rays in the red, green and blue channels will pass through the same total thickness of glass. All glass surfaces are coated to minimize reflections.

A remotely controlled iris located between the two relay lenses acts as the major overall gain control for the entire

camera chain. Dyed-gelatin Wratten type filters and glass filters are used in conjunction with the dichroic mirrors to adjust the overall spectral sensitivity curves as desired for the camera. Neutral density filters are inserted in the light path to adjust the relative sensitivity of the three image orthicons so that they all operate over the same portion of their transfer characteristics. Since it is only necessary to reduce the sensitivity of two of the channels to match the least sensitive, only two neutral-density filters are required. In studio use of the camera where the illumination is obtained from tungsten lamps, the blue channel is usually the least sensitive, because of the deficiency of blue energy in the light source. Therefore, neutral density filters are generally used in the red and green channels.

Color Camera

Fig. 5 shows an RCA color television camera, with viewfinder attached, mounted on a TD-1A RCA Studio Camera pedestal. A special swivel type friction head with 200-pound control spring and necessary locking devices provides the panning and tilting action required. The height of the camera proper is 15 inches—27 inches with viewfinder. The width tapers from 16 inches at the front to a maximum of 21 inches at the rear edges of the side door

covers. A hinged ventilation hood ahead of the viewfinder offers accessibility to parts of the optical system that lie beneath it in the camera proper.

Two blowers on the rear panel and one on the side panel near the rear of the camera are used to move cool air along each of the three image orthicons in their respective yoke assemblies. A similar blower is centrally located in the viewfinder to exhaust air from the body of the camera. These blowers plus ample louvres in the viewfinder hood comprise the ventilation system of the camera. All external areas of the camera and viewfinder which are subject to absorption of radiant heat energy, have an aluminum finish to further aid in maintaining optimum temperature conditions within the camera.

An adjustable panning handle is attached at the left rear corner of the camera base; at the right rear corner is attached a focus handle. The panning handle is used by the camera man to pan or tilt the camera, while rotation of the focus handle moves the lens turret longitudinally to adjust the focus of the objective lens.

Three standard RCA camera cables are plugged into receptacles mounted in such a manner as to permit the cables to be conveniently brought toward the front of the camera, drawn through a special cable clamping bracket, and then draped in a gradual curve to the floor. In this manner the cables can be effectively kept from interfering with the movements of the camera man. Camera tally lights are shown on the front panel beneath the lens turret.

In Fig. 6 a rear view of the color camera shows the viewing hood attached to the viewfinder. The eyepiece of the viewing hood is adjusted to accommodate variations in height of camera men and angles of tilt of the camera. The assembly may be removed easily by releasing a captive screw on either side. The lens turret rotation control handle, the lens position indexing plate and the intakes for two of the image orthicon blowers are also visible. The blower intake for the third channel appears on the small side panel near the rear of the camera. The panning handle at the left and the focusing handle on the right are in normal operating position.

The high degree of accessibility to all units and component parts in the RCA Color Camera for electrical or mechanical



FIG. 5. Side view of "all electronic" RCA Color Camera and Viewfinder.

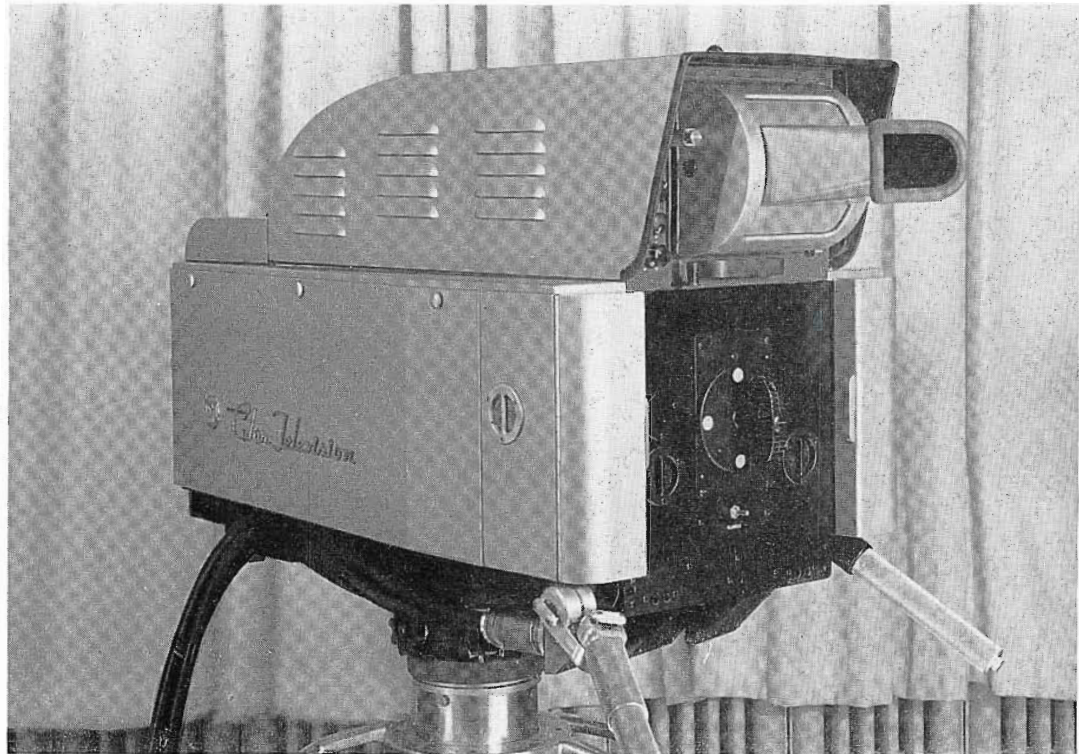

FIG. 6. Rear view of RCA Color Camera with viewing hood in place.

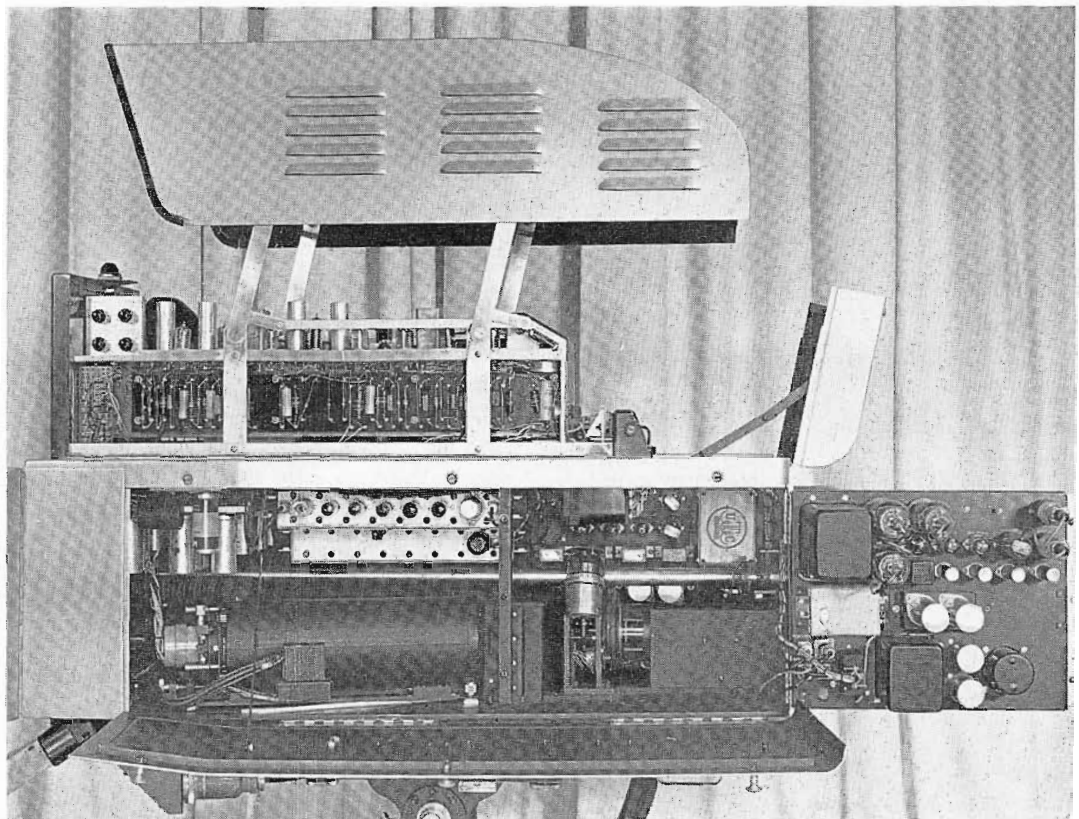

FIG. 7. View of RCA Color Camera showing extreme accessibility of components for ease of adjustment and repair.

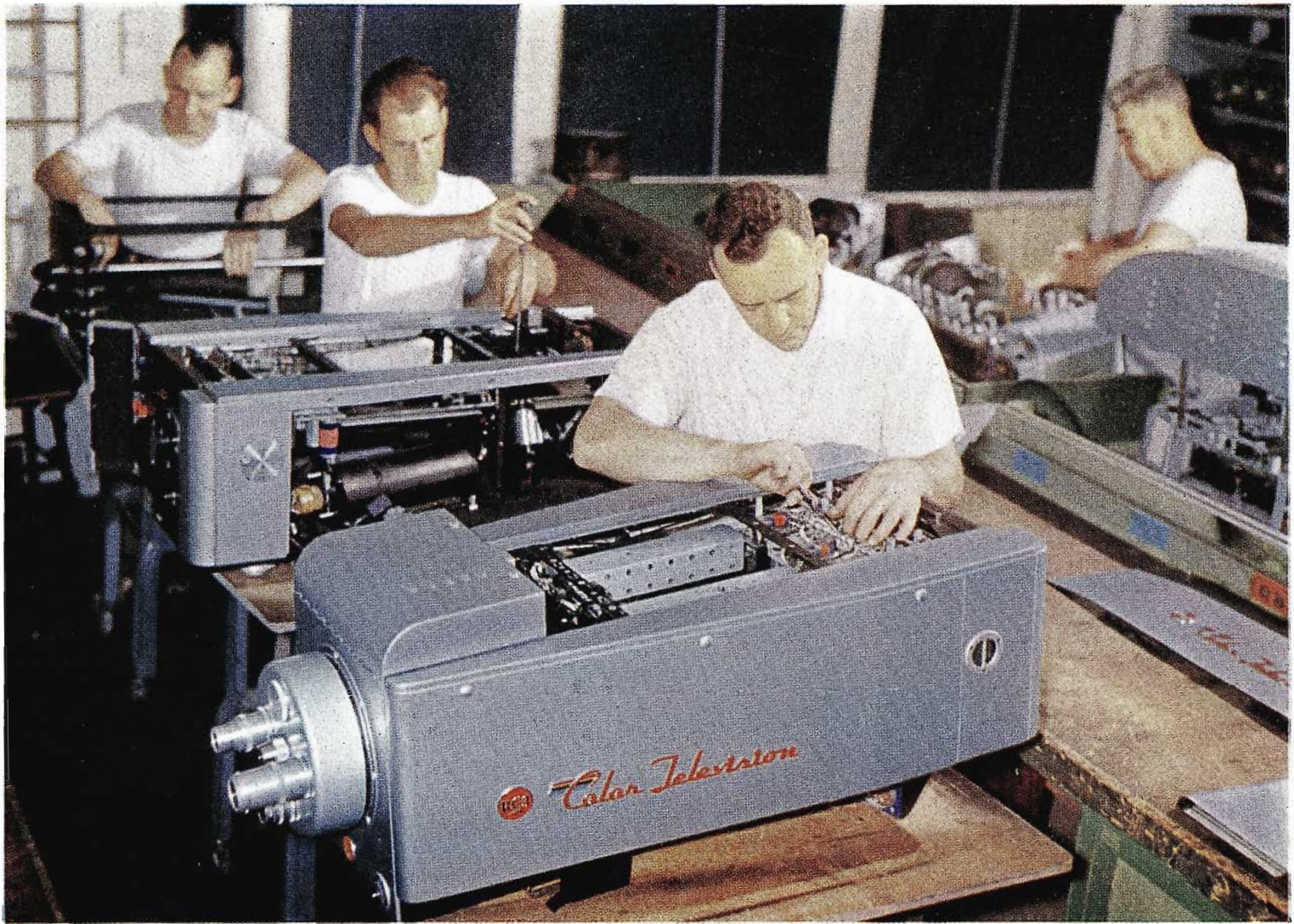

FIG. 8. Workmen assemble RCA Color Television Cameras. These cameras and other items of Color Television Broadcast Equipment have been made available to Broadcasters everywhere.

adjustments, or service testing or replacements, is emphasized by Fig. 7. The right side door of the camera is dropped in order to expose the yoke assembly of the red channel and the tube side of the red channel video preamplifier. The hinged horizontal deflection chassis is swung outward 180° from its normal position, permitting replacement of tubes, access to the remote iris synchro motor driving mechanism and other parts of the optical system or perhaps complete removal of the optical plate assembly, if necessary. The same degree of accessibility to video preamplifiers, deflection yoke assemblies and optical assembly is obtained by opening the left side door of the camera. Swinging the hinged vertical deflection chassis on the left side outward by 180° permits further access to elements of the optical plate assembly.

The type 1854 image orthicons can be replaced by removing a single holding screw on each yoke assembly and swinging the assembly out the side of the camera.

The center yoke is accessible once the left yoke has been swung outward. It can be released in the same manner and will swing outward over its set of yoke assembly rest plates.

Raising the ventilation hood at the front of the camera gives access to the connections of two heater transformers in this area as well as the relay lens and vertical compensator elements of the optical system. The elapsed time indicator showing hours of operation of the camera may also be read easily when the hood is raised. Viewfinder component and circuit tests together with tube replacements may be made with the viewfinder hood in the raised position. The viewfinder itself is removed by simultaneously releasing the locking catch on its control panel and sliding the viewfinder toward the rear of the camera. This provides access to wiring of the shelf type chassis at the rear of the camera as well as easy replacement of any of the camera preamplifiers.

Rotation of the lens turret and its longitudinal movement for adjusting optical focus is accomplished by the use of two concentric shafts and mechanical linkages which extend through the center of the camera. The outer (focusing) shaft does not rotate, but is moved horizontally through the mechanical linkage driven by the focusing handle. Rotation of the focus handle is transmitted to the focusing shaft through a set of beveled gears in the base of the handle to a toothed composition belt and pulley combination, and a gear box and lead screw which couples to, and actuates, the focusing shaft.

Details of the lens turret assembly are shown in Fig. 9. The lens turret rotates over a stationary drum turret support attached to the front plate of the camera frame. This drum acts as a light trap for the lens turret as it is moved in or out for focusing. On the lens turret is mounted a spindle which passes through a bearing in the turret support drum and is keyed to

the inner or lens turret rotating shaft inside of the focusing shaft. A spider which mounts the field lenses fits inside the turret support drum as shown at the left in Fig. 9. This assembly is driven from the turret spindle by a long stud and fork coupling, thereby permitting the field lens to be changed simultaneously with the objective lens. The outer or focusing shaft is attached to the turret spindle by a collar so that longitudinal focusing motion can be obtained by sliding the turret spindle in the slot of the indexed lens rotating shaft. One of the field lenses may be seen through the elliptical slot of the turret support drum as viewed from the front. Since each objective lens requires a particular field lens, provision is made for convenient change by the partial removal of two retaining screws and a half turn of rotation of the field lens holder.

Registration

While the attainment of good registration of three images required for color television may be considered the most difficult part of the color camera chain adjustment, experimental operations over a considerable period of time indicate that a high degree of skill can be developed as familiarity with the equipment and operating experience is gained. Electrical, mechanical and optical adjustments are made available to make good registration possible. The complexity of electrical registration adjustments is reduced in a large measure by connecting the deflection yokes in parallel and driving them from common deflection circuits. Electrical registration controls on the rear plate of the camera are shown in Fig. 10. They include the following independent controls: red and blue skew (with polarity reversing switch), height, width and the horizontal Q adjustment (see Page 16). A "vertical Q" controls bracket is mounted just inside the left side cover near the blower motor.

Thumb screw adjustments for yoke rotation and yoke assembly adjustment for focusing are available for convenient adjustment of the red and blue yoke assemblies. Adjustments for the green yoke assembly can be made with a screwdriver from the rear control panel of the camera. Adjustment of the individual size control is accomplished by the variation of small impedances in series with the respective deflection yokes. In the case of the indi-

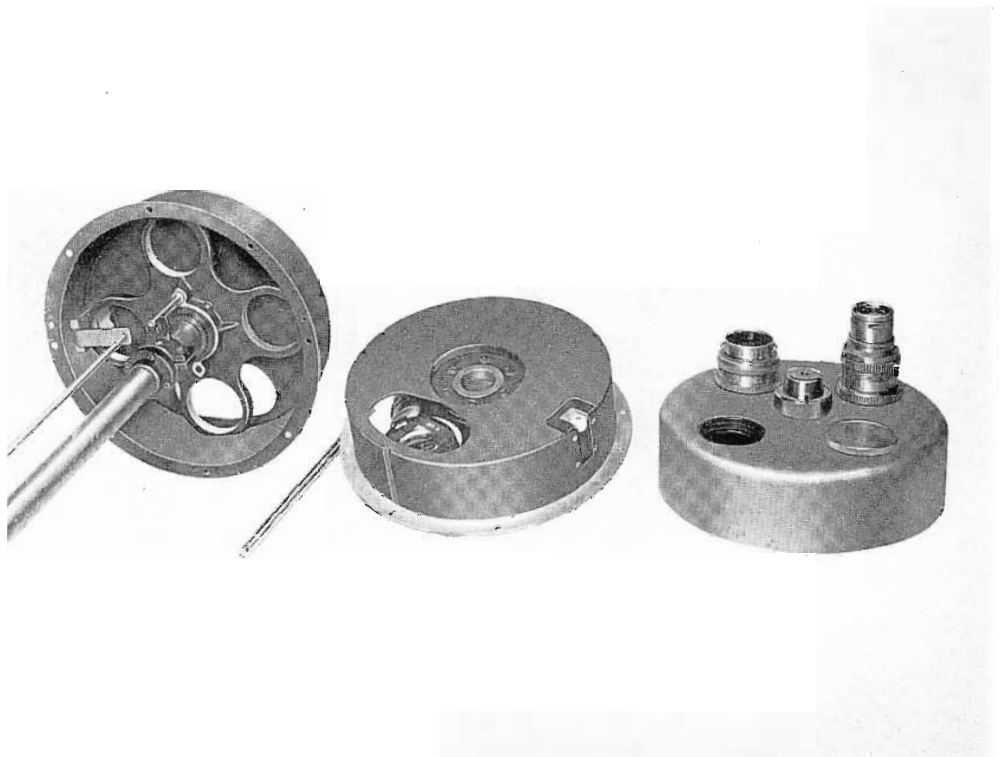

FIG. 9. Details of the lens turret assembly showing the rotating turret drum, the stationary turret drum and the lens turret assemblies.

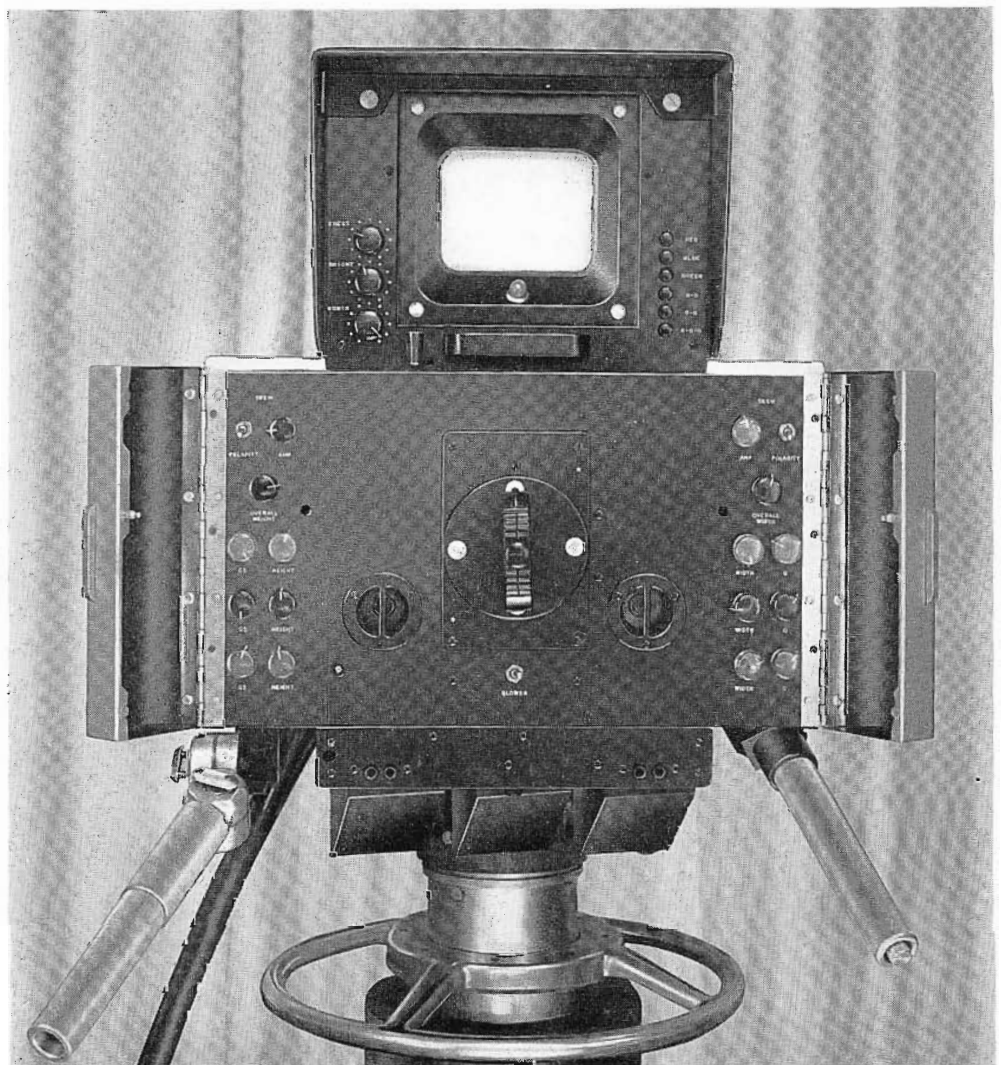

FIG. 10. Rear view of camera showing the location of registration controls.

vidual horizontal deflection circuit, the width is controlled by variable inductances. Therefore, to maintain constant linearity of deflection as the width control is varied, it is necessary to adjust the resistance component of the circuit by means of the variable resistance horizontal Q control. Since the vertical yoke impedance is largely resistive at the 60 cycle field frequency, individual height adjustments are obtained by variable resistors. As in the case of the width control, adjustment of the variable resistor height control likewise requires readjustment of the Q of the individual deflection circuit by variation of the vertical Q control reactance.

The skew control is an unconventional control which has been found essential in obtaining good registration of the three color images. Because of the tendency of some deflection yokes to produce slightly rhombic rasters under optimum conditions of adjustment, it is necessary for best registration to match two yokes with the third by means of the skew control. This correction is obtained by introducing a very small amount of vertical deflection sawtooth deflection current in series with the individual horizontal deflection circuits. A "T pad" adjusts the amplitude applied and a polarity reversing switch selects the polarity required.

During program operations in the studio, the electrical controls at the rear of the camera are enclosed by hinged covers. The camera operator is only required to move the camera as directed (via headphones connected to the intercom panel directly below the rear panel of the camera), select the proper lens and keep the picture in optical focus by observing the viewfinder image.

Located on the left side of the viewfinder control panel are focus, brightness and contrast adjustments for the viewfinder kinescope. On the right side of this control panel, a series of six push buttons, mounted vertically in a row, permit the camera operator to observe a black and white image of any single channel, combinations of the red and green or blue and green channels or all three channels combined. The latter combination is used by the camera operator working with the video control operator in making final registration adjustments.

The turret rotating handle with indexing tabs, the intercom panel for headsets of the camera and dolly operators, off-on switch for blower motors, two of the air intakes for the blowers and the body of the camera are also shown in Fig. 9.

Three rack mounted signal processing units—the aperture compensator, color channel amplifier and the gamma corrector—follow the color camera in the sequence named.

Color Camera Aperture Compensator

The function of the aperture compensator is to compensate for the loss in the high frequency response of the video signal generated in the color camera and thereby avoid impairment in the fine detail of the image to be reproduced. The loss of high frequency response is inherent in all television pick-up devices because of the finite size of the scanning aperture and the limit of resolution capabilities imposed by the particular optical system being used.

The effective frequency response curve in the lower left of Fig. 11 graphically indicates the extent of this loss in a typical image orthicon-lens combination. A simplified block diagram of one channel of the aperture compensator is shown in the upper part of Fig. 11. A typical frequency response curve for one channel of the aperture compensator is shown at the lower right of Fig. 11.

Several sections of a lumped-constant delay line (designed to have an electrical length of one half wave length [180°] at 10 mc) provide high frequency amplitude boost with linear phase shift vs. frequency over the entire video band. The sending end of the delay line is terminated in its characteristic impedance, while the receiving end is open circuited. The voltages at each end of the delay line are the same in phase but different in amplitude, since the voltages at the open circuited end remain substantially constant with

change of frequency. The terminated end varies with frequency because of the effect of the reflected signal from the open circuited end of the line. The signals appearing at each end of the line are subtracted in a differential amplifier to obtain a difference signal, which follows a $1-\cos \theta$ response (θ being the electrical length of the line in terms of frequency). Two potentiometers, mechanically connected in tandem, operate as variable plate loads of the differential amplifier and provide the frequency boost control. This control is capable of adjusting the boost over a wide range of frequencies. A maximum boost of about 10:1 is available with the peak occurring at 10 mc.

The aperture compensator unit requires four tubes per channel. The signal input from the camera video preamplifiers is received at 0.3 volt peak to peak level in the first or gain control stage. The output stage is a two tube feedback amplifier designed to provide sending and termination of a 51 ohm line. Each channel is normally adjusted to overall gain of unity. A switch is also available to permit each channel to be cut in or out of the camera chain for convenience in making this adjustment. Pin jack test points for input and output signals are provided for each channel.

Functions of the Aperture Compensator as applied to the Color Slide Camera are discussed in W. E. Tucker's "Color Slide Camera," Page 56. The Aperture Compensator is pictured in this article.

Color Channel Amplifier

The color channel amplifier of the color camera chain is functionally the equiv-

FIG. 11. Block diagram of the constant delay line aperture compensator.

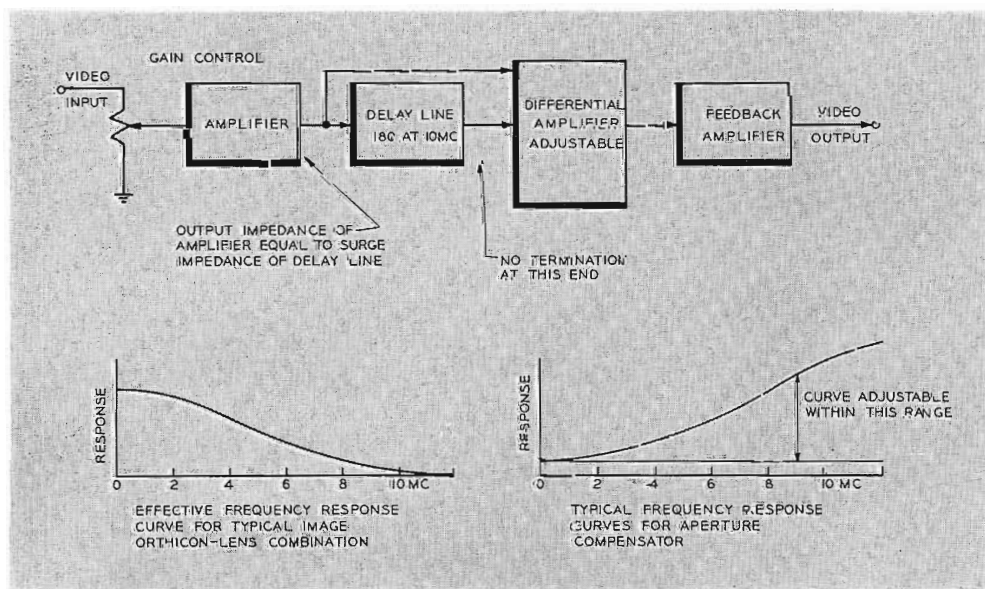

alent of a camera control amplifier unit of the Monochrome camera chain. As indicated in the block diagram of Fig. 12, it contains three identical channels designed to receive the red, blue and green video signal from the aperture compensator, (or the color camera preamplifiers when the aperture compensator is by-passed), process and amplify them from a 0.3 volt peak to peak signal across 51 ohm input impedance (camera cable impedance) to 1.0 volt peak to peak output in 75 ohms terminating impedance.

Additional amplifiers referred to as the common channel in the block diagram, provide common horizontal driving and blanking signals to each color channel. Horizontal and vertical driving signals for the deflection circuits of the color camera terminated in 51 ohms, are also provided by these amplifiers. An input connection is available for a step wedge signal used for testing the amplitude linearity and setting the gain of each channel to the same level. Provision is made for clipping noise from the reference black level of the video signals received from the color camera and the addition of blanking in an amount determined by the setting of the pedestal control on the remote control panel. Signals from the shading generator, also located at the remote control position, are mixed with the video signals in each channel to correct for shading in the image orthicons.

The functions performed by one color channel are indicated in the block diagram of Fig. 12.

A similar channel amplifier is utilized in the operation of the RCA Color Slide Camer. This amplifier is discussed in detail in W. E. Tucker's "Color Slide Camera," Page 56.

Circuits and Operation

The first video amplifier has a bias control in the cathode circuit to set the line output level to 1.0 volt peak to peak when 0.3 volt is applied at the input. By monitoring the output and keeping this level at or below 1.0 volt peak-to-peak, the output of the camera preamplifier is maintained at or below 0.3 volt peak to peak. If the output of the preamplifier is greater than 0.3 volt peak to peak, compression of the signal occurs in the preamplifier and the input to the preamplifier must be reduced. The input level of the preamplifier is controlled by the dynode gain control of the image orthicon. (This control is located on the camera remote control panel which is illustrated in Fig. 3, Page 63.)

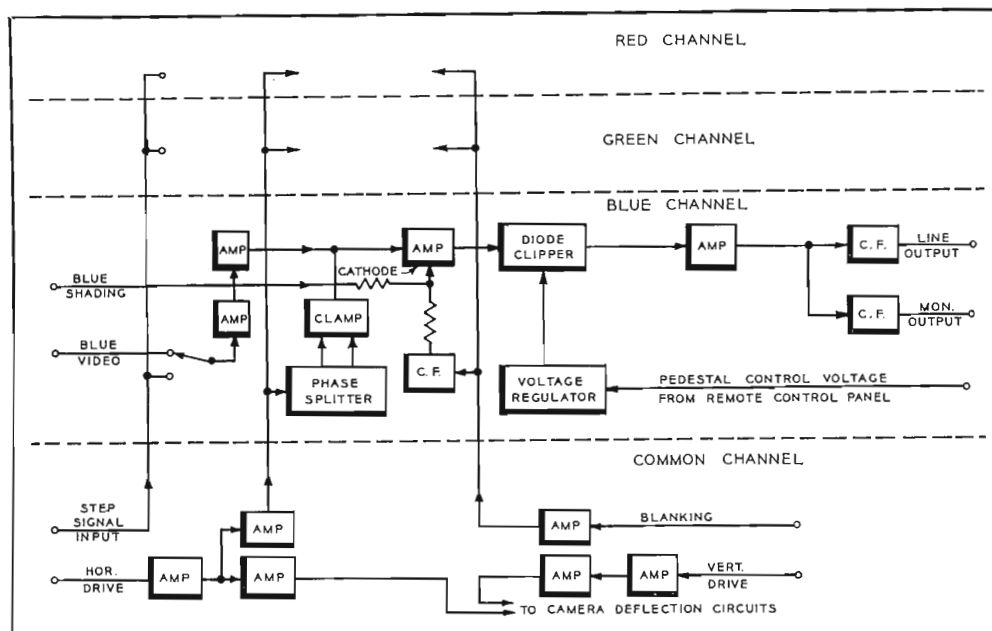

FIG. 12. Block diagram showing the functions of a Color Television camera control amplifier.

The second video amplifier contains a cable length switch to change the by-pass capacity across the cathode resistance an amount necessary to compensate for losses of high frequencies in the camera cable. Such losses are a function of cable length.

The signal is then clamped to ground potential during camera blanking. This is to present a fixed reference point to the linear clipper. The balanced clamper is operated from clamp pulses derived from the phase splitter fed with horizontal drive pulses that have been amplified in the pulse amplifier.

The video amplifier following the clamper has mixed in its cathode circuit both blanking and shading signals. The blanking is fed to the grid of the blanking mixer tube which has a common cathode resistor with this video amplifier. The shading signal from the shading generator is isolated with a 3300 ohm resistor and also applied at this same cathode. The addition of blanking at this point serves to push the camera blanking (containing noise) down below black level so that it may be clipped to the desired level.

The plate of this video amplifier is directly connected to a linear clipper and transient suppressor. The linear clipper clips the camera blanking noise from the signal at a point determined by the potential on the plate. This potential is taken from the cathode of the pedestal control tube. This potential is also applied to the screen of the video amplifier ahead of

the linear clipper to serve as a low impedance series regulator voltage source and provide isolation from the B+ supply. The cathode potential of the transient suppressor is set with the transient suppressor potentiometer in a voltage divider network to a positive value just low enough to bypass to ground any positive spikes introduced by the linear clipper.

The output of the linear clipper is capacitively coupled to the grids of the two

FIG. 13. Channel amplifier chassis.

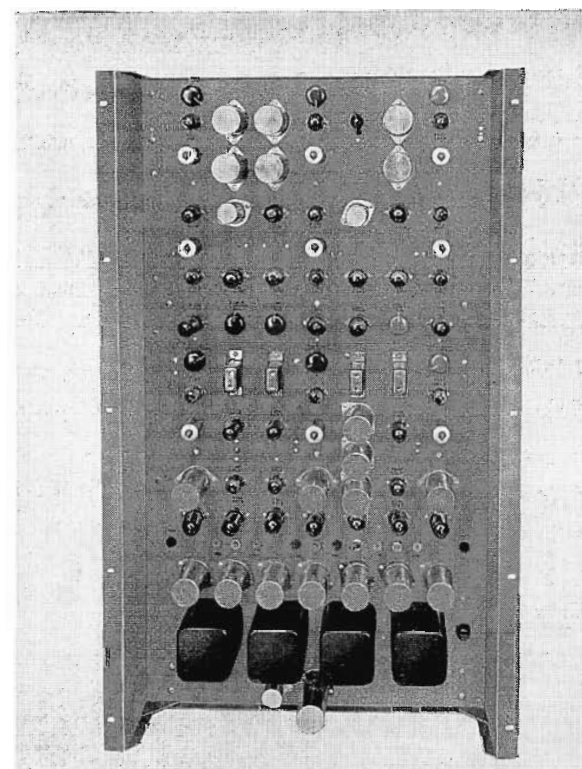

output tubes. A d-c restorer is connected to these grids for operation of the tube over the linear portion of its transfer characteristic. The line output is used as the reference for setting the level, and a bias control potentiometer is inserted in the cathode of the monitor output tube to balance the two outputs.

All signal and power cables of the color camera and equipment at the remote video control position are connected to their associated rack mounted equipment through a single terminal chassis usually mounted below the channel amplifier. Fig. 13 shows the physical appearance of the channel amplifier.

Color Camera Gamma Corrector

An important requirement for good fidelity in a color television system is that the overall transfer characteristic from the light input at the pick-up device to the light output of the reproducing device shall be linear. This means that in the case of the color camera chain, the light output at the color kinescope screen will vary in direct proportion to the input at the photocathode of the image orthicon pick-up tube. In other words, the exponent of the overall transfer gradient, or gamma, shall be unity in order for the equipment to meet the requirements of FCC signal specifications. In these specifications, the kinescope transfer gradient is specified as 2.2. Since the gamma of the image orthicon transfer characteristic has been found to be approximately .7, some compensation toward an overall gamma of unity is required. This additional compensation required to obtain unity gamma is accomplished by the gamma corrector.

As shown in the block diagram of one channel of the gamma corrector, Fig. 14, an amplifier stage precedes and follows the single non-linear gamma correction stage to maintain a suitable signal level to drive the feedback pair in the output stage, which in turn supplies the gamma corrected signal to the Colorplexer and control monitor at the video operator's control position. To accommodate the requirement of all non-linear operations, a driven clamp is used to restore the d-c component before the gamma correction is applied to the signal.

Gamma correction in the Color Camera Chain is somewhat different from that encountered in the operation of the Color Slide Camera. Gamma correction in the camera is explained in W. E. Tucker's "Color Slide Camera," Page 56.

A simplified schematic of the non-linear amplifier is also shown in Fig. 14. The

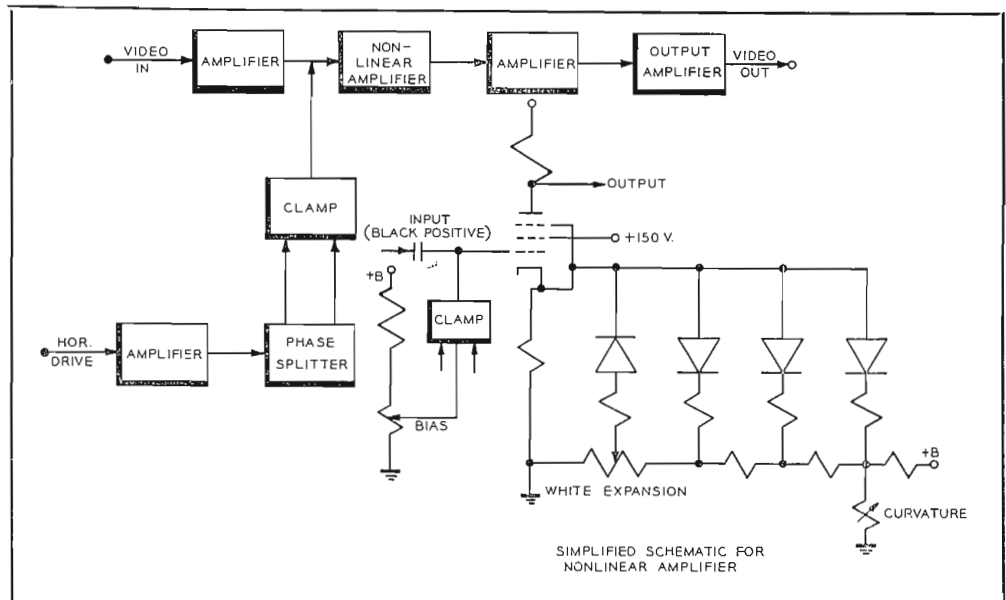

FIG. 14. Block diagram of one channel of a gamma corrector for a color camera.

necessary curvature of the transfer characteristic required to supplement the transfer characteristic of the image orthicon, and to produce an overall gamma of unity, is obtained by means of a non-linear, diode controlled, feedback circuit which is shunted across a cathode resistor in a conventional amplifier stage. As indicated in the schematic, the diodes are biased through series resistors so as to conduct at various voltage levels, thereby varying the feedback gain over the signal range from zero or black level to peak white level. An arrangement of diodes, with individual bias adjustments for each, permits greater ease of adjustment and provides

adjustments to stretch the black and to compress the white regions of the transfer curve. The polarity of the signal input to the non-linear amplifier is such that black is in the positive direction. Controls are indicated for adjustment to the desired curvature in both the black and white regions.

Shading Generator

The shading signals introduced into each channel of the channel amplifier are needed to correct for the non-uniformity in signal sensitivity over the area scanned in each of the three image orthicons. The shading generator unit shown in Fig. 15 is mounted

FIG. 15. Shading generator assembly with control panel.

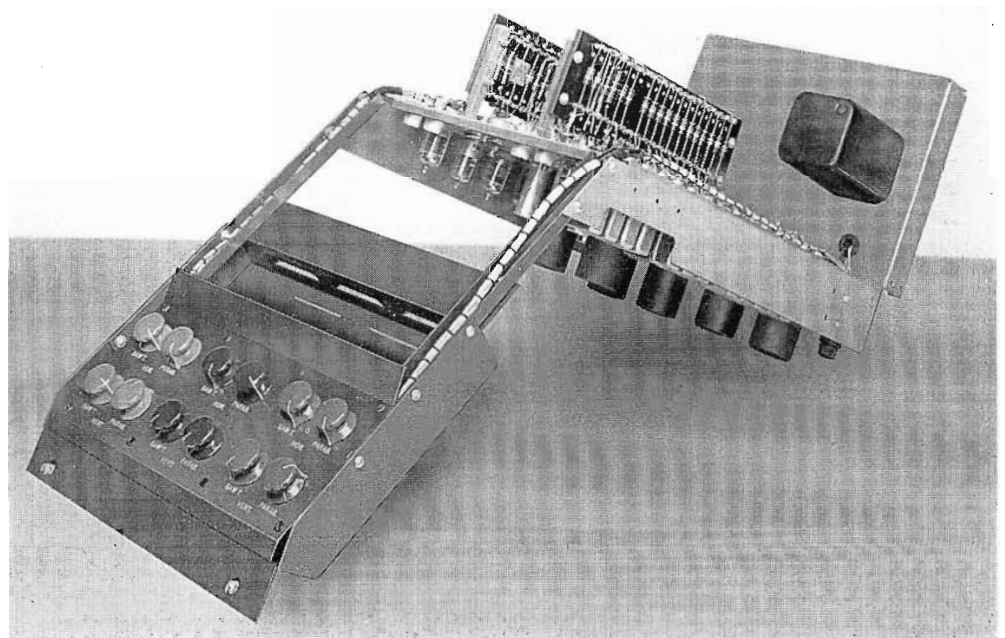

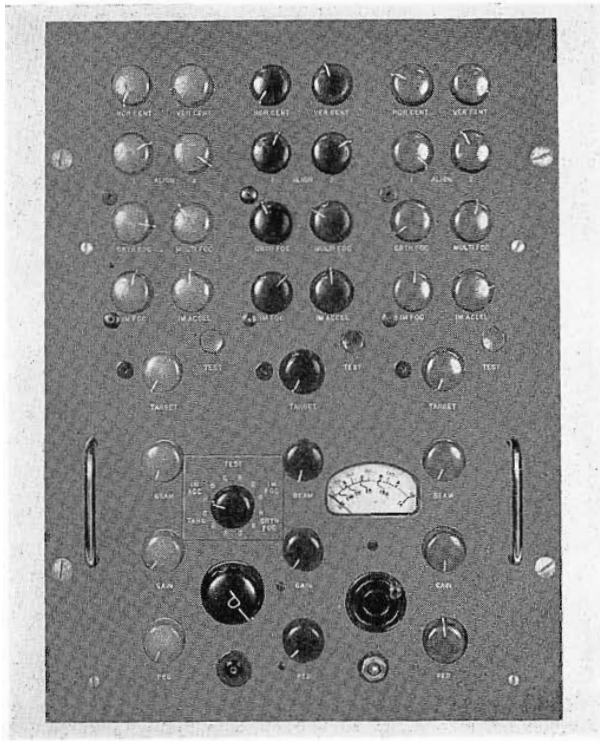

FIG. 16. Remote Control Panel mounts in a console housing next to the modified TM-6B Master Monitor.

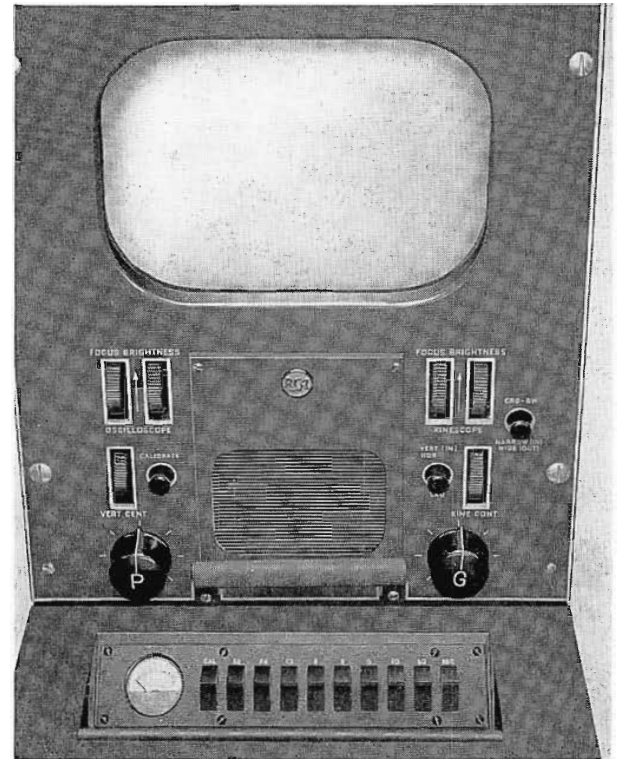

FIG. 17. The Modified TM-6B Master Monitor. An auxiliary switching unit is mounted in the panel below monitor.

in the lower section of a standard console section at the video control operator's position. Horizontal and vertical shading signals of sawtooth and parabola shape are available for each color channel. These controls are mounted on the sloping portion of the console shelf and are identified with the respective channels by knobs of the same color. The sawtooth signal is generated in the conventional manner and the parabolic signal is obtained by shaping the sawtooth wave in an integrating circuit. While the undesirable shading effects which originate in the image orthicon are kept to a minimum in its manufacture, the adverse effects on color balance due to the presence of shading in the video signal, requires that careful attention be given to correction by adjustment of the shading generator. Normally the adjustments are required only at the time of the overall set-up of the color camera chain or when an image orthicon is replaced.

Video Operator's Control Console

The video operator's control position for a single color camera chain is comprised of control and monitoring equipment housed in two standard RCA console sections. The camera control panel on which the remote control adjustments of the color camera are mounted is located in the upper part of the left hand console section while the shading generator unit is located in the lower portion. A Monochrome control monitor is located in the upper part of the

right hand console section. A monitor auxiliary unit is mounted directly beneath it.

Fig. 16 shows the remote control panel comprised of a group of symmetrically arranged operating controls for each of the three image orthicons. Colored knobs identify the controls with their respective channels. The individual channel controls include horizontal and vertical centering alignment (image orthicon beam), orthicon focus, image focus, multiplier focus, image accelerator voltage, target voltage, beam current, multiplier gain and pedestal. Button type switches adjacent to the target control knob provide a convenient means of adjusting the target two volts above cut off. A selector switch and pin jacks permit the metering of the target, orth focus, image focus and multiplier focus voltage settings in each color channel.

Also included on the camera control panel is a synchro control for operating the remote iris located between the two relay lenses in the camera optical system. Mounted directly above this control is the iris *f* stop indicator meter. In normal operation, the remote iris control performs the function of overall gain control for the complete color camera chain. A master pedestal control provides simultaneous adjustment of the pedestal voltage in the three channels.

The color control monitor is a modified Master Monitor with minor modifications necessary to permit its CRO to display in sequence, side by side, the scanned lines or

fields of the red, blue and green channels. This is accomplished by adjusting the sweep rate of the CRO to 20 and 5250 CPS for the field and line frequencies respectively, instead of the 30 and 7875 CPS rates originally used in this unit. For color control monitor use, the modified Master Monitor deflection circuits are driven directly by horizontal and vertical driving pulses as compared with similar triggering signals derived from a composite sync signal in Monochrome practice. The color control monitor and control panel of auxiliary unit are shown in Fig. 17.

The monitor auxiliary switching unit located below the control monitor in the console is comprised of a number of electronic video switching circuits which provide either field sequential or line sequential display of the three color signals on the CRO of the color control monitor. Also provided are switching facilities which permit the video control operator to select for viewing on the kinescope of the control monitor red, blue or green images separately, the red or blue superimposed on green or all three images superimposed. These signals may be monitored in the camera chain before and after the gamma correction circuits. The output signal of the Colorplexer may also be monitored. The push button switches which permit this selection of signals appear below the color monitor in Fig. 17. By means of an adaptor plate, this unit mounts in the sloping section of the console.

RCA COLOR TV MONITOR, TM-10A

By A. H. LIND

Manager, Audio, Projectors and Systems
Engineering Group

One of the units of Color Television equipment which holds high interest for engineers and laymen alike is the Color Television Monitor. The RCA TM-10A Color Television Monitor is designed around the RCA 15-inch Tricolor Kinescope. It is capable of reproducing the color picture from a composite Color Television signal.

The monitor is basically a chassis and front panel unit which can be housed in a cabinet, as illustrated in Fig. 1, mounted in a standard 19-inch cabinet rack by use of rack mounting hardware which is also available, or mounted in a housing of the customer's choice. To facilitate grouping when housed in cabinets, the cabinets have flat tops and are unobstructed on the top and sides. This permits placing monitors immediately adjacent to each other and/or

stacking vertically as conditions require. Forced ventilation is accomplished by means of an exhaust fan near the top on the back of the cabinet and an intake vent at the bottom of the cabinet back. This vent also serves to provide ready access to the signal and power input connectors as well as several set-up controls. On the front panel there are eight operating controls positioned between the kinescope and a hinged cover panel which is located near the bottom. With the cover panel open the set-up controls located on the front of the chassis are accessible. Thus direct viewing of the kinescope is possible while making these set-up adjustments.

Tricolor Kinescope

The tricolor kinescope is a directly-viewed, glass envelope, three gun, shadow mask type shown in Fig. 3. This tricolor

tube incorporates important differences from conventional monochrome kinescopes. First, instead of a uniformly coated phosphor screen, the color tube screen is composed of a regular pattern of small, closely spaced phosphor dots. These dots are arranged in triangular groups deposited very precisely on a glass plate support (see Fig. 4). Each group (or trio) consists of a red-emitting dot, a green-emitting dot and a blue-emitting dot. The phosphor screen contains 195,000 dot trios or 585,000 dots. The viewing screen provides a picture size of $11\frac{1}{2}$ inches by $8\frac{3}{8}$ inches high with rounded ends. Next, in the color tube there is a shadow mask. It is positioned parallel to and immediately behind (gun side) the phosphor screen as shown in Fig. 4. The mask contains the same number of small apertures as there are color dot trios on the phosphor plate. They are about the size of one phosphor dot and are located on the axis of their corresponding trio. By arranging the tube's geometry properly, an electron beam approaching the shadow mask at a slight angle from the line to the center of deflection, will land only on a single color in any one of three rotational positions 120 degrees apart. In order to obtain precise alignment between the apertures in the mask and the phosphor dots, the mask and phosphor dot plate are mounted together in an assembly. The mask functions to provide color separation by shadowing two of the three arrays of phosphor dots from each of the electron beams, while exposing the proper array to excitation by each beam.

Third, the color tube contains three electron guns. These parallel, closely spaced guns provide independent electron beams for excitation of each of the three phosphor dot arrays. The guns are controlled by the appropriate red, green and blue video signals supplied by the output stages of the color video channel.

In operation the three beams are deflected by a common scanning field and must be made to converge at the aperture corresponding to the dot trio being scanned at the moment. This convergence of the beams is accomplished by an electrostatic

FIG. 1. Cabinet mounted RCA TM-10A Color Television Monitor. The monitor may also be mounted in standard 19" cabinet racks or another housing of the customer's choice.

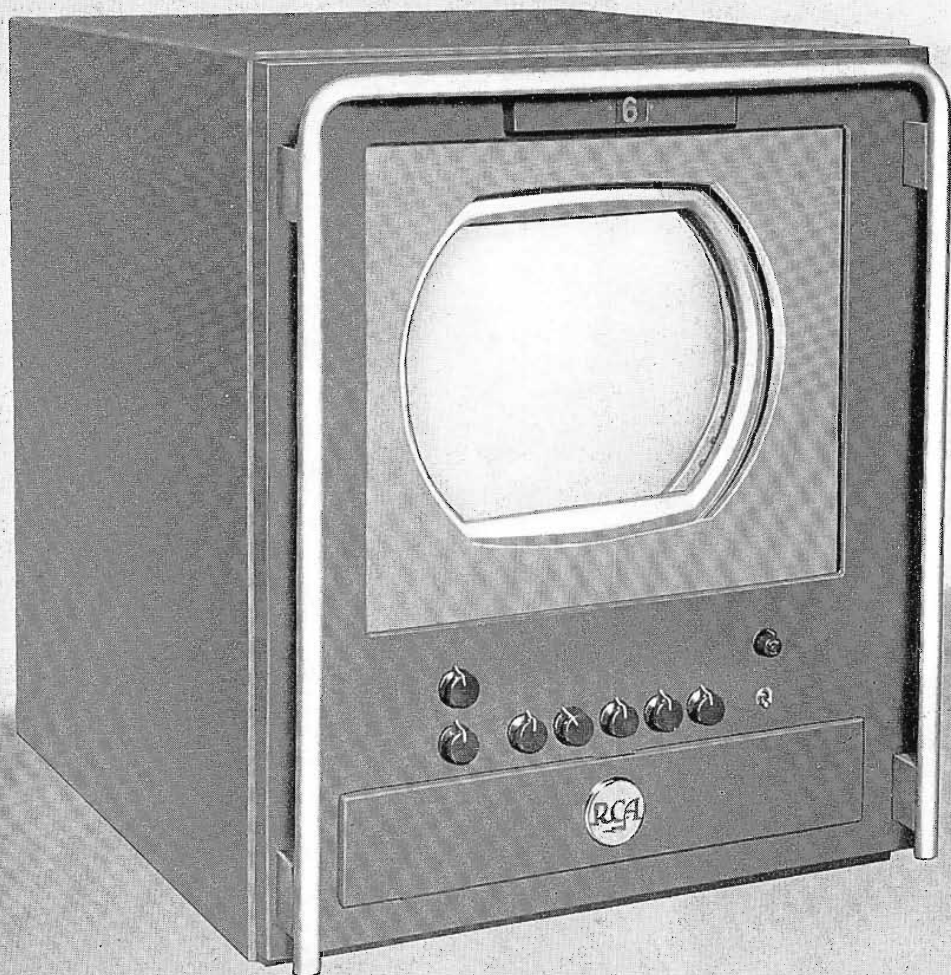



FIG. 2. Unretouched picture made directly from the face of an RCA Color Monitor. In making the plates for this illustration every care was exercised to obtain a reproduction which would give a true impression of the monitor picture. Model is Marie McNamara (Miss Color TV) as seen by RCA Color Studio Camera in NBC's Colonial Theatre Studio.

lens system that causes the beams to bend away from their individual gun axes toward the common axis of the gun array. To aid in the uniformity of convergence, the Purity Yoke (Fig. 4), when properly energized, positions the three beams symmetrically with respect to the common kinescope axis as the beams leave their respective guns. A given combination of potentials will cause the beams to converge at the mask apertures in the center of the phosphor plate area. However, because the shadow mask and phosphor plate are flat, the distance from the center of deflection to the mask apertures varies as a function of deflection which makes it necessary that the focal length of the converging lens be made to vary as a function of the deflecting angle. Thus the potentials required to

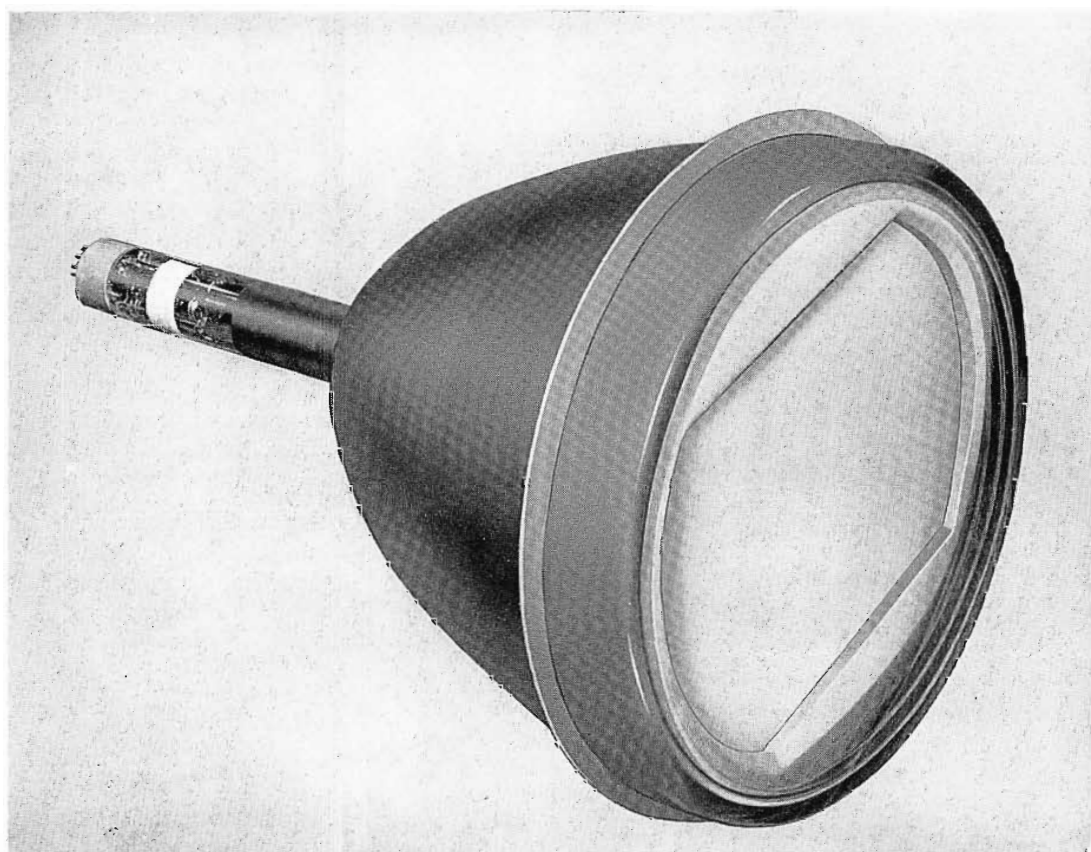

FIG. 3. RCA 15" Tricolor Kinescope around which the monitor is designed.

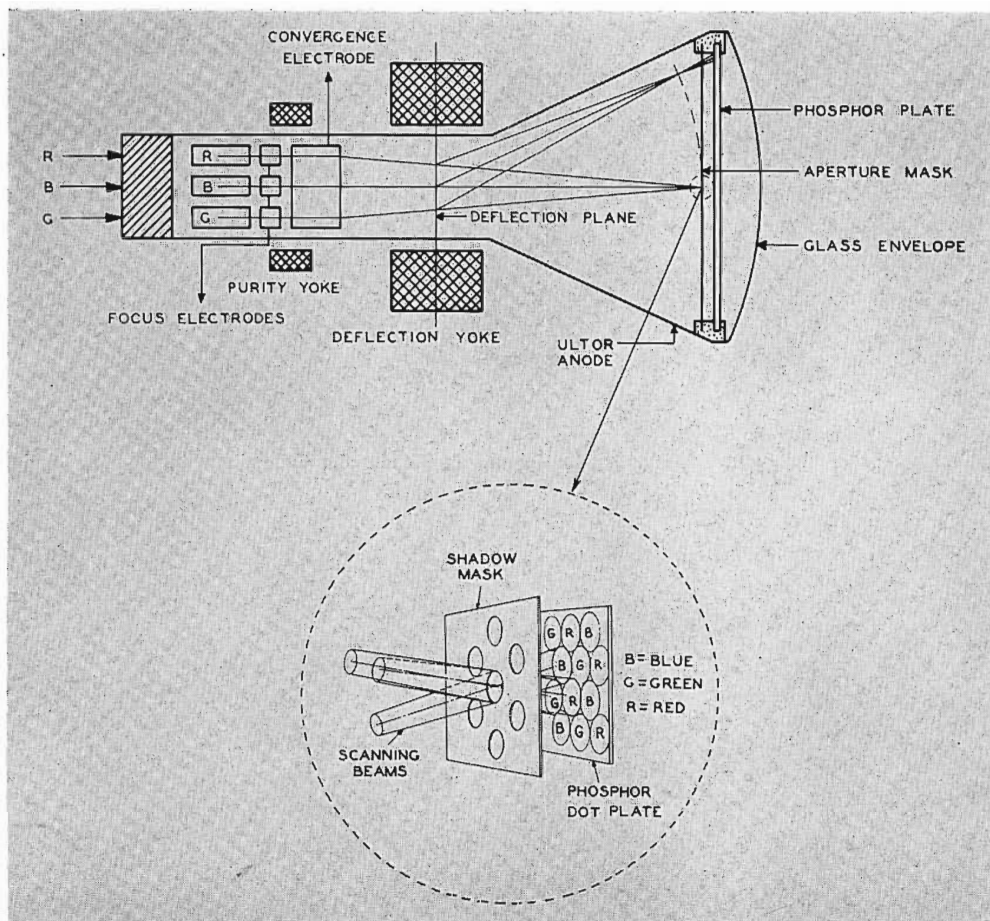

FIG. 4. Cross-sectional diagram of the tricolor Kinescope showing an enlarged section of the shadow mask and phosphor dot screen.

maintain proper convergence vary as a function of the deflecting angle. This dynamic converging is accomplished by applying voltage derived from the vertical and horizontal deflection circuits to result in a varying potential applied to the converging electrode.

The three beams are electrostatically focused. As in the case of converging the beams, the beam path length from the center of deflection to the shadow mask is a function of the area being scanned. Thus the focus potential must also be varied as a function of scanning. A voltage similar to that obtained for dynamic convergence is applied to the focus electrode to accomplish the dynamic focusing.

When properly focused and converged the beam from one gun sees only dots of one color no matter which part of the phosphor plate is being scanned. Thus, three primary color signals controlling the three beams produce independent pictures in the primary colors. To the eye these pictures blend because of the close spacing of the dots, and as a result the eye sees a full-color picture.

Circuit Description

A simplified block diagram is shown in

Fig. 5. To aid in understanding the circuits the blocks are grouped into five sections: Kinescope, Video Section, Color Sync Section, Deflection and High Voltage Section and Low Voltage Power Supply Section. Since the tricolor kinescope has been discussed, no further details on this section of the block diagram will be mentioned.

Video Section

After passing through a wideband video amplifier the signal is fed into two channels. One is the luminance or brightness (monochrome or M) channel and the other is the chrominance (color) channel. The circuit functions accomplished in the chrominance channel result in two signals I and Q being recovered. The I, Q and M signals are combined in a resistance mixing matrix circuit to produce R, G and B signals. (See Page 19, J. W. Wentworth's "RCA Color Television System.") These signals are then further amplified in the video output amplifiers and supplied to the appropriate tricolor kinescope control grids.

The monochrome channel includes a low pass filter, a delay line, an aperture compensator, and video amplifier stages to provide the required signal gain. The low

pass M filter is carefully designed to provide the desired cut off at 3.58 megacycles, the subcarrier frequency, and maintain good phase response up to the cut off region. This is desirable to suppress moiré patterns and color contamination in the reproduced picture. The delay line is required to make the signal delay through the M channel the same as that by way of the Q channel so as to affect a proper time match in all signals at the matrix inputs. The aperture compensator, which is of the constant delay type, provides adjustable high frequency peaking that is very effective in enhancing the fine detail structure in the picture.

The chrominance channel includes a bandpass filter, low pass filters for the I and Q paths, I and Q signal demodulators, a delay line in the I signal path, plus video amplifier stages to provide the necessary signal gain, and signal phase splitters to provide two I signals 180 degrees out of phase and two Q signals 180 degrees out of phase. The band pass filter serves to restrict the signal to the subcarrier and its sidebands, which contain the chrominance information. This band limited signal then is fed to the I and Q demodulators. The demodulators are two synchronous detectors operating in quadrature. The subcarrier signal is processed in the color sync section to provide the two signals phased at 90 degrees with respect to each other for one of the signal inputs to each of the demodulators while the other input in each case is the chrominance signal itself. The I signal out of the demodulator passes through a low pass filter (1.5 mc.) to insure that no direct signal transmission through the I demodulator occurs, and then through a delay circuit. The delay is required to make the signal delay through the I channel the same as that by way of the Q channel so as to affect a proper time match in all signals at the matrix inputs. Finally the I signal is split by means of a phase splitting stage into two signals 180 degrees out of phase which are utilized in the matrix section. Similarly, the Q signal out of its demodulator passes through a low pass filter (500 kc) to suppress extraneous demodulation products. Because of this narrow band pass the total signal delay through the Q channel is inherently greater than through either the I or M unequalized channels. Thus it is used as the reference and delays are inserted in the I and M channels to insure time matching of the signal components at the matrix section. Finally, the Q signal is split by means of a phase splitting stage into two signals 180 degrees out of phase which are utilized in the matrix section.

The matrix section is a passive network of fixed resistors that establish the ratios by which signals from nine input terminals are added to subsequently appear at three output terminals. The input signals are M, -I, I, -Q and Q signals. The circuit functions to transform the M, I and Q signal components into red, green and blue (R, G and B) components which describe the identical color signal in terms of the color primaries of the system. The R, G and B signals are then amplified to a level suitable to operate the respective electron guns in the tricolor kinescope. D.C. restoration is accomplished at the grids of the kinescope.

Color Sync Section

The color synchronizing circuits serve to supply the continuous quadrature phased subcarrier signals to the color signal demodulators from the reference color sync burst present on the back porch of an FCC Standard signal. The signal, after amplification which emphasizes the sync and burst portion, is gated to permit only the burst information to pass. The gating action is controlled by a pulse obtained from a winding on the horizontal output

transformer. The burst of subcarrier signal is then used to excite a 3.58 mc. crystal which continues to oscillate or "ring" during the remainder of a line, thus providing a continuous 3.58 mc. sine wave. This wave is amplified, clipped and then split into quadrature phased signals in a special transformer.

Deflection and High Voltage Section

Scanning synchronization information is separated from the composite input signal after amplification and used in conventional fashion to synchronize the vertical and horizontal oscillators. External sync may be used if desired by switching to the external sync mode of operation and supplying the external sync signal to the proper input terminal at the rear of the chassis. The circuits for generating the scanning deflection fields are conventional, thus a functional description is not included here. However, the high voltage supply and convergence circuits are new and merit further consideration. The high voltage supply is a "kick-back" type that shares the horizontal output transformer with the horizontal deflection yoke. One rectifier circuit supplies the final accelerat-

ing voltage for the kinescope and a second voltage from a voltage divider that provides the d.c. component of the beam convergence signal. The kinescope high voltage is regulated by means of a shunt regulator tube. The action of this regulator tube is arranged to complement the load of the kinescope and thus maintain a constant load on the power supply. A second rectifier circuit supplies an adjustable output for the kinescope focus electrode.

The signal to accomplish dynamic convergence is generated by shaping the pulse trains taken from the vertical and horizontal output circuits, mixing them and then adding the mixed signal to the d.c. convergence voltage mentioned above. A similar voltage is added to the d.c. focus voltage to provide dynamic focus of the electron beams.

Low Voltage Supply

The plate and bias voltages are supplied by a conventional unregulated selenium rectifier power supply. If the 115 volt power source is not well behaved a line voltage stabilizer may be beneficial in maintaining freedom from line surge effects in the picture.

FIG. 5. Simplified block diagram of the RCA Color Television Monitor.

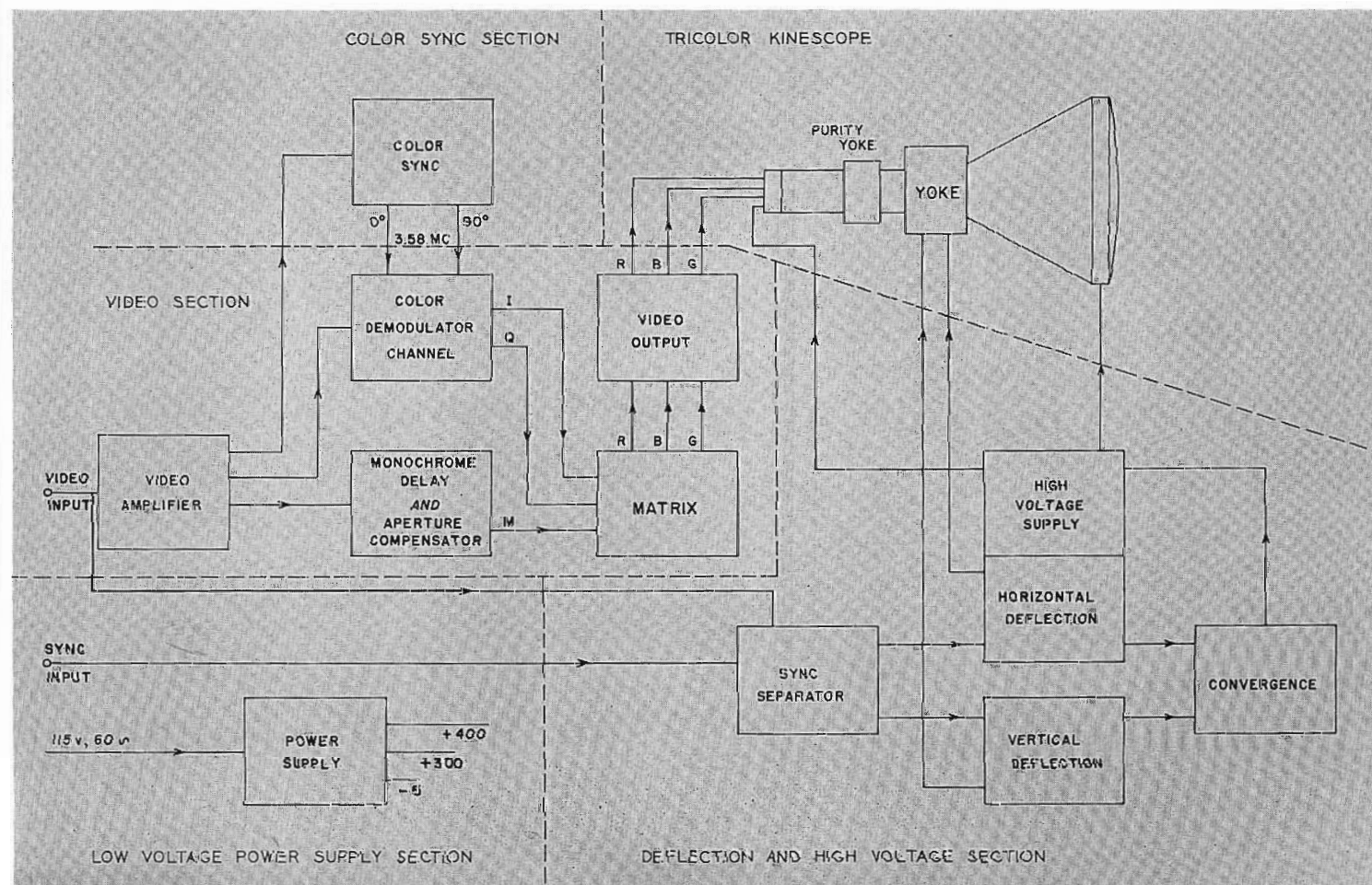

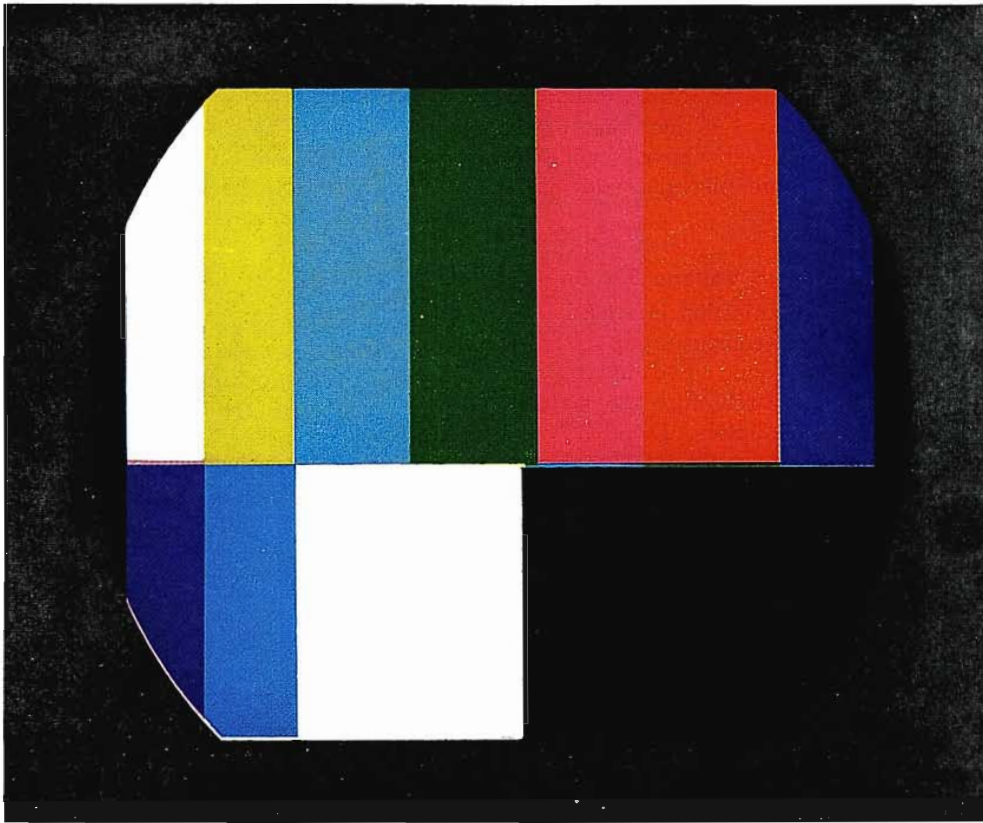

FIG. 1. Facsimile of pattern from Color Bar Generator showing colors as they appear on the Color Monitor. This pattern is electronically generated and is analogous to the Monoscope test pattern in Monochrome Television. It is used in accurate aligning of the Colorplexer. Colors in the top portion of the pattern are arranged from left to right in the order of their luminance—white, yellow, cyan, green, magenta, red and blue. The lower portion of the pattern contains, from left to right, special I and special Q signals, white and black.

Test Equipment FOR COLOR TELEVISION

By J. A. BAUER

Manager, Measurement and Requisition Engineering Group

In color television as in monochrome the subject of instrumentation encompasses the entire system operation. A greater number of Test units is required for RCA color system operation than for monochrome use. In many cases, these units are more complex and have been developed especially for color needs.

A list of Test Equipment desirable for use in color television is shown in Fig. 2. The Test Equipment listed in the chart falls into two general categories: (1) Test Equipment required by "Network Participating" Stations to re-broadcast network programs, and (2) Test Equipment required by stations who have the necessary equipment to originate their own color signal. The units required for the Network Participating Stations are listed with asterisks.

Color Bar Generator

The Color Bar Generator consists of a series of specially designed multivibrators with required amplifier, isolation and combining stages. It supplies a synthetic signal which permits exact alignment of the colorplexer. It provides a standard signal which is relatively free of the residual im-

perfections found in the output of even the best camera. The usefulness of its signal for color television is analogous to that of the monoscope in monochrome. The unit is pictured in Fig. 3.

The RCA Color Bar Generator has high stability, sharp rise time, and these other noteworthy features:

- (a) Color Bars occur in descending order of luminance.
- (b) Limiting action insures a constant level output of 1 volt P/P for all bar signals.
- (c) Bar signals are interlocked so that each bar is triggered by the preceding bar, thus eliminating drift.
- (d) The sharp rise time effectively reduces color fringing effects at the edges of the bars.
- (e) Special Q and I pulses are provided to simplify phase adjustment of the subcarrier signals.
- (f) A special white pulse is provided to facilitate white balance adjustments.

A four-position selector switch provides a choice of output signals:

Position 1—A full raster of color bars at 1 volt P/P level.

Position 2—A full raster of special Q and I pulses at 1 volt P/P from each of the red, blue and green output jacks producing white.

Position 3—A half raster of each signal in Position 1 and Position 2. Colors are across the top half; I, Q and white pulses across the bottom. See Fig. 1.

Position 4—Same as Position 3 except that the red, blue, and green outputs are reduced to 75% of full level. This is provided for special purpose testing of the transmitter.

The input signals required by the Color Bar Generator are the Composite Blanking and Vertical Drive both at the standard four volts P/P levels.

Color Signal Analyzer

The Color Signal Analyzer is a device used for measuring phase at the subcarrier frequency. While it contains features that make possible a complete analysis of a color bar signal to check adjustment of colorplexer and other equipment used by

stations originating their own color programs, it is also an essential tool for making phase intermodulation measurements by "Network Participating" stations. The unit is used along with the Linearity Checker in performance of these phase intermodulation checks.

Two input signals are required for operation of the Color Signal Analyzer: (1) the composite color signal to be measured, and (2) a continuous reference subcarrier signal. For making phase intermodulation measurements, both these signals are provided by the Linearity Checker.

The unit also provides a means of determining the phase relation of chrominance signals with respect to the burst or to each other. This is accomplished by using the Uncalibrated Phase Shifter for making a zero null adjustment associated with one signal. This establishes an initial reference. The Delay Standard or Calibrated Phase Shifter is then adjusted for another zero null adjustment which is associated with a second signal. The phase difference between the two chrominance signals or subcarrier and chrominance signal may then be read directly. Subcarrier phase errors may be read with an accuracy of plus or minus 0.5 degrees.

The Delay Standard contains only passive circuits. It is equipped with switches to insert 90°, 50°, 30°, 20°, 10°, and 5° in any combination desired to a possible total of 205° delay. These delay sections are composed of 73 ohm RG-59/U cable. Compensating attenuators maintain constant attenuation to 1%. A rotary switch per-

ITEM	EQUIPMENT TITLE	PURPOSE
1.	COLOR BAR GENERATOR MI-34001C	PROVIDES STANDARD COLOR SIGNAL FOR ALIGNING COLORPLEXERS AND MONITORS
*2.	COLOR SIGNAL ANALYZER MI-34016	PROVIDES MEANS FOR MEASURING SUBCARRIER PHASE IN COLORPLEXERS, ETC.
*3.	LINEARITY CHECKER MI-34017	PROVIDES MEANS FOR MEASURING DIFFERENTIAL GAIN AND PHASE INTERMODULATION
*4.	CONVERGENCE DOT GENERATOR	FOR ADJUSTING CONVERGENCE OF BEAMS IN TRI-COLOR KINESCOPE
*5.	COLOR MONITOR ANALYZER MI-34022	DELIVERS PHASE CONTROLLED SIGNAL FOR ALIGNING RECEIVERS AND MONITOR SYNC. DETECTORS
*6.	BURST CONTROLLED OSC. MI-34023	PROVIDES REFERENCE C.W. SUBCARRIER FOR REMOTE OPERATION OF COLOR SIGNAL ANALYZER
7.	COLOR COMPARATOR MI-34027	TO STANDARDIZE TRI-COLOR MONITOR COLOR TEMPERATURES
8.	ENVELOPE DELAY SWEEP MI-34031	ENABLES MEASUREMENT OF TIME DELAY FOR VIDEO FREQUENCIES ABOVE 500 KC
*9.	C.R.O. TO-524-D MI-26500	GENERAL UTILITY
10.	VIDEO SW. GEN'R WA-21B MI-30021B	GENERAL UTILITY
*11.	TV SIDEBAND RESPONSE ANALYZER BW-5-A MI-34000	PROVIDES MEANS FOR PROPER ALIGNMENT OF TRANSMITTER OUTPUT CIRCUITS
*12.	SQUARE WAVE GENERATOR	GENERAL UTILITY
13.	SUBCARRIER FREQ. MONITOR	INDICATES FREQUENCY 3.579545 MC

FIG. 2. List of Test Equipment recommended for Color Television use. Items marked with asterisk (*) are units required for Network Participating stations. See "How to Plan for Color", Page 20.

mits shifting from minus 5° to plus 5° in 1° steps. This is also made up of RG-59/U cable lengths. Suitable terminating and isolating circuits are provided to maintain these delays constant.

The unit, pictured in Fig. 4, has a self-contained power supply and is packaged on three chassis totaling 19 inches wide by 17½ inches high. They may be housed together in a single table-mounted cabinet.

FIG. 3. The Color Bar Generator provides a standard signal, relatively free of residual imperfections. Its signal is analogous to the monoscope signal in monochrome television.

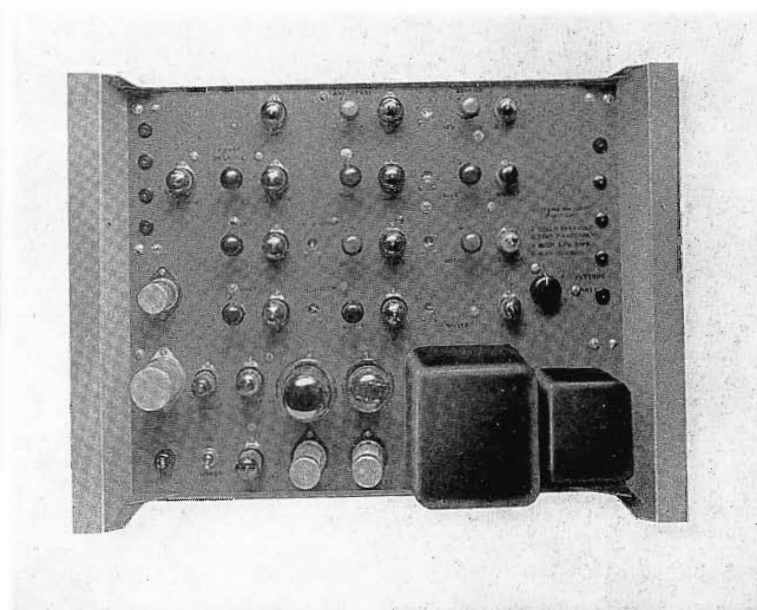
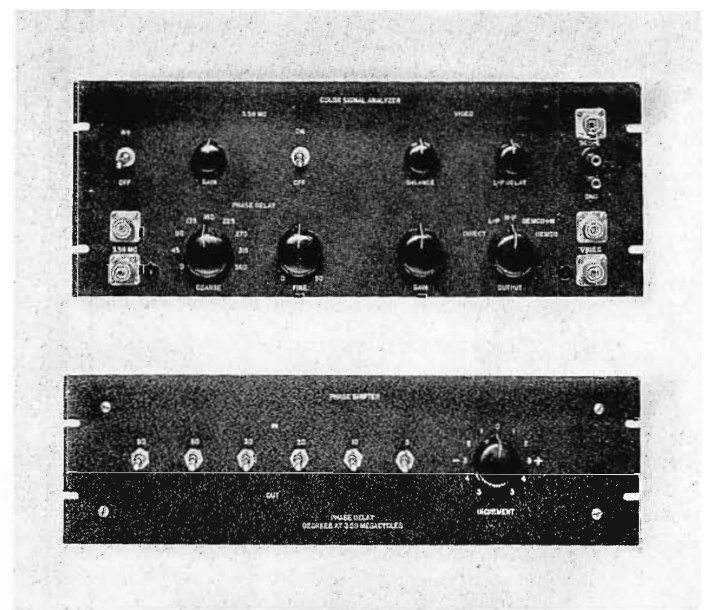

FIG. 4. The Color Signal Analyzer is used for measuring phase of subcarrier frequency. Along with Linearity Checker it is used for phase intermodulation checks.



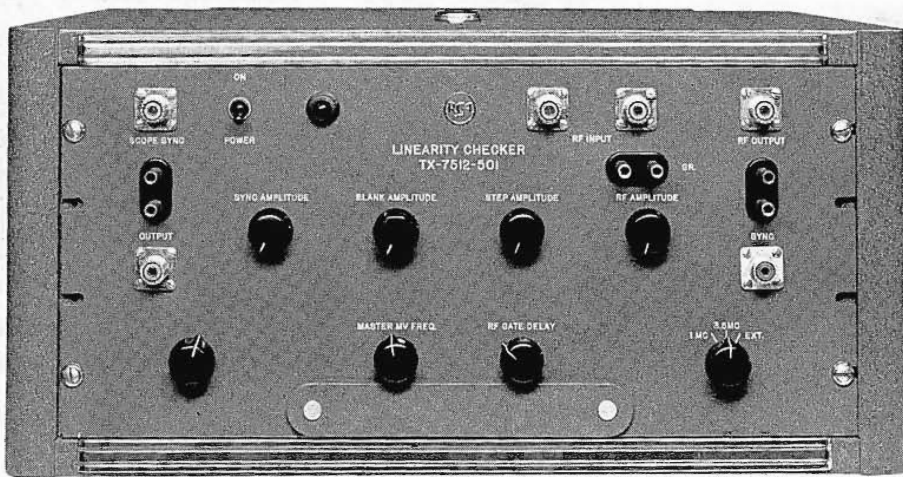

FIG. 5. The Linearity Checker is used to correct for the transfer characteristic attributable to grid modulation in the transmitter and also to correct the transfer characteristic or gamma of the camera pickup tube.

Linearity Checker

The Linearity Checker generates a test signal for measuring amplitude linearity and phase intermodulation (variation of subcarrier phase shift from black to white level). It is used in correcting for the transfer characteristic attributable to grid modulation in the transmitter and also for correcting the transfer characteristic or gamma of the camera pickup tube to complement that of the kinescope. After appropriate transmitter and studio corrections have been made, the unit is used throughout the system to determine and adequately maintain linearity and phase intermodulation.

The test signal consists of a ten-step staircase waveform at horizontal line frequency with a constant-amplitude subcarrier superimposed on each step. Horizontal sync and blanking pulses are produced in the unit so that the test signal may be passed through stabilizing amplifiers and other devices with "back porch" clamps. The Linearity Checker needs no input other than 115 volt, 60-cycle power, yet it can be "locked in" to some external horizontal drive, if desired.

The signal from the Linearity Checker is passed through the circuit under test and through a "Hi-lo" filter to an oscilloscope. The "Hi-lo" filter is supplied with the unit. When in the hi-pass position, the

steps are removed from the signal leaving only the subcarrier. Any variation in the subcarrier envelope indicates non-linearity—the variation in the amplitude of the subcarrier being a more sensitive indication of non-linearity than the usual step-signal technique.

The Linearity Checker is pictured in Fig. 5. It is available in a self-contained case or for rack mounting.

Convergence Dot Generator and Color Monitor Analyzer

These two units of Test Equipment are required for making daily tests on Tri-Color Monitors. They may also be used for adjustment of a station's color receivers.

The Convergence Dot Generator is used to adjust the convergence of the three scanning beams in the Tri-Color Kinescope. The output of the Convergence Dot Generator is a composite monochrome video signal which produces a pattern of white dots on a black background on the face of the picture tube. If the convergence of the electron beams is perfectly adjusted, all the dots appear to be of uniform size and whiteness without any color fringes in any part of the pattern. If the convergence is improperly adjusted in the same area of the pattern, color fringes will appear in the dots. This equipment may also be adjusted to provide the standard RTMA grating signal.

Broadcasters who already have the WA-3A Grating Generator will find that this unit performs many of the functions of the Convergence Dot Generator. A simple modification will convert the WA-3A to produce dots; thus both dots and bars will be available.

The Convergence Dot Generator has a self-contained power supply and is designed for either table-top or rack mounting. A table model cabinet is provided. When rack mounted, the equipment occupies $8\frac{3}{4}$ inches of rack space.

The Color Monitor Analyzer is an electronic signal generator which produces a test signal used for adjusting the decoding system of a monitor or receiver. (The decoding system is the heart of the monitor or receiver since it "unscrambles" the composite color signal and produces the red, green and blue video signals.)

The output signal of this unit contains five subcarrier bursts, preset at specific values of phase angle. Test points are provided in the monitor or receiver for observing the video waveform with an oscilloscope. When the decoder is properly adjusted, one of the bursts will disappear at each of the test points. If the burst does not disappear, the decoder can be adjusted until it does. The last four bursts are omitted from alternate horizontal periods to provide a zero reference line. The output signal contains no vertical synchronizing information since the test procedure does not require the production of a scanning raster.

The equipment is entirely self-contained and is packaged in portable form so that it may be useful in servicing color receivers as well as color monitors.

Burst Controlled Oscillator

The Burst Controlled Oscillator is used in the special case where phase intermodulation measurements are made over a studio-to-transmitter link or in any other circumstances where the test signal source must be at a distance from the point of measurement. The unit is approximately the same size as the Linearity Checker, and it provides a continuous subcarrier signal output. This output is locked in frequency and phase to the color synchronizing bursts which are part of the incoming video signal being measured. This signal is a required input to the Color Signal Analyzer.

It is possible to delete this item from the equipment list if studio and transmitter are at the same location and if testing procedures are not to be made at a point remotely located from subcarrier signal sources.

Color Comparator

The Color Comparator is used to adjust studio color monitors to the same color temperature. It serves to make adjustments independent of an individual observer. This unit is also valuable in obtaining pictures with similar appearance at both ends of the video line or when monitors are located side by side.

Envelope Delay Sweep

The Envelope Delay Sweep is a necessary instrument for adjusting the transmitter and obtaining "proof of performance" of its phase vs. frequency characteristic, particularly at the higher frequency end of the video spectrum. This measurement is accomplished by generating a pair of signals with constant frequency separation. As the pair of frequencies is swept through

the video spectrum, the phase of each is compared in a phase comparator circuit. The output of the comparator indicates whenever the phase of one signal is shifted with respect to the other. The resultant trace on an oscilloscope therefore indicates the slope or first derivative of the phase/frequency curve. This method effectively magnifies any departure from linearity in this curve and provides an easy means of making the necessary equalization adjustments.

Square Wave Generator

The Square Wave Generator is a self-contained unit capable of producing square waves at 60 cycles and 100 kc. It is used in adjusting the Low Frequency Phase Correction Network. In performing the test, the output of the Generator is applied to

the input terminals of the phase correcting networks. By observing the output from the modified Demodulator with an oscilloscope, it is possible to adjust the Low Frequency Phase Correction Network for the best square wave.

TO-524-D Oscilloscope

This Oscilloscope has a 10-megacycle bandwidth and excellent transient response required in making the accurate waveform analysis necessary in color television. Tests at both the studio and transmitter locations require this unit. A scopemobile greatly increases its flexibility, and it is recommended as an accessory test item.

The balance of the equipment listed in Fig. 2 will be recognized as standard and is readily available. Still other equipments are of a supplementary nature.

FIG. 6. Test Equipment arranged for Colorplexer alignment in order to produce a composite color television signal.

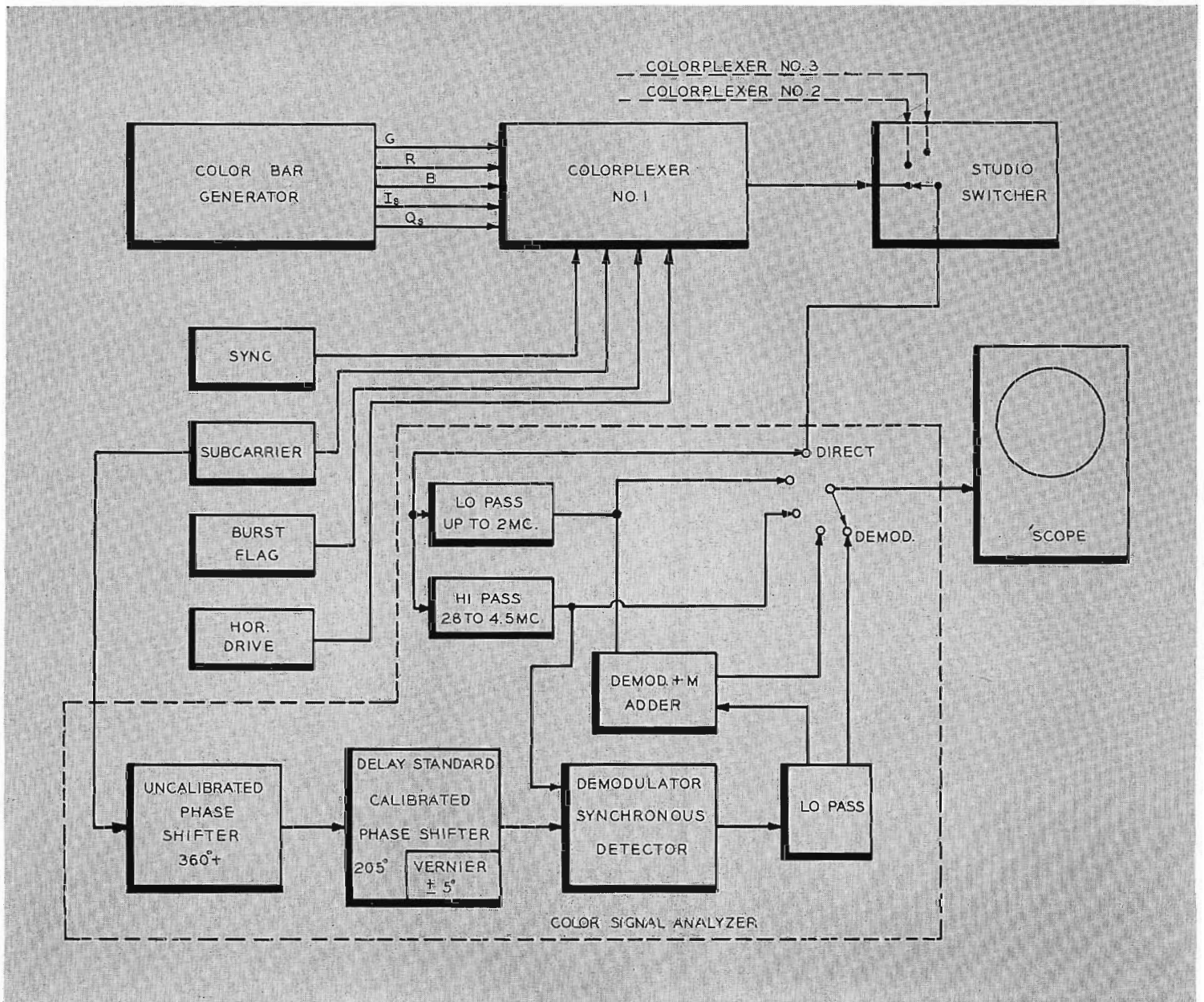

FOR ASSISTANCE IN PLANNING YOUR *Color* NEEDS...

RCA Field Representatives located in the District Offices listed here will offer further assistance and information concerning your particular Color Television Equipment needs. You'll find them always ready and willing to help you plan your initial installation keeping in mind the requirements for future expansion. For all your television equipment needs—for monochrome as well as color, contact your RCA District Representative.

Atlanta 3, Ga.

522-533 Forsyth Bldg., Walnut 5946

Boston 16, Mass.

200 Berkeley St., Hubbard 2-1700

Camden 2, N. J.

Front & Cooper Sts., Woodlawn 3-8000

Chicago 11, Ill.

666 N. Lake Shore Drive, Delaware 7-0700

Cleveland 15, Ohio

718 Keith Bldg., Cherry 1-3450

Dallas 1, Texas

1907-11 McKinney Ave., Riverside 1371-2-3

Dayton 2, Ohio

120 West Second St., Hemlock 5585

Hollywood 28, Cal.

1560 N. Vine St., Hollywood 9-2154

Kansas City 6, Mo.

1006 Grand Avenue, Harrison 6480-1-2

New York 20, N. Y.

36 W. 49th St., Circle 6-4030

San Francisco 3, Cal.

1355 Market St., Hemlock 1-8300

Seattle 4, Wash.

2250 First Avenue, South, Main 8350

Washington 6, D. C.

1625 K St., N. W., District 1260



BROADCAST EQUIPMENT SECTION
RADIO CORPORATION OF AMERICA
ENGINEERING PRODUCTS DIVISION, CAMDEN, N. J.

Put your UHF signal where the population is

Use an RCA "contour-engineered" UHF Pylon Antenna

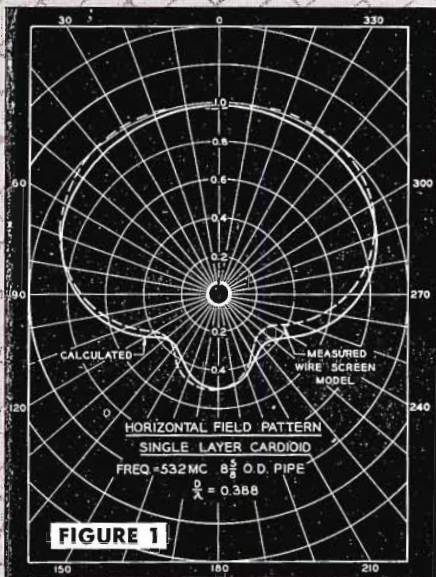

FIGURE 1

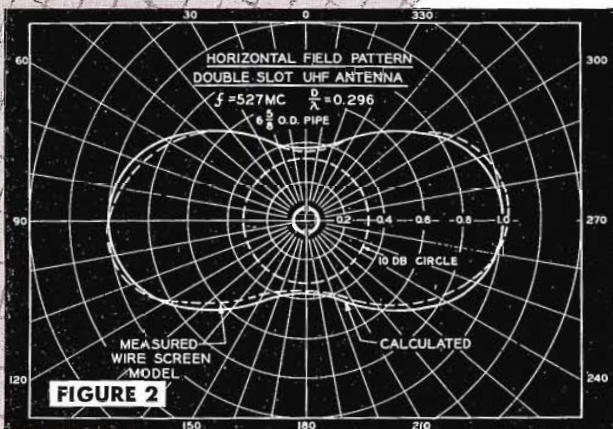

FIGURE 2

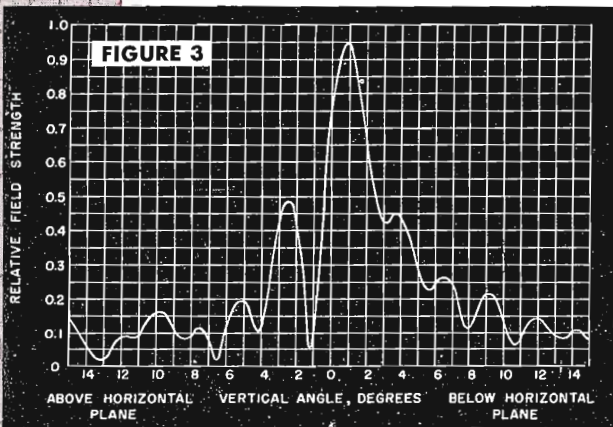

FIGURE 3

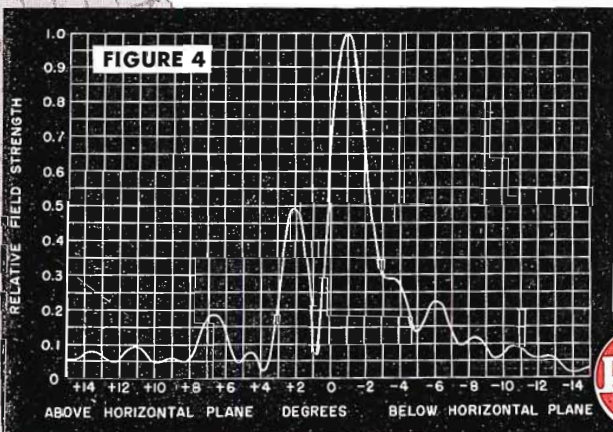
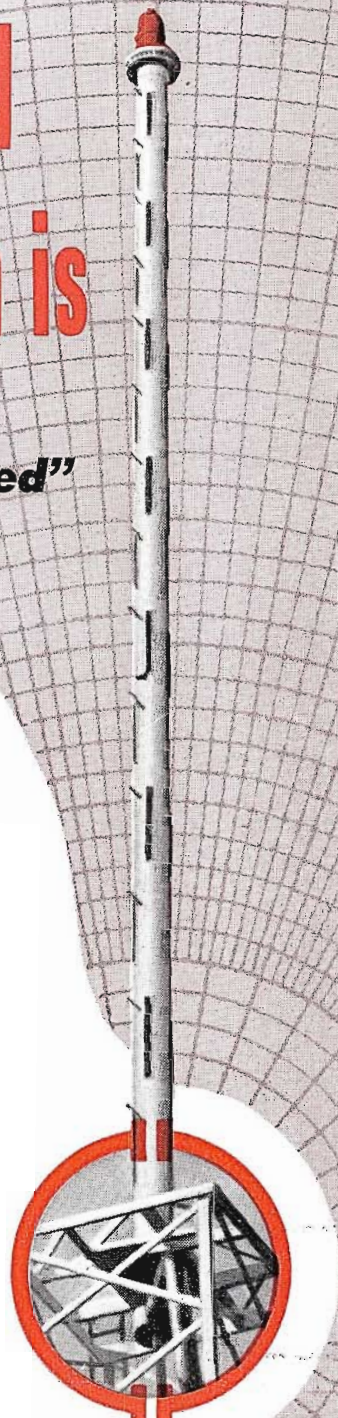

FIGURE 4

- For "single-direction" coverage, RCA has UHF Pylons that produce a horizontal field pattern shaped like a Cardioid (see Fig. 1).
- For "elongated" coverage, RCA has UHF Pylons that produce a horizontal field pattern shaped like a peanut (see Fig. 2).
- For "circular" coverage, RCA has a wide selection of UHF Pylons that produce equal signals in ALL directions.
- For better overall coverage, RCA UHF Pylons have built-in "Beam Tilt" that minimizes power loss in vertical radiation.
- For better "close-in" coverage, RCA UHF Pylons are equipped with a new, advanced type null fill-in system (used in conjunction with beam tilting). See Figs. 3 and 4.
- The gain that's published is the gain you get. RCA UHF Pylons include no tuning compromises that would result in loss of gain. RCA UHF Pylons can be furnished with gains in the order of 3, 6, 9, 12, 21, 24, and 27!
- RCA has all UHF antenna accessories: towers, mitered elbows, line transformers, spring hangers, dummy loads, wattmeters, frequency and modulator monitors, filterplexers, and transmission line (measured performance—VSWR—is better than 1.05 to 1.0). You can get everything from ONE responsible source—RCA!



RCA Adjustable Beam High Gain UHF Pylon —installed

An antenna system can make or break a TV station. Make sure yours is right. Your RCA Broadcast Sales Representative can help you plan.



RADIO CORPORATION of AMERICA
ENGINEERING PRODUCTS DEPARTMENT
CAMDEN, N. J.

“Color will make television more exciting, more dramatic and more enjoyable. It will give added sales power to commercial messages. It will attract advertisers who now do not use the medium because their particular products cannot be fully appreciated in black and white.”

Brig. Gen. David Sarnoff

Address before NARTB
Los Angeles, April 29, 1953